

Part IV

ECHONET Lite Gateway Specifications

The specifications published by the ECHONET Consortium are established without regard to industrial property rights (e.g., patent and utility model rights). In no event will the ECHONET Consortium be responsible for industrial property rights to the contents of its specifications.

In no event will the publisher of this specification be liable for any damages arising out of use of this specification.

The original language of the ECHONET Lite Specifications is Japanese. This English version is a translation of the Japanese version; in case of any queries about the English version, refer to the Japanese version.

Contents

Chapter 1	Outline of ECHONET Lite Gateway Specification	1-1
1.1	CONCEPT	1-1
1.2	CONCEPT OF ECHONET LITE CONNECTIONS WITH EXTERNAL SYSTEMS	1-1
1.3	ECHONET LITE GATEWAY TYPES	1-1
1.4	ECHONET LITE GATEWAYS COVERED.....	1-2
Part 1.	Specifications for ECHONET Lite-UPnP Gateways.....	Part1-1
Chapter 1	Overview	Part1-1-1
1.1	CONCEPT	Part1-1-1
1.1.1	Background of the development.....	Part1-1-1
1.1.2	Purpose of the Specifications for ECHONET Lite-UPnP Gateways	Part1-1-1
1.2	RELATIONSHIP BETWEEN THE ECHONET LITE DCP/ECHONET LITE-UPnP GATEWAY SOFTWARE AND OTHER COMMUNICATION LAYERS	Part1-1-1
1.3	SYSTEM STRUCTURE AND THE RELATIONSHIP BETWEEN THE ECHONET LITE-UPnP GATEWAY AND OTHER SYSTEM COMPONENTS	Part1-1-2
1.3.1	Design principles	Part1-1-2
1.3.2	System structure	Part1-1-2
1.4	SUBJECT MATTERS AND SCOPE OF THE SPECIFICATIONS.....	Part1-1-3
1.4.1	Subject Matters of the Specifications	Part1-1-4
1.4.2	Scope of the ECHONET Lite Specifications	Part1-1-5
Chapter 2	Definitions of Terms.....	Part1-2-1
Chapter 3	UPnP Device-based Method	Part1-3-1
3.1	CONCEPT	Part1-3-1
3.2	CLASSIFICATION OF ECHONET LITE PROPERTIES	Part1-3-2
3.2.1	ECHONET property type-based classification.....	Part1-3-3
3.2.2	Data type-based classification	Part1-3-8
3.3	NAMING RULES	Part1-3-11
3.3.1	Naming rules necessary for XML Device Descriptions	Part1-3-11
3.3.2	Naming rules based on ECHONET property type-based classification.....	Part1-3-11
3.3.3	Definition of the dataType based on data type-based classification.....	Part1-3-12

3.3.4	Argument naming rules	Part1-3-13
3.4	SUMMARY OF THE RELATIONSHIPS BETWEEN PROPERTY TYPES, DATA TYPES, OBJECTS, ACTION PREFIXES AND DATATYPES	Part1-3-13
Chapter 4	Processing for ECHONET Lite-UPnP Gateways for the UPnP Device-based Method	Part1-4-1
4.1	PLUG AND PLAY PROCESSING	Part1-4-1
4.1.1	Plug and play processing to be performed when an ECHONET Lite-UPnP gateway connects to a network.....	Part1-4-1
4.1.2	Plug and play processing to be performed when an ECHONET Lite device connects to a network.....	Part1-4-2
4.2	CONTROL OF ECHONET LITE DEVICES FROM UPNP CONTROL POINTS.....	Part1-4-3
4.2.1	Control of ECHONET Lite devices.....	Part1-4-3
4.2.2	Referencing the statuses of ECHONET Lite devices	Part1-4-5
4.3	NOTIFYING THE STATUSES OF ECHONET LITE DEVICES TO UPNP CONTROL POINTS	Part1-4-7
Chapter 5	Device Template.....	Part1-5-1
5.1	DEFINITION OF DEVICE	Part1-5-1
5.1.1	Device Type	Part1-5-1
5.1.2	Device requirements	Part1-5-1
5.2	XML DEVICE DESCRIPTIONS	Part1-5-2
5.3	EXAMPLE XML DEVICE DESCRIPTION (AIR CONDITIONER)	Part1-5-3
Chapter 6	Service Template	Part1-6-1
6.1	DEFINITION OF SERVICE MODEL	Part1-6-1
6.1.1	Service Type	Part1-6-1
6.1.2	Service Type requirements	Part1-6-1
6.1.3	Action	Part1-6-2
6.2	XML SERVICE DESCRIPTIONS	Part1-6-4
6.3	EXAMPLE XML SERVICE DESCRIPTION (AIR CONDITIONER)	Part1-6-6
Chapter 7	ECHONET Object-based Method.....	Part1-7-1
7.1	CONCEPT.....	Part1-7-1
Chapter 8	Processing for ECHONET Lite-UPnP Gateways for the ECHONET Object-based Method	Part1-8-1

8.1	PLUG AND PLAY PROCESSING	Part1-8-1
8.1.1	Processing to be performed when an ECHONET Lite-UPnP gateway connects to a network	Part1-8-1
8.1.2	Processing to be performed when a UPnP device connects to a network	Part1-8-2
8.2	CONTROL OF UPnP DEVICES FROM ECHONET OBJECTS.....	Part1-8-3
8.2.1	Control of UPnP Devices.....	Part1-8-3
8.2.2	Referencing the statuses of UPnP devices	Part1-8-4

Chapter 1 Outline of ECHONET Lite Gateway Specification

1.1 Concept

The ECHONET Lite principal specifications provide 1) communication protocol specifications for devices connected to equipment systems and 2) intra-device interface and processing specifications for homes, small buildings, and stores. In such environments the equipment system is rarely operated independently (i.e., without connections to other systems). Instead, it is usually connected both to an external system(s) and to an AVCC system within the building. In the ECHONET Lite Specification, devices which are located between the ECHONET Lite system and an external system and which supervise the linked action relay are called ECHONET Lite Gateways.

1.2 Concept of ECHONET Lite Connections with External Systems

The basic concept of connections with external systems in ECHONET Lite is as follows.

- (1) Access to an ECHONET Lite Device from outside the building shall be allowed only after a security check by the ECHONET Lite Gateway.
- (2) The ECHONET Lite communication protocol does not specify a code for identification of the ECHONET Lite Domain. To identify multiple ECHONET Lite Domains from an external system, each application software program shall define its own identifier for each domain.

1.3 ECHONET Lite Gateway Types

ECHONET Lite Gateways are classified into the following three types based on usage. This classification is based on the information security level of the ECHONET Lite Domain to be secured. This standard does not specify gateway specifications for each type; instead, only examples are presented for reference.

- (1) External service vendor gateway type
- (2) Outdoor user gateway type
- (3) In-house system gateway type

- (1) External service vendor gateway type

The external service vendor gateway is a gateway for a system to be used by external service vendors connected to in-home ECHONET Lite Domains. The home dweller shall have control over information within the in-home ECHONET Lite Domain. Public disclosure of information shall be limited to the scope specified by the dweller.

(2) Outdoor user gateway type

The outdoor user gateway is a gateway for external systems connected to in-home ECHONET Lite Domains. However, unlike the “External service vendor gateway”, the user has control over information contained in the in-home ECHONET Lite Domain. That is, this gateway is tele-controlled based on the assumption that outside users are accessing the system.

(3) In-house system gateway type

The in-home gateway is a gateway for an ECHONET Lite Domain connected to another system in the same house. Here, the user of the other system is presumed to be the same as the person with control over information in the ECHONET Lite Domain. One example might be gateways for connection with AVCC system networks.

1.4 ECHONET Lite Gateways Covered

This ECHONET Lite Specification defines the specifications for ECHONET Lite gateways that fall under the following category:

Part 1: ECHONET Lite-UPnP Gateways

Part 1. Specifications for ECHONET Lite-UPnP Gateways

This part defines the specifications for those ECHONET Lite gateways which are categorized as premises system gateway type ECHONET Lite-UPnP gateways and connect to UPnP, which is a communication protocol for audiovisual devices.

Chapter 1 Overview

1.1 Concept

1.1.1 Background of the development

With the trend in recent years toward networks that can connect to information devices and audiovisual devices, UPnP™ has been gaining attention as a suitable communication protocol and efforts have been progressing to apply UPnP™ in products. In future, because household-use ECHONET Lite devices are likely to be integrated with information and/or audiovisual devices or as part of systems that include information and/or audiovisual devices, coexistence with UPnP devices is required.

1.1.2 Purpose of the Specifications for ECHONET Lite-UPnP Gateways

To allow ECHONET Lite devices and audiovisual devices in a home to operate in coordination with each other, a gateway function to interconnect the ECHONET Lite protocol with the UPnP protocol for audiovisual devices is required. These Specifications for ECHONET Lite-UPnP Gateways were developed to provide UPnP-specific gateway function specifications to allow realistic interconnections across the boundary between ECHONET Lite device and audiovisual device development vendors.

1.2 Relationship between the ECHONET Lite DCP/ECHONET Lite-UPnP Gateway Software and Other Communication Layers

This ECHONET Lite Specification defines the requirements for the ECHONET Lite DCP (Device Control Protocol), which overlies the UPnP Device Architecture. The ECHONET Lite DCP defines the UPnP commands for ECHONET Lite.

The ECHONET Lite-UPnP gateway software overlies the ECHONET Lite communication processing section and ECHONET Lite DCP. This ECHONET Lite Specification (Part 9) defines the specifications for the ECHONET Lite-UPnP gateway software. **Fig. 1.1** shows the relationship between the ECHONET Lite DCP/ECHONET Lite-UPnP gateway software (shaded parts) and other communication layers.

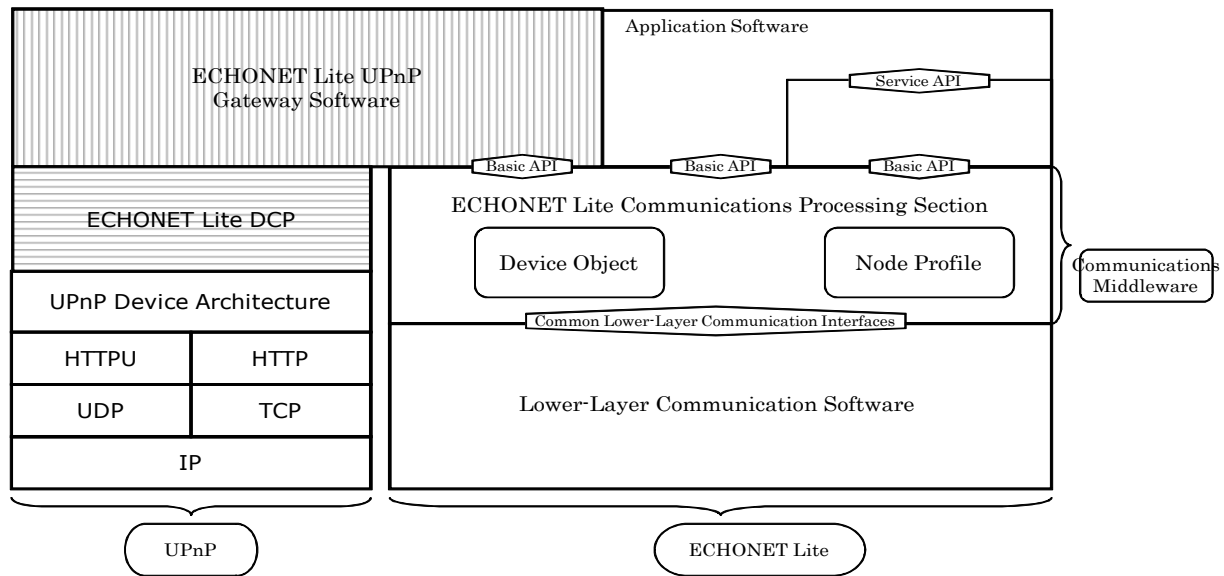

Fig. 1.1 Relationship between the ECHONET Lite-UPnP Gateway Software and Other Communication Layers

1.3 System Structure and the Relationship between the ECHONET Lite-UPnP Gateway and Other System Components

1.3.1 Design principles

The common specifications for the ECHONET Lite-UPnP gateway software were developed based on the following design principles:

- The existing ECHONET Lite Specification (excluding Part 9) should not be altered.
- The existing UPnP specifications (UPnP Device Architecture) should not be altered.
- It should be possible to accommodate existing ECHONET Lite devices without any alteration.
- It should be possible, when new ECHONET Lite device object specifications are added, to develop corresponding UPnP specifications easily.

Where no UPnP specification is clearly defined in this chapter, the UPnP Device Architecture specifications (including error codes) shall be followed.

1.3.2 System structure

The system structure is as shown in **Fig. 1.2**. This version of the Specifications for ECHONET Lite-UPnP Gateways defines the specifications for two methods to achieve ECHONET Lite-UPnP gateway-based communications. The first is a method in which device objects of ECHONET Lite devices are controlled from application software programs (UPnP control points) implemented in audiovisual devices via an ECHONET Lite-UPnP gateway (hereinafter referred to as the “UPnP Device-based Method”), and the

second is a method in which functions of audiovisual devices (UPnP devices) are controlled from ECHONET Lite devices via an ECHONET Lite-UPnP gateway (hereinafter referred to as the “ECHONET Object-based Method”).

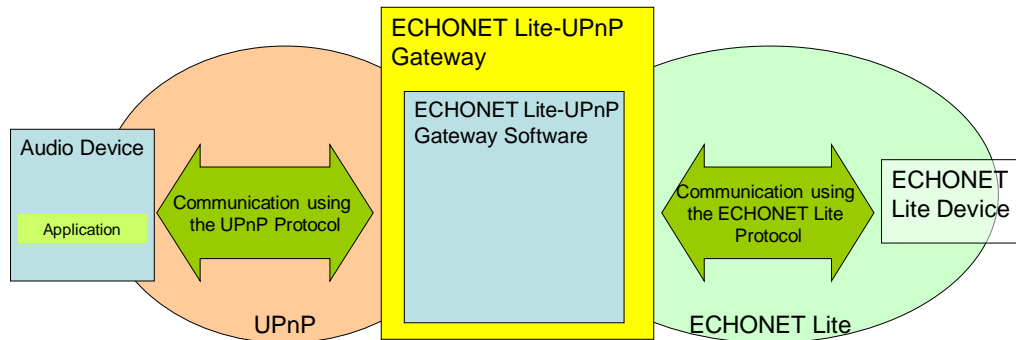

Fig. 1.2 Structure of an ECHONET Lite-UPnP Gateway System

1.3.2.1 UPnP Device-based Method

In the UPnP Device-based Method, functions to control ECHONET Lite nodes and UPnP device functions are implemented in a gateway to publish functions of ECHONET Lite devices to the UPnP side as UPnP devices. In this method, the gateway generates virtual UPnP devices that correspond to the target ECHONET device objects and provides functions to UPnP control points (application software) implemented on the audiovisual device side. ECHONET Lite-UPnP gateways shall be implemented with objects in accordance with Part 2, Section 9.1 so that they can operate as ECHONET Lite nodes. Implementation of the UPnP Device-based Method in ECHONET Lite-UPnP gateways is compulsory.

1.3.2.2 ECHONET Object-based Method

In the ECHONET Object-based Method, functions to allow control from other ECHONET Lite nodes and UPnP control point functions are implemented in a gateway to publish functions of audiovisual devices to the ECHONET Lite side as ECHONET objects. In this method, the gateway generates ECHONET objects corresponding to the target UPnP devices and provides functions to ECHONET Lite nodes (application software) that provide control in the ECHONET Lite system. Implementation of the ECHONET Object-based Method in ECHONET Lite-UPnP gateways is optional.

1.4 Subject Matters and Scope of the Specifications

1.4.1 Subject Matters of the Specifications

The Specifications for ECHONET Lite-UPnP Gateways specify techniques to allow ECHONET Lite protocol side devices interconnected with UPnP protocol side devices to identify and control the UPnP protocol side devices and vice versa.

In principle, ECHONET Lite-UPnP gateways developed by any vendor must be capable of achieving interconnection with ECHONET Lite devices and with UPnP devices developed based on these specifications. The Specifications for ECHONET Lite-UPnP Gateways provide the minimum requirements and operation sequences to achieve this.

(1) Common specifications for plug & play processing

The device/service search and detection procedures to be performed when a device enters or exits a network for the ECHONET Lite protocol differ from those for the UPnP protocol. The Specifications for ECHONET Lite-UPnP Gateways are common specifications to allow plug & play processing for ECHONET Lite devices and UPnP devices to be performed taking into account the differences between the ECHONET Lite and UPnP protocols through the use of an ECHONET Lite-UPnP gateway.

Specifically, the Specifications for ECHONET Lite-UPnP Gateways include the specifications for functions to voluntarily notify, upon detection of a device entering a network, the presence of the device to other networks and the specifications for PnP processing functions to respond to incoming device search packets from control terminals in other networks.

(2) Common specifications for the mapping of ECHONET device objects to UPnP DCP

The common specifications for the mapping of ECHONET device objects to UPnP DCP are specifications that apply to the UPnP Device-based Method. These are specifications for the DCP for UPnP corresponding to ECHONET device objects (properties), which are intended to allow ECHONET Lite devices to be controlled from UPnP networks as UPnP devices. In the ECHONET Lite Specification, many ECHONET device objects have already been defined, and new ones are likely to be added in the future. Therefore, the common specifications for the mapping of ECHONET device objects to UPnP DCP define the rules for formulaic mappings of ECHONET device object definitions to UPnP DCP definitions. By defining such mapping rules, it becomes possible to express existing device objects using a formulaic description method.

Specifically, control of ECHONET Lite devices from UPnP control points is achieved by treating ECHONET Lite devices as virtual UPnP devices at an ECHONET Lite-UPnP gateway. To treat ECHONET Lite devices as virtual UPnP devices, device/service description documents for ECHONET Lite devices are required. The common specifications for the mapping of ECHONET device objects to UPnP DCP define the mapping rules to generate, in a formulaic way, XML descriptions of device/service descriptions of UPnP from ECHONET property codes and service codes and the selection of the ECHONET Lite device data necessary to generate these. The mapping rules were

developed after organizing the classification of existing ECHONET device objects necessary for such development. In addition, the specifications for various processing functions to convert device control commands sent from actual UPnP control points into ECHONET Lite commands at an ECHONET Lite-UPnP gateway and send them to the relevant devices are provided.

(3) Common specifications for ECHONET device objects that pass data to UPnP devices
 The common specifications for ECHONET device objects that pass data to UPnP devices are specifications that apply to the ECHONET Object-based Method. The common specifications define the requirements for the objects necessary to publish functions of audiovisual devices to the ECHONET Lite side as ECHONET device objects. Provision of DCP requirements for the UPnP device side is outside the scope of the ECHONET Lite Specification.

1.4.2 Scope of the ECHONET Lite Specifications

The scope of the Specifications for ECHONET Lite-UPnP Gateways is as shown in **Fig. 1.3**. The core of this version of the Specifications for ECHONET Lite-UPnP Gateways is the rules (mapping rules) for generating the data necessary to publish ECHONET device objects (as defined in the current ECHONET Lite Specification) in UPnP side networks as UPnP devices. The components of the Specifications for ECHONET Lite-UPnP Gateways are as follows:

- Mapping rules (Chapter 3 and succeeding chapters)
- Additional descriptions necessary for device objects and examples of application to current ECHONET device objects (Appendix 2)
- Operation sequences for each method

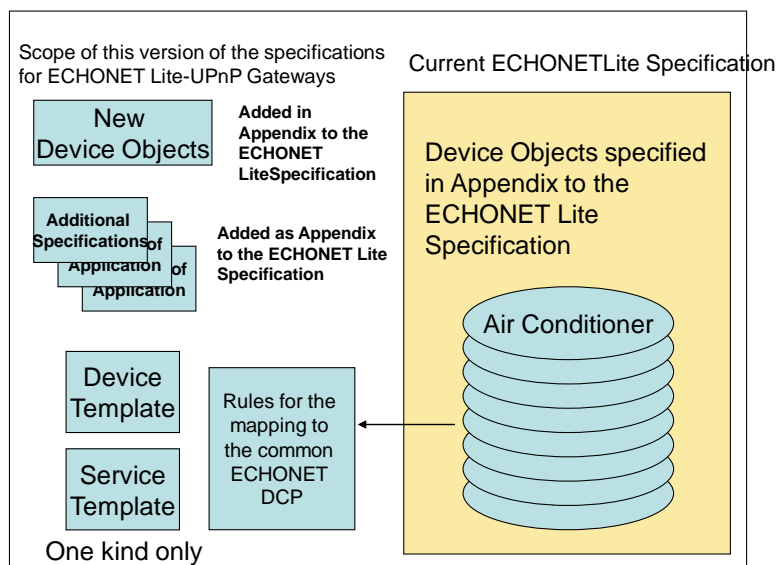

Fig. 1.3 Scope of the Specifications

Chapter 2 Definitions of Terms

- Appendix

An appendix that provides detailed specifications for the properties of the ECHONET device objects.

- Appendix 2

An appendix that provides specifications for the properties of the ECHONET device objects as UPnP devices.

- Appliance name

The name of an ECHONET device object published in a UPnP network.

- ECHONET Object-based Method

A method to publish functions of audiovisual devices to the ECHONET Lite side using an ECHONET Lite-UPnP gateway.

- Virtual UPnP device

An ECHONET Lite object converted through mapping into a UPnP device.

- UPnP Device-based Method

A method to publish functions of ECHONET Lite devices to the UPnP side using an ECHONET Lite-UPnP gateway.

- Property type

The type of an ECHONET property classified based on its content.

- ECHONET Lite DCP

The UPnP Device Control Protocol, which defines the UPnP commands for ECHONET Lite devices.

Chapter 3 UPnP Device-based Method

3.1 Concept

This chapter specifies the requirements for ECHONET Lite-UPnP gateways for the case where they are used as UPnP Device-based Method gateways. **Fig. 3.1** shows an example system configuration for the UPnP Device-based Method.

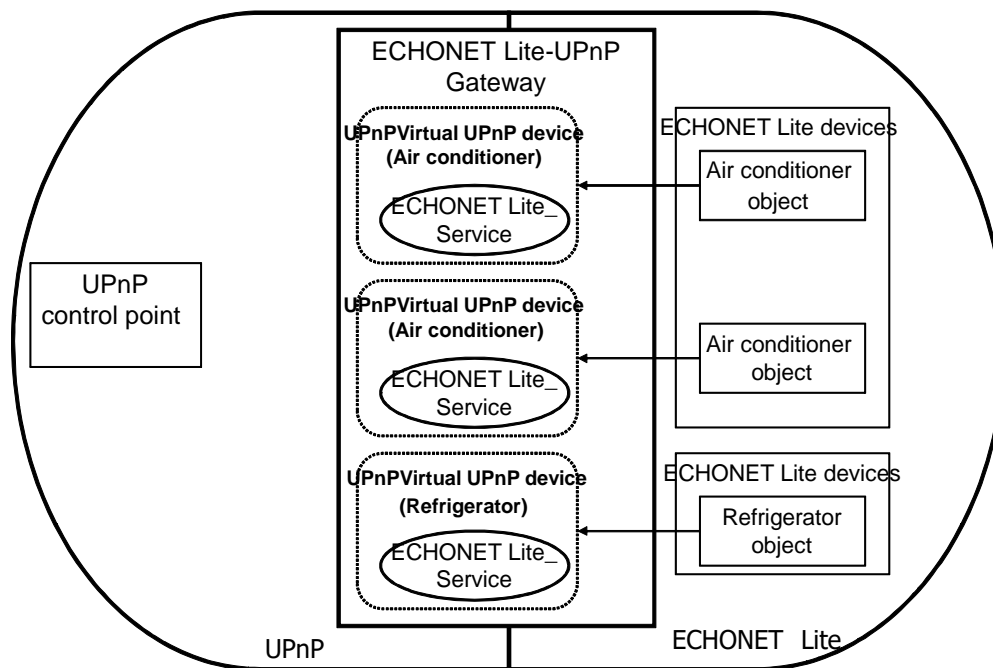

Fig. 3.1 Example System Configuration for the UPnP Device-based Method

The ECHONET Lite-UPnP gateway provides services of ECHONET Lite devices in a UPnP network as virtual UPnP devices. In the case of an ECHONET Lite device equipped with two or more ECHONET objects, the ECHONET Lite-UPnP gateway provides each of the ECHONET objects as a separate virtual UPnP device (see **Fig. 3.1**).

Each ECHONET Lite device can be identified with the combination of the ECHONET Lite address (EA) and ECHONET object code (EOJ). Each virtual UPnP device can be identified with the unique device UUID value assigned by the ECHONET Lite-UPnP gateway. Therefore, the ECHONET Lite-UPnP gateway can establish a one-to-one association between each ECHONET Lite device and the corresponding virtual UPnP device by means of mappings between combinations of ECHONET Lite addresses and ECHONET object code values used in the ECHONET Lite and UPnP device UUID values.

XML Descriptions to publish device data and service data of virtual UPnP devices are created according to certain rules. These rules are specified for each ECHONET property type. Even when new device specifications are added, ECHONET Lite properties can be mapped into

XML Descriptions in a formulaic way simply by classifying the ECHONET Lite properties into types.

The requirements for device object names, ECHONET property names and ECHONET Lite data names used for publication to the UPnP side were newly defined in Appendix B to the ECHONET Lite Specification.

3.2 Classification of ECHONET Lite Properties

This section describes the method to map ECHONET Lite properties into XML Service Descriptions in a formulaic way at the time of publication in a UPnP network of services that an ECHONET Lite device can perform. To achieve such mappings, it is necessary to define the following:

- Constituent elements of XML Service Descriptions
- dataType
- “VariableName” naming rules
- “Action” naming rules

With regard to the “VariableName” and “Action” naming rules, mappings can be achieved by classifying ECHONET Lite properties by property type as described in Section 3.2.1. With regard to the “constituent elements” and “dataType,” mappings can be achieved by classifying ECHONET Lite properties by data type as described in Section 3.2.2. Therefore, these Specifications for ECHONET Lite-UPnP Gateways use the following two classification methods:

- ECHONET property type-based classification
- Data type-based classification

With regard to arrays, each of the array elements is regarded as an independent property and the classification rules are applied accordingly.

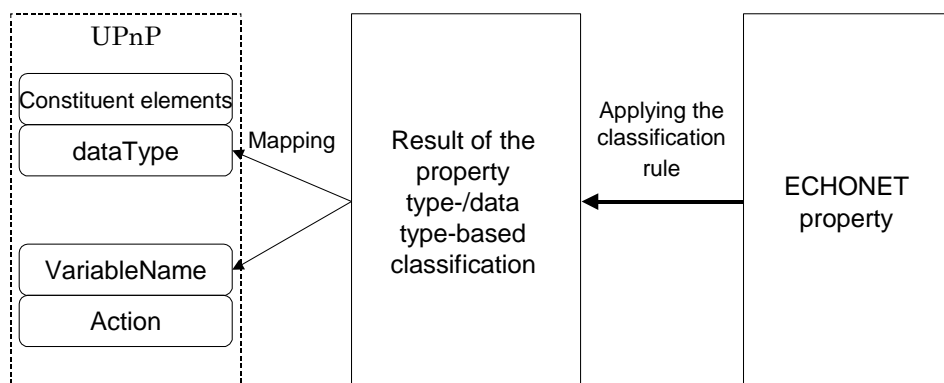

Fig. 3.2 Conceptual Diagram of ECHONET Property Classification

(1) ECHONET property type-based classification

The “ECHONET property type-based classification” method classifies ECHONET Lite properties into property types based on their contents and defines the property type on an ECHONET property by ECHONET property basis. The “VariableName” and “Action” naming rules are specified for each property type. By storing application templates for each of the defined property types, an application program that controls devices can automatically construct the necessary application program when a new device is added.

(2) Data type-based classification

The “data type-based classification” method classifies ECHONET Lite properties by ECHONET property data type and defines the dataType and constituent elements of the XML Service Description based on the classification result.

When a new ECHONET device object is added, the ECHONET Lite properties must be classified according to the classification rules specified below as well as with the existing ECHONET property definitions.

3.2.1 ECHONET property type-based classification

The “ECHONET property type-based classification” method classifies ECHONET Lite properties based on their contents taking into account the possibility that an application may be constructed at a UPnP control point. In this method, ECHONET Lite properties are classified into the following 10 “property types” according to the classification rules described below.

(1) Numerical value type

A “numerical value type” property is a property whose content is a numerical value. The Data Type differs depending on whether or not the value is an integer (whether or not the value has decimal places), whether the value is signed or unsigned and the byte size of the data.

(2) Date type

A “date type” property is a property whose content is data that indicates a date. The Data Type is “Date.” The data format for describing date type properties in XML Descriptions shall be yyyy-mm-dd (year – month – day), which is the format specified by ISO8601.

(3) Time type

A “time type” property is a property whose content is the time of the day or a time length. The Data Type is “Time.” The data format for describing time type properties in XML Descriptions shall be hh-mm-ss (hour – minute – second), which is the format specified by ISO8601.

(4) Level type

A “level type” property is a property which uses “non-numerical value” data that indicates a relative size or relative strength to control an ECHONET Lite device or reference the statuses of ECHONET Lite devices. The Data Type is “String.” An example is the “detection threshold level” property.

(5) Character type

A “character type” property is a property which acquires character string data from ECHONET Lite devices or controls character string data in ECHONET Lite devices. Examples include the “product code” and “production number” properties. The Data Type is “String.”

(6) Reset type

A “reset type” property is a property used to perform resets for a certain state by controlling an ECHONET Lite device using a single defined value. The Data Type is “String.”

(7) Switch type

A “switch type” property is a property which controls an ECHONET Lite device by switching between two values or acquires a value out of a pair of values held by an ECHONET Lite device. Examples include “operation status” and “fault status.” The Data Type is “String.”

(8) Selection type

A “selection type” property is a property which controls an ECHONET Lite device by selecting a value from three or more values or acquires a value out of a set of three or more values held by an ECHONET Lite device. An example is the “installation location” property. The Data Type is “String.”

(9) Composite type

A “composite type” property is a property which has two or more settings and/or pieces of data with each of them contained in the specified byte(s) or bit(s). Examples include the “rated power consumption” property, which assigns 2 bytes to each of the property values and the “implemented air purification method” property, which assigns 1 bit to each of the property values. Composite type properties are made by combining types selected out of the types described in “(1) Numerical value type” to “(8) Selection type” above.

(10) ‘Others’ type

An “others’ type” property is a property that does not fall under any of the types described in “(1) Numerical value type” to “(9) Composite type” above. The ECHONET property value of such a property shall not be converted into a character string and the binary value

defined in the ECHONET Lite shall be published in the UPnP network. The Data Type is “bin.hex.”

Table 3.1 shows a list of property types.

Table 3.1 List of the Property Types

Property type	Explanation
Numerical value type	Used for numerical value-related control/referencing.
Date type	Used for date-related control/referencing.
Time type	Used for time-related control/referencing.
Level type	Used for level-related control/referencing.
Character type	Uses character string-based representation. There is no EDT option.
Reset type	There is one EDT option. The access rule is Set only.
Switch type	There are two EDT options.
Selection type	There are three or more EDT options.
Composite type	Has two or more settings and/or pieces of data. Each of the settings/pieces of data is contained in the specified byte(s) or bit(s).
‘Others’ type	Properties that do not fall under any of the types listed above.

ECHONET Lite properties must be classified into property types in a formulaic way according to the classification rules described below referring to the list of ECHONET Lite properties shown in Appendix to the ECHONET Lite Specification. There are 10 classification rules, namely, Rule 1 to Rule 10. These must be applied in ascending order starting with Rule 1.

First, the properties shall be selected which have 2 or more settings and/or pieces of data with each of them contained in the specified byte(s) or bit(s) (Rule 1). The ECHONET Lite properties selected shall be defined as composite type properties. However, properties which have more than 10 settings and/or pieces of data shall be defined as ‘others’ type properties. Each of the settings and pieces of data contained in a composite type property shall be classified into the applicable one of the “numerical value” to “selection” types described below.

Next, the properties shall be selected for which a unit is specified in the table shown in the Appendix (Rule 2). The ECHONET Lite properties selected shall be defined as numerical value type properties.

Next, the properties shall be selected for which a date format is specified in the “Contents of property” column of the table shown in the Appendix (Rule 3). The ECHONET Lite properties selected shall be defined as date type properties.

Next, the properties shall be selected for which a time format is specified in the

“Contents of property” column of the table shown in the Appendix (Rule 4). The ECHONET Lite properties selected shall be defined as time type properties.

Next, the properties shall be selected whose content is “non-numerical value” data that indicates a relative size or relative strength (Rule 5). The ECHONET Lite properties selected shall be defined as level type properties.

Next, the properties shall be selected whose content is treated as a numerical value even though no unit is specified in the table shown in the Appendix (Rule 6). The ECHONET Lite properties selected shall be defined as numerical value type properties.

Next, the properties shall be selected for which only one setting option is specified (Rule 7). The ECHONET Lite properties selected shall be defined as reset type properties.

Next, the properties shall be selected for which two setting options are specified (Rule 8). The ECHONET Lite properties selected shall be defined as switch type properties.

Next, the properties shall be selected for which three or more setting options are specified (Rule 9). The ECHONET Lite properties selected shall be defined as selection type properties.

Lastly, the properties shall be selected for which an explanation is provided on the property content but no setting option is specified (Rule 10). The ECHONET Lite properties selected shall be defined as character type properties.

All properties that remain undefined after applying Rule 10 shall be defined as ‘Others’ type properties.

Fig. 3.3 shows a flowchart of the classification process described above.

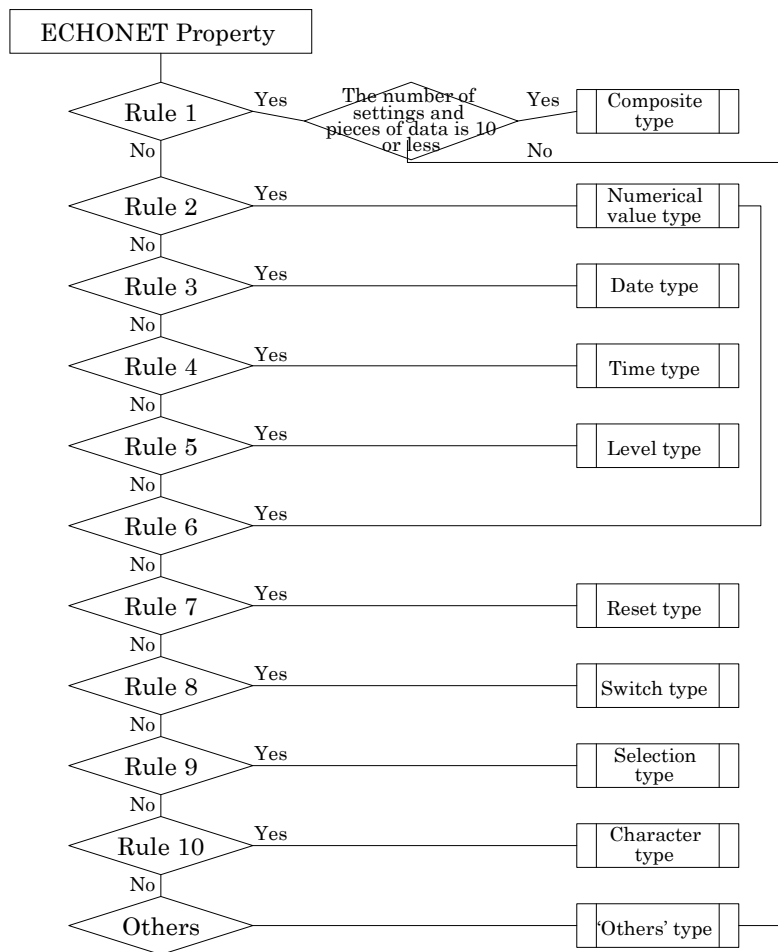

Fig. 3.3 The Rules for Classifying Properties into Property Types

Table 3.2 summarizes the 10 classification rules.

Table 3.2 The Rules for Classifying Properties into Property Types

Rule	Relevant type	Explanation
Rule 1	Composite type	Properties which have two or more and 10 or less settings or pieces of data with each of them contained in the specified byte(s) or bit(s) Each of the settings and pieces of data contained in a composite type property shall be classified into the applicable property type according to Rules 2 to 10.
Rule 2	Numerical value type	Properties for which a unit is specified in the table shown in the Appendix
Rule 3	Date type	Properties for which a date format is specified in the “Contents of property” column of the table shown in the Appendix
Rule 4	Time type	Properties for which a time format is specified in the “Contents

		of property” column of the table shown in the Appendix
Rule 5	Level type	Properties whose content is “non-numerical value” data that indicates a relative size or relative strength
Rule 6	Numerical value type	Properties whose content is treated as a numerical value even though no unit is specified in the table shown in the Appendix
Rule 7	Reset type	Properties for which only one setting option is specified in the “Contents of property” column of the table shown in the Appendix
Rule 8	Switch type	Properties for which two setting options are specified in the “Contents of property” column of the table shown in the Appendix
Rule 9	Selection type	Properties for which three or more setting options are specified in the “Contents of property” column of the table shown in the Appendix
Rule 10	Character type	Properties for which an explanation is provided on the property content but no setting option is specified in the “Contents of property” column of the table shown in the Appendix

3.2.2 Data type-based classification

The “data type-based classification” method classifies ECHONET Lite properties by data type taking into account descriptions in XML Service Descriptions. In this method, ECHONET Lite properties are classified into the following six “data types” according to the classification rules described below. The data type and constituent elements of the XML Service Description are determined based on the classification result.

(1) AVR type

An “AVR type” property is an ECHONET property whose content as specified in the “Contents of property” column of the table shown in the Appendix is a numerical value and for which a property value range is specified in the “Contents of property” column.

However, note that ECHONET Lite device property value ranges do not necessarily match the ECHONET Lite Specification. In addition, in communications based on this version of the ECHONET Lite Specification, it is not possible to acquire property value range data via the network. For this reason, it is permitted to describe ECHONET Lite properties which should ordinarily be classified into the AVR type as value type properties.

When describing an AVR type property in an XML Service Description, the “allowedValueRange” element shall be described in the “serviceStateTable” element.

(2) Value type

A “value type” property is an ECHONET property whose content as specified in the “Contents of property” column of the table shown in the Appendix is a numerical value and for which no property value range is specified in the “Contents of property” column.

When describing a value type property in an XML Service Description, the “allowedValueRange” and “allowedValueList” elements shall not be described in the “serviceStateTable” element.

(3) Date type

A “date type” property is an ECHONET property whose content as specified in the “Contents of property” column of the table shown in the Appendix is data that indicates a date, time or time length.

When describing a date type property in an XML Service Description, the “allowedValueRange” and “allowedValueList” elements shall not be described in the “serviceStateTable” element.

(4) AVL type

An “AVL type” property is an ECHONET property whose content as specified in the “Contents of property” column of the table shown in the Appendix is not a numerical value, date, time or time length and for which property value options are specified in the “Contents of property” column.

When describing an AVL type property in an XML Service Description, the “allowedValueList” element shall be described in the “serviceStateTable” element.

(5) String type

A “string type” property is an ECHONET property whose content as specified in the “Contents of property” column of the table shown in the Appendix is not a numerical value, date, time or time length and for which no property value option is specified in the “Contents of property” column.

When describing a string type property in an XML Service Description, the “allowedValueRange” and “allowedValueList” elements shall not be described in the “serviceStateTable” element.

(6) “Others” type

All ECHONET Lite properties classified into the “others” property type shall be regarded as properties that belong to the “others” data type.

ECHONET Lite properties must be classified in a formulaic way according to the classification rules described below by referring to the list of ECHONET Lite properties shown in the Appendix.

First, the properties whose property type is “others” shall be defined as belonging to the “others” data type.

Next, the ECHONET Lite properties shall be selected whose content as specified in the “Contents of property” column of the table shown in the Appendix is a numerical value. Of

the properties selected, the ones for which a numerical value range is specified in the “Contents of property” column shall be defined as AllowedValueRange type (hereinafter referred to as “AVR type”) properties and the ones for which no numerical value range is specified shall be defined as value type properties. However, in communications based on the current version of the ECHONET Lite Specification, ECHONET Lite properties for which a numerical value range is defined in the ECHONET Lite Specification may also be published as value type properties to UPnP, because it is not possible to acquire via the network value ranges in which ECHONET Lite devices can operate.

Next, the ECHONET Lite properties shall be selected whose content as specified in the “Contents of property” column of the table shown in the Appendix is date-, time- or time length-related data. The ECHONET Lite properties selected shall be described as date type properties.

Of the remaining ECHONET Lite properties, the ones for which property options are specified in the “Contents of property” column of the table shown in the Appendix shall be defined as AllowedValueList type (hereinafter referred to as “AVL type”) properties and the ones for which no property option is specified in the “Contents of property” column shall be defined as string type properties.

Fig. 3.4 shows a flowchart of the classification process described above. For the XML Service Description formats for the individual types, refer to Chapter 6.

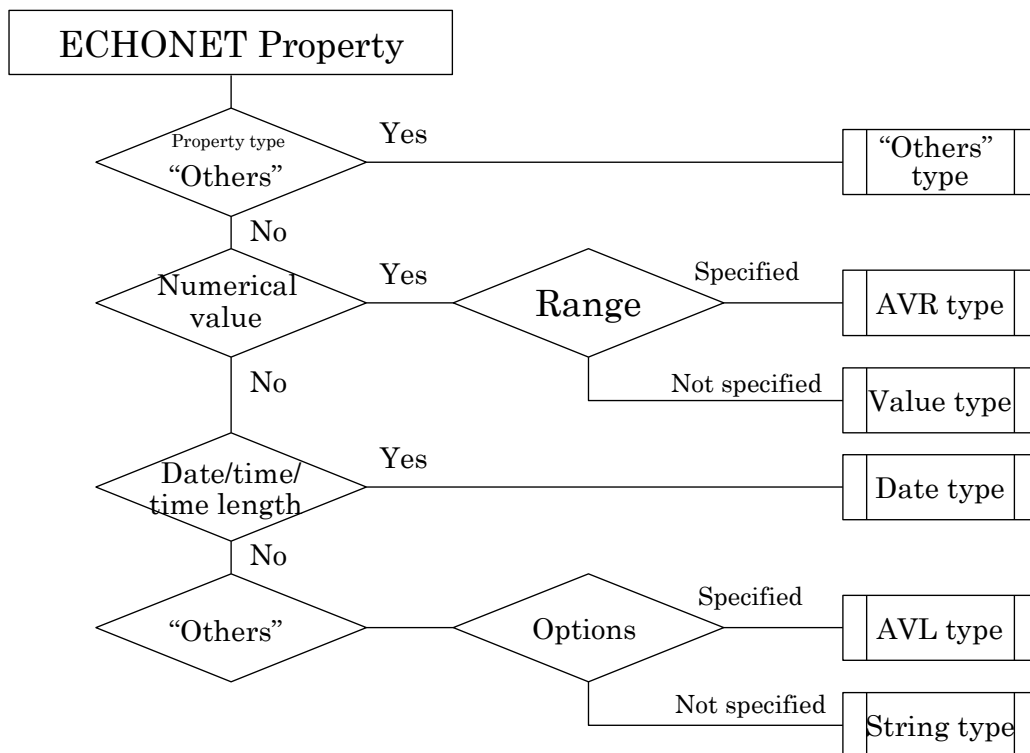

Fig. 3.4 The Rules for Classifying Properties into Data Types

3.3 Naming Rules

To publish device data and service data of an ECHONET Lite device in a UPnP network, it is necessary to describe the ECHONET device object name, ECHONET property name and ECHONET Lite data using a description method that is highly compatible with UPnP.

In addition, to allow easy creation of VariableNames and Action names for existing and newly added ECHONET Lite properties, a method is necessary which achieves formulaic conversions that use names defined by the current ECHONET Lite Specification. For these reasons, the basic rules specified below must be followed when describing data.

Firstly, the ECHONET device object names must be reflected in the Device Type names. In addition, the property type-based classification results and the ECHONET property names must be reflected in the VariableNames and Action names. ECHONET Lite properties classified into property types as described in Section 3.2.1 must be reflected in XML Service Descriptions through the use of combinations of Action name, VariableName and dataType. The naming rules are as specified below.

3.3.1 Naming rules necessary for XML Device Descriptions

The rules for describing services representing the ECHONET Lite and ECHONET Lite device names when describing data in XML Device Descriptions are as follows:

Each ECHONET Lite device shall be described as “ECHONET Lite_*Appliance*.” The ECHONET device object name shall be entered in the “*Appliance*” section. The ECHONET device object names to be stored in the “*Appliance*” section were created based on the Appendix. These are shown in Appendix 2.

The Service Type held by each ECHONET Lite_*Appliance* shall be ECHONET Lite_*Service*.

3.3.2 Naming rules based on ECHONET property type-based classification

The VariableName and Action name are defined based on the ECHONET property type-based classification result. Table 3.3 shows the naming rules for the individual ECHONET property types.

Table 3.3 Naming Rules for VariableName and Action

Property Type	Object	Action prefix
Numerical value type	Type of numerical value	Write / Read
Date type	Date	Set / Get
Time type	Time	Set / Get
Level type	Level	Set / Get

Character type	Code	Set / Get
Reset type	--	Reset
Switch type	Status	Set / Get
Selection type	Status	Set / Get
'Others' type	--	Set / Get

The principles for creating VariableNames are as follows:

- VariableNames must not be unnatural as UPnP Variable Names.
- It must be possible to create VariableNames in a formulaic way.
- VariableNames must be such that their meanings can be inferred in English.
- The number of characters must be less than 32 including the Action prefix.
- With regard to non-array type ECHONET Lite properties, a VariableName must be created for each ECHONET property.
- With regard to array type ECHONET Lite properties, a VariableName must be created for each array element.

On the basis of the principles listed above, the following rules were established:

First, the appropriate “object” indicating the content of the property must be selected from Table 3.3 according to the property type. Then, the VariableName must be created by decomposing the property name into words, selecting the words necessary to construct a VariableName from which the meaning can be inferred in English, combining the words in the order they appear in the original property name and then suffixing the “object” selected from Table 3.3. The results are shown in Appendix 2.

The naming rule for Action is as follows:

Each Action name shall consist of the Action prefix followed by the VariableName.

3.3.3 Definition of the dataType based on data type-based classification

The dataType is defined based on the data type-based classification result.

Table 3.4 List of Data Types

Data type-based Classification	dataType
AVR type	ui1, ui2, ui4, i1, i2, i4, float
Value type	ui1, ui2, ui4, i1, i2, i4, float
Date type	Time / Date
AVL type	String
String type	String
'Others' type	bin.hex

The dataType for an AVR/value type property shall be determined based on the ECHONET property value range and data size. The dataType (Time or Date) for a date type property shall be determined based on the content of the ECHONET property.

3.3.4 Argument naming rules

In XML Service Descriptions, parameters for actions are defined in ArgumentLists. This section defines the naming rules for Arguments, which are sub-elements of ArgumentLists. The number of characters of each Argument name must be less than 32.

- Non-composite type ECHONET Lite properties:

Each Argument name must consist of the word “New” (in the case where the purpose is to control devices) or “Current” (in the case where the purpose is to reference the statuses of devices) followed by “*VariableName*,” which is the relevant VariableName. For example, when the purpose is to control an ECHONET property whose VariableName is “OperationStatus,” the Argument name is “NewOperationStatus.”

- Composite type ECHONET Lite properties:

Each Argument name must consist of the word “New” (in the case where the purpose is to control devices) or “Current” (in the case where the purpose is to reference the statuses of devices) followed by the “adjective” followed by “*VariableName*,” which is the relevant VariableName. The adjective is a word that indicates one of the items that comprise the property. For example, in the case where the purpose is to control an ECHONET property that defines the rated power consumption values for the cooling, heating, dehumidification and air circulation modes using 2 bytes for each mode, the adjectives are “Cool,” “Heat,” “Dehumid” and “Blast,” respectively, and the corresponding Argument names are “NewCoolRatedConsumpPower,” “NewHeatRatedConsumpPower,” “NewDehumidRatedConsumpPower” and “NewBlastRatedConsumpPower,” respectively.

3.4 Summary of the relationships between property types, data types, objects, Action prefixes and dataTypes

Table 3.5 summarizes the relationships between the property types, data type-based classification (explained in “3.2 Classification of ECHONET Lite Properties), objects, Action prefixes and dataTypes (explained in “3.3 Naming Rules”).

**Table 3.5 Relationships between Property types, Data types, Objects,
 Action prefixes and dataTypes**

Property Type	Data type-based Classification	Object	Action prefix	dataType
Numerical value type	AVR / Value type	Type of numerical value	Write / Read	ui1, ui2, ui4, i1, i2, i4, float
Date type	Date type	Date	Set / Get	Date
Time type	Date type	Time	Set / Get	Time
Level type	AVL type	Level	Set / Get	String
Character type	String type	Code	Set / Get	String
Reset type	AVL type	--	Reset	String
Switch type	AVL type	Status	Set / Get	String
Selection type	AVL type	Status	Set / Get	String
'Others' type	'Others' type	--	Set / Get	bin.hex

Chapter 4 Processing for ECHONET Lite-UPnP Gateways for the UPnP Device-based Method

This chapter specifies the requirements regarding the processing to be performed in the case where an ECHONET Lite-UPnP gateway operates as a UPnP device:

- Plug and play processing
- Control of ECHONET Lite devices from UPnP control points
- Notifying the statuses of ECHONET Lite devices to UPnP control points

4.1 Plug and Play Processing

As shown in **Fig. 3.1**, devices in a UPnP Device-based Method system can be classified into “UPnP control points” (audiovisual devices), “ECHONET Lite-UPnP gateways” and “ECHONET Lite devices.” The following sections specify the requirements regarding the plug and play processing to be performed when an ECHONET Lite-UPnP gateway connects to a network and that to be performed when an ECHONET Lite device connects to a network. This ECHONET Lite Specification does not specify requirements regarding the processing to be performed when a UPnP control point connects to a network, because there is no such processing to be performed on the ECHONET Lite side.

The processing to be performed when an ECHONET Lite device disconnects from a network is beyond the scope of the ECHONET Lite Specification.

4.1.1 Plug and play processing to be performed when an ECHONET Lite-UPnP gateway connects to a network

This section specifies the requirements regarding the plug and play processing to be performed when an ECHONET Lite-UPnP gateway connects to an ECHONET Lite network. For details of the processing to be performed when an ECHONET Lite-UPnP gateway connects to an ECHONET Lite network, refer to Part 2, Section 5.3 of the ECHONET Lite Specification.

Each ECHONET Lite-UPnP gateway connects to a UPnP network after connecting to an ECHONET Lite network. The ECHONET Lite-UPnP gateway-related processing to be performed when an ECHONET Lite-UPnP gateway connects to a UPnP network and the sequence are described below. **Fig. 4.1** shows the sequence.

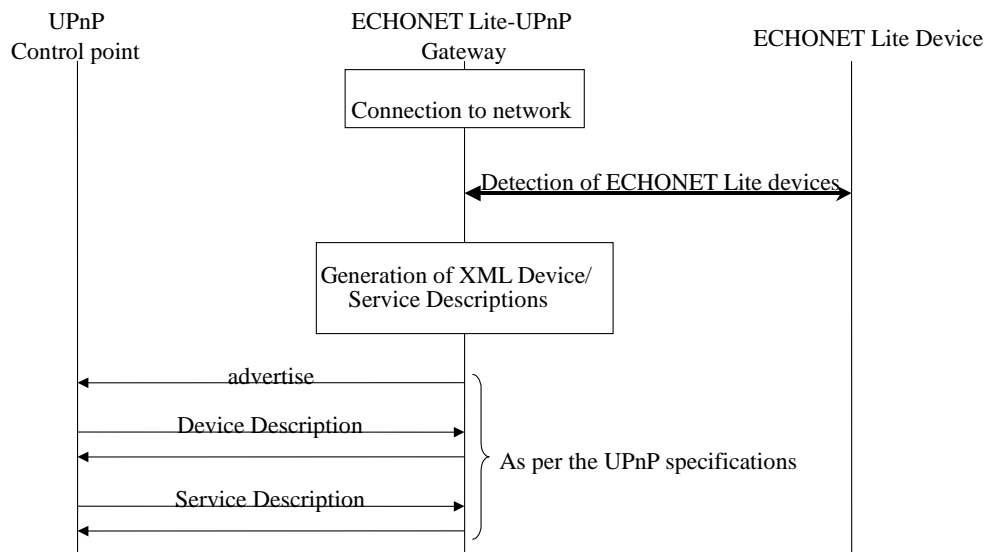

Fig. 4.1 Sequence to Be Followed when an ECHONET Lite-UPnP Gateway Connects to a Network

When an ECHONET Lite-UPnP gateway connects to a UPnP network, it shall detect the ECHONET Lite devices connected to the ECHONET Lite network and generate XML Device Descriptions and XML Service Descriptions based on the result. Or, alternatively, the ECHONET Lite-UPnP gateway may use the XML Device Descriptions and XML Service Descriptions for the ECHONET Lite devices stored at the time of the last startup. One way for the ECHONET Lite-UPnP gateway to detect the connected ECHONET Lite devices is to transmit at the time of the startup a home node instance list S property read request to the node profile class in the form of an intra-domain simultaneous broadcast in the ECHONET Lite network and receive responses from the ECHONET Lite devices. The ECHONET Lite-UPnP gateway shall multicast an “advertise” after storing the XML Device Descriptions and XML Service Descriptions for the ECHONET Lite devices connected to the ECHONET Lite network. The processing after transmission of the “advertise” shall be as per the UPnP specifications.

4.1.2 Plug and play processing to be performed when an ECHONET Lite device connects to a network

The ECHONET Lite-UPnP gateway-related processing to be performed when an ECHONET Lite device connects to a network and the sequence are described below. **Fig. 4.2** shows the sequence.

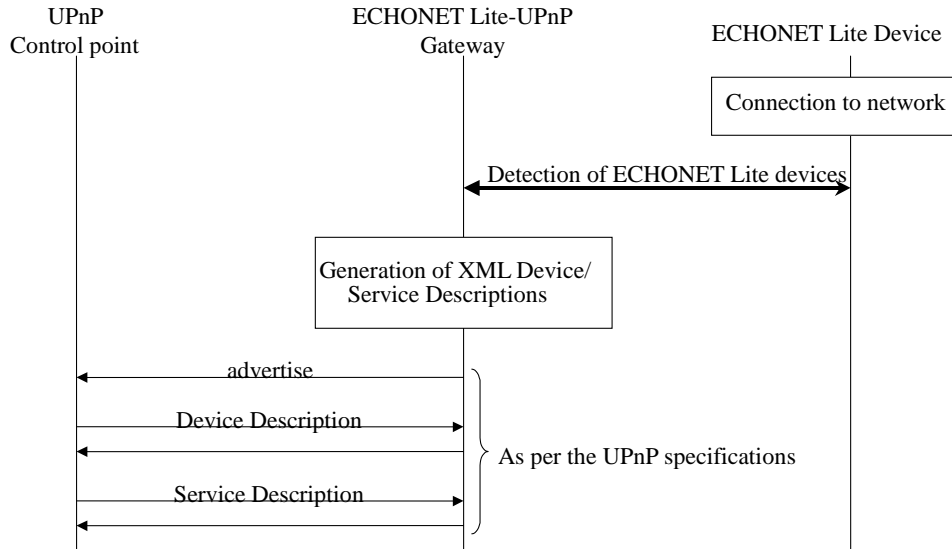

Fig. 4.2 Sequence to Be Followed when an ECHONET Lite Device Connects to a Network

When an ECHONET Lite-UPnP gateway detects that an ECHONET Lite device has connected to a network, it shall generate the XML Device and Service Descriptions for the ECHONET Lite device. Or, alternatively, the ECHONET Lite-UPnP gateway may use the XML Device and Service Descriptions for the ECHONET Lite device it had at the time of the last startup of the ECHONET Lite device. One way for the ECHONET Lite-UPnP gateway to detect that an ECHONET Lite device has connected to a network is to receive an instance change class notification transmitted by the ECHONET Lite device when the ECHONET Lite device starts up and to use the notification as the trigger for ECHONET Lite device detection.

The ECHONET Lite-UPnP gateway shall multicast an “advertise” after describing the XML Device and Service Descriptions. The processing after transmission of the “advertise” shall be as per the UPnP specifications.

4.2 Control of ECHONET Lite Devices from UPnP Control Points

4.2.1 Control of ECHONET Lite devices

This section specifies the requirements regarding the ECHONET Lite-UPnP gateway-related processing to be performed when a UPnP control point controls an ECHONET Lite device via an ECHONET Lite-UPnP gateway, as well as the sequence to be followed.

If an ECHONET Lite-UPnP gateway receives an “action request” from a UPnP control point, the ECHONET Lite-UPnP gateway shall control the ECHONET Lite device(s) according to the synchronous or asynchronous type sequence described below.

4.2.1.1 Synchronous type sequence-based control of ECHONET Lite devices

Fig. 4.3 shows the synchronous type sequence for controlling ECHONET Lite devices.

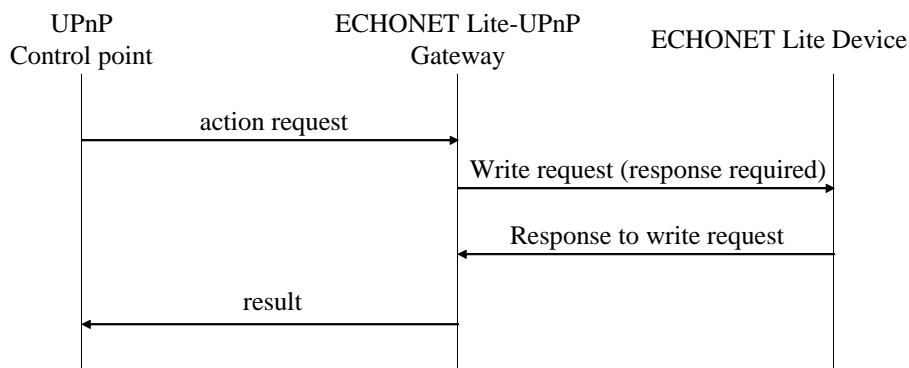

Fig. 4.3 Synchronous Type Sequence

The operation of an ECHONET Lite-UPnP gateway in the case where the synchronous type sequence is used is as follows.

If the ECHONET Lite-UPnP gateway receives an “action request” from a UPnP control point, the ECHONET Lite-UPnP gateway shall perform a conversion to the ECHONET Lite protocol data format and transmit to the ECHONET Lite device a write request message that requires a response. If the ECHONET Lite-UPnP gateway subsequently receives from the ECHONET Lite device a response to the write request, the ECHONET Lite-UPnP gateway shall send a “result” to the UPnP control point from which the “action request” was sent.

4.2.1.2 Asynchronous type sequence-based control of ECHONET Lite devices

Fig. 4.4 shows the asynchronous type sequence for controlling ECHONET Lite devices.

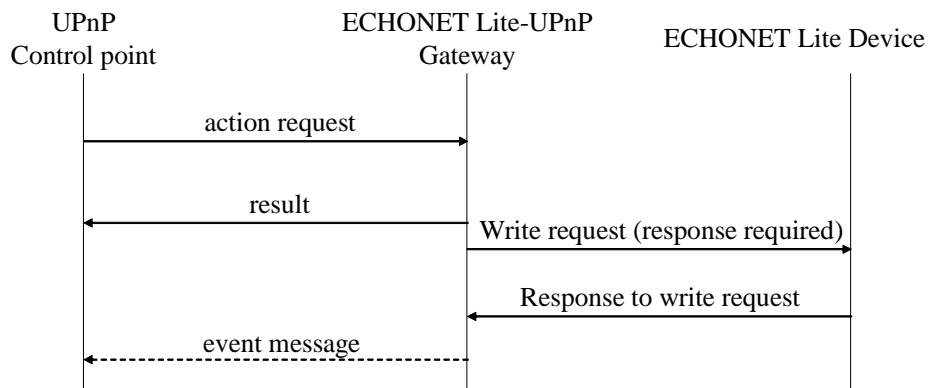

Fig. 4.4 Asynchronous Type Sequence

The operation of an ECHONET Lite-UPnP gateway in the case where the asynchronous type sequence is used is as follows.

If the ECHONET Lite-UPnP gateway receives an “action request” from a UPnP control point, the ECHONET Lite-UPnP gateway shall send a “result” to the UPnP control point from which the “action request” was sent. At the same time, the ECHONET Lite-UPnP gateway shall perform a conversion to the ECHONET Lite protocol data format and transmit to the ECHONET Lite device a write request message that requires a response. If the ECHONET Lite-UPnP gateway subsequently receives a response from the ECHONET Lite device to the write request and the ECHONET Lite-UPnP gateway has accepted a “subscription request” by that point, the ECHONET Lite-UPnP gateway shall notify the UPnP control point of the control action by sending an “event message.”

4.2.2 Referencing the statuses of ECHONET Lite devices

This section specifies the requirements regarding the ECHONET Lite-UPnP gateway-related processing to be performed when a UPnP control point references the status of an ECHONET Lite device via an ECHONET Lite-UPnP gateway, as well as the sequence to be followed.

If an ECHONET Lite-UPnP gateway receives an “action request” from a UPnP control point, the ECHONET Lite-UPnP gateway shall reference the status(es) of the ECHONET Lite device(s) according to the synchronous or asynchronous type sequence described below.

4.2.2.1 Synchronous type sequence-based referencing of the statuses of ECHONET Lite devices

Fig. 4.5 shows the synchronous type sequence for referencing the statuses of ECHONET Lite devices.

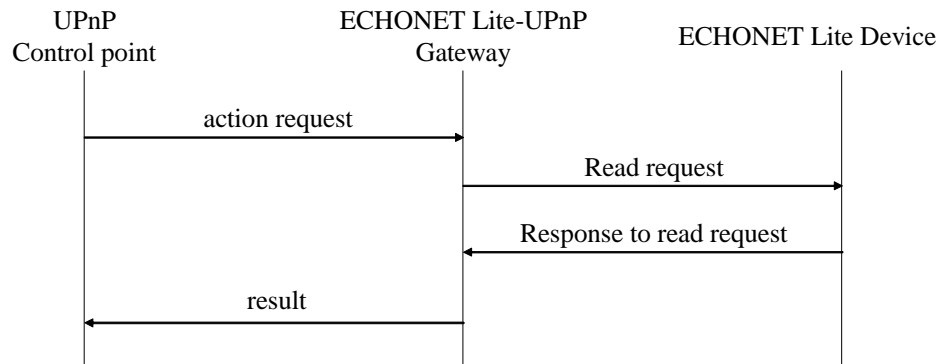

Fig. 4.5 Synchronous Type Sequence

The operation of an ECHONET Lite-UPnP gateway in the case where the synchronous type sequence is used is as follows.

If the ECHONET Lite-UPnP gateway receives an “action request” from a UPnP control point, the ECHONET Lite-UPnP gateway shall perform a conversion to the ECHONET Lite protocol data format and transmit to the ECHONET Lite device a read request message that requires a response. If the ECHONET Lite-UPnP gateway subsequently receives from the ECHONET Lite device a response to the read request, the ECHONET Lite-UPnP gateway shall send a “result” to the UPnP control point from which the “action request” was sent.

4.2.2.2 Asynchronous type sequence-based referencing of the statuses of ECHONET Lite devices

Fig. 4.6 shows the asynchronous type sequence for referencing the statuses of ECHONET Lite devices.

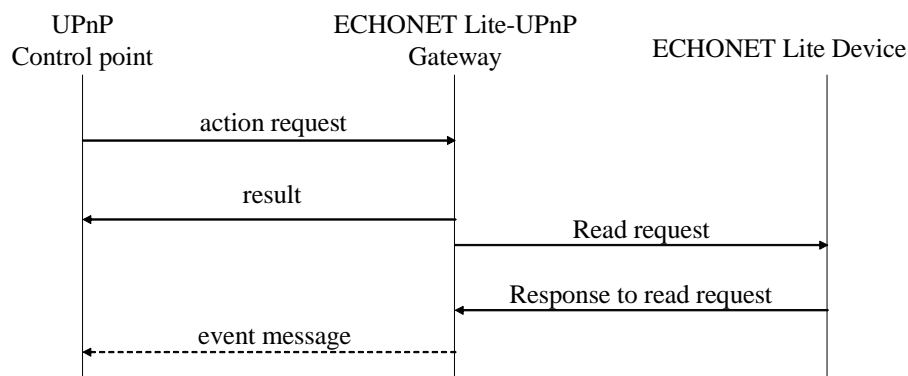

Fig. 4.6 Asynchronous Type Sequence

The operation of an ECHONET Lite-UPnP gateway in the case where the asynchronous type sequence is used is as follows:

If the ECHONET Lite-UPnP gateway receives an “action request” from a UPnP control point, the ECHONET Lite-UPnP gateway shall send a “result” to the UPnP control point from which the “action request” was sent.

At the same time, the ECHONET Lite-UPnP gateway shall perform a conversion to the ECHONET Lite protocol data format and transmit to the ECHONET Lite device a read request message that requires a response. If the ECHONET Lite-UPnP gateway subsequently receives a response from the ECHONET Lite device to the read request and the ECHONET Lite-UPnP gateway has accepted a “subscription request” by that point, the ECHONET Lite-UPnP gateway shall notify the UPnP control point of the device status(es) shown in the response by sending an “event message.”

In the case where an ECHONET Lite-UPnP gateway operates according to the asynchronous type sequence, it shall store the statuses of ECHONET Lite devices. This is because it is necessary for the ECHONET Lite-UPnP gateway to include the status(es) of the relevant device(s) in each “result” response it sends immediately after it receives an “action request.”

4.3 Notifying the statuses of ECHONET Lite devices to UPnP control points

This section specifies the requirements regarding the ECHONET Lite-UPnP gateway-related processing to be performed when an ECHONET Lite-UPnP gateway notifies a UPnP control point of the status of an ECHONET Lite device, as well as the sequence to be followed.

No requirement is specified as to when to make a notification (by sending an “event message”), but it is recommended that an “event message” for notification be sent:

- When a status change notification is received from an ECHONET Lite device;
- When an ECHONET Lite-UPnP gateway acquires the status of an ECHONET Lite device and detects that the status of the ECHONET Lite device has changed;
- When an ECHONET Lite-UPnP gateway receives a response from an ECHONET Lite device while the ECHONET Lite-UPnP gateway is operating according to the asynchronous type sequence (see **Fig. 4.4** and **Fig. 4.6**).

Fig. 4.7 shows the sequence for the case where the ECHONET Lite-UPnP gateway sends an “event message” to the UPnP control point after receiving a status change notification from an ECHONET Lite device.

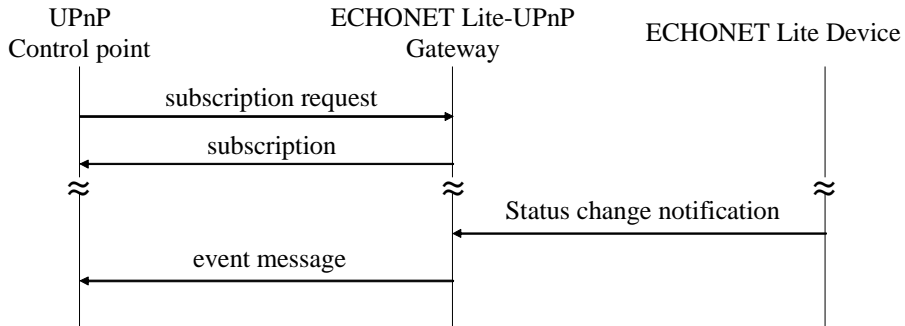

Fig. 4.7 Sequence for the Case where “event message”-based Notifications Are Made

The ECHONET Lite-UPnP gateway shall send a unicast “event message” to the UPnP control points with which a subscription request has been registered.

Chapter 5 Device Template

The design policy for the publication of information on ECHONET Lite devices to the UPnP side is that the corresponding virtual UPnP devices must be specified as UPnP root devices for each ECHONET device object whenever information on ECHONET Lite devices is published to the UPnP side. Each virtual UPnP device shall provide its ECHONET Lite Service.

5.1 Definition of Device

5.1.1 Device Type

Devices of the following device type conform to this Device Template:

urn:echonet-gr-jp:device:ECHONET Lite_*Appliance*:1

The domain name (an element unique to the ECHONET Lite) described in XML Device Descriptions shall be “echonet-gr-jp.”

“:1” indicates the version of the specifications. The “*Appliance*” section shall be replaced with the Appliance name specified in Appendix 2. For example, in the case of the home air conditioner class, the “*Appliance*” section shall be replaced with the Appliance name “HomeAirConditioner,” and the Device Type shall therefore be described as:

“urn:echonet-gr-jp:device:ECHONET Lite_ HomeAirConditioner:1.”

5.1.2 Device requirements

Devices that fall under a device type other than “urn:echonet-gr-jp:device:ECHONET Lite_*Appliance*:1” shall be equipped with functions to satisfy the requirements specified below. **Table 5.1** shows the device requirements.

Table 5.1 Device Requirements

DeviceType	Root	Req. or Opt. ¹	ServiceType	Req. or Opt. ¹	Service ID ²
ECHONET Lite_ <i>Appliance</i> :1	Root	R	ECHONET Lite_Service:1	R	ECHONET Lite_ <i>Appliance</i>

1 R = Required, O = Optional, X = Non-standard.

2 Prefixed by urn:echonet-gr-jp:serviceId:.

The “Service ID” for “ECHONET Lite_Service” shall be “urn:echonet-gr-jp:serviceId:ECHONET Lite_*Appliance*.” The “*Appliance*” section shall be replaced with the unique name for the ECHONET Lite device in question which is specified in Appendix 2 to the ECHONET Lite Specification.

For example, in the case of an air conditioner, the “*Appliance*” section shall be replaced

with “HomeAirConditioner,” and the Service ID shall therefore be described as:
“urn:echonet-gr-jp:serviceId:ECHONET Lite_ HomeAirConditioner.”

5.2 XML Device Descriptions

Table 5.2 show the format for XML Device Descriptions for devices described in Section 5.1. Each XML Device Description element shall meet the specifications defined in UPnP Device Architecture Ver. 1.0.

Table 5.2 Format for XML Device Descriptions

```
<?xml version="1.0"?>
<root xmlns="urn:schemas-upnp-org:device-1-0">
  <specVersion>
    <major>1</major>
    <minor>0</minor>
  </specVersion>
  <URLBase>base URL for all relative URLs</URLBase>
  <device>
    <deviceType>urn:echonet-gr-jp:device:ECHONET Lite Appliance:1</deviceType>
    <friendlyName>short user-friendly title</friendlyName>
    <manufacturer>manufacturer name</manufacturer>
    <manufacturerURL>URL to manufacturer site</manufacturerURL>
    <modelDescription>long user-friendly title</modelDescription>
    <modelName>model name</modelName>
    <modelName>model number</modelName>
    <modelURL>URL to model site</modelURL>
    <serialNumber>manufacturer's serial number</serialNumber>
    <UDN>uuid:UUIID/UDN</UDN>
    <UPC>Universal Product Code</UPC>
    <iconList>
      <icon>
        <mimetype>image/format</mimetype>
        <width>horizontal pixels</width>
        <height>vertical pixels</height>
        <depth>color depth</depth>
        <url>URL to icon</url>
      </icon>
      XML to declare other icons, if any, go here
    </iconList>
    <serviceList>
      <service>
        <serviceType>urn:echonet-gr-jp:service:ECHONET Lite_Service:1</serviceType>
        <serviceId>urn:echonet-gr-jp:serviceId:ECHONET Lite Appliance</serviceId>
        <SCPDURL>URL to service description</SCPDURL>
      </service>
    </serviceList>
  </device>
</root>
```

```
        <controlURL>URL for control</controlURL>
        <eventSubURL>URL for eventing</eventSubURL>
    </service>
</serviceList>
    <presentationURL>URL for presentation</presentationURL>
</device>
</root>
```

“UDN” element: When the ECHONET Lite-UPnP gateway detects the connection to a network of an ECHONET Lite device, the ECHONET Lite-UPnP gateway shall generate a unique UUID value for the ECHONET Lite device, store the generated UUID value in the UDN element and describe it in the XML Device Description.

5.3 Example XML Device Description (Air Conditioner)

This section shows an example of an XML Device Description for a virtual UPnP device for an air conditioner (EOJ = 0x013000).

Table 5.3 Example of Actual XML Device Description (Air Conditioner)

```
<root xmlns="urn:schemas-upnp-org:device-1-0">
  <specVersion>
    <major>1</major>
    <minor>0</minor>
  </specVersion>
  <device>
    <deviceType>urn:echonet-gr-jp:device:ECHONET Lite_HomeAirConditioner:1</deviceType>
    <friendlyName>Home Air Conditioner</friendlyName>
    <manufacturer>manufacturer name of air conditioner</manufacturer>
    <manufacturerURL>URL to manufacturer site</manufacturerURL>
    <modelDescription>Home Air Conditioner</modelDescription>
    <modelName>model name of air conditioner</modelName>
    <UDN>uuid:ad82f4cd-bafd-11da-9d2c-000e7b032792</UDN>
    <serviceList>
      <service>
        <serviceType>urn:echonet-gr-jp:service:ECHONET Lite_Service:1</serviceType>
        <serviceId>urn:echonet-gr-jp:serviceId:ECHONET Lite_HomeAirConditioner</serviceId>
        <SCPDURL>/service.xml</SCPDURL>
        <controlURL>/ECHONET Lite/control/ECHONET Lite_HomeAirConditioner1</controlURL>
        <eventSubURL>/ECHONET Lite/Eventing/ECHONET Lite_HomeAirConditioner1</eventSubURL>
      </service>
    </serviceList>
    <presentationURL>/presentation.html</presentationURL>
  </device>
</root>
```

Chapter 6 Service Template

The Service Template is specified below for “ECHONET Lite_Service,” which is a ServiceType held by “ECHONET Lite_Appliance” in this project.

6.1 Definition of Service Model

6.1.1 Service Type

Services of the following Service Type conform to this Device Template:

urn:echonet-gr-jp:service:ECHONET Lite_Service:1

The domain name (an element unique to ECHONET Lite) described in XML Device Descriptions shall be “echonet-gr-jp.”

6.1.2 Service Type requirements

Service Type “ECHONET Lite_Service” shall satisfy the following requirements:

The Variable Name shall be a name created according to the naming rules specified in Section 3.3. For the specifications for Data Type, Allowed Value and Eng. Units, refer to the Appendix and Appendix 2 to the ECHONET Lite Specification.

Table 6.1 State Variables

Variable Name	Req. or Opt. ¹	Data Type	Allowed Value	Default Value	Eng. Units
<i>VariableName</i>	See ECHONET Lite Specification.	See ECHONET Lite Specification.	See ECHONET Lite Specification.	<i>None</i>	See ECHONET Lite Specification.

¹ R = Required, O = Optional, X = Non-standard.

- Variable Name

The character string to be assigned to “*VariableName*” shall be determined based on Appendix 2 to the ECHONET Lite Specification. For example, in the case where the operation status (EPC = 0x80) is described, the VariableName shall be “OperationStatus.”

- Req. or Opt.

The distinction between “required” and “optional” shall be made based on the Appendix to the ECHONET Lite Specification.

- Data Type

Refer to Appendix 2 to the ECHONET Lite Specification.

- Allowed Value

Refer to Appendix 2 to the ECHONET Lite Specification.

- Default Value

No default value is specified for any ECHONET property.

- Eng. Units

Refer to the Appendix to the ECHONET Lite Specification.

6.1.3 Action

Specifies whether the service in question is a service for providing control or for referencing the status in relation to the property specified in the VariableName.

Table 6.2 Description of Action

Name	Req. or Opt.
Set <i>VariableName</i>	Opt.
Get <i>VariableName</i>	Opt.
Write <i>VariableName</i>	Opt.
Read <i>VariableName</i>	Opt.
Reset <i>VariableName</i>	Opt.

- Name

The Action name shall be “Set” or “Write” followed by the Variable Name in the case of control and “Get” or “Read” followed by the Variable Name in the case of referencing the status. In the case of a status reset, the Action name shall be “Reset” followed by the Variable Name. For the rules regarding the prefix to be used, refer to Table 3.3.

- Req. or Opt.

Optional.

○ Set *VariableName*/Write *VariableName*

Used when altering the status of an ECHONET property.

- Arguments

The arguments for the case where the action is Set *VariableName* or Write *VariableName* are as shown in Table 6.3.

Table 6.3 List of Arguments for Control

Argument	Direction	relatedStateVariable
New <i>VariableName</i>	In	<i>VariableName</i>

- + Argument

Indicates the argument. The Argument name shall be “New” followed by the Variable Name (i.e. “New *VariableName*”). However, in the case of a composite type

ECHONET property, the Argument name shall be “New ‘*adjective*’ *VariableName*.”
 For example, in the case of operation status, the Argument name shall be
 “NewOperationStatus.”

+ Direction

The Direction shall be “In” in the case of device control.

+ relatedStateVariable

Indicates the target for reflection after control. This shall be the “*VariableName*.”

However, in the case of a composite type ECHONET property, this shall be the
 “‘*Adjective*’ *VariableName*.”

○ Get *VariableName*/Read *VariableName*

Used when referencing the status of an ECHONET property.

– Arguments

The arguments for the case where the action is Get *VariableName* or Read *VariableName* are as shown in **Table 6.4**.

Table 6.4 List of Arguments for Referencing Statuses

Argument	Direction	relatedStateVariable
Current <i>VariableName</i>	Out	<i>VariableName</i>

+ Argument

Indicates the argument. The Argument name shall be “Current” followed by the
Variable Name (i.e. “Current *VariableName*”). However, in the case of a composite
 type ECHONET property, the Argument name shall be “Current ‘*adjective*’
VariableName.” For example, in the case of operation status, the Argument name shall
 be “CurrentOperationStatus.”

+ Direction

The Direction shall be “Out” in the case of referencing the status of a device.

+ relatedStateVariable

Indicates the target for referencing the state. This shall be the “*VariableName*.”
 However, in the case of a composite type ECHONET property, this shall be the
 “‘*Adjective*’ *VariableName*.”

○ Reset *VariableName*

Used for an ECHONET property status reset. There is no Argument.

6.2 XML Service Descriptions

Table 6.5 shows the format for XML Service Descriptions for ECHONET Lite_Service. The XML Service Description format to use can be determined based on the property type or data type. Each element shall meet the specifications defined in UPnP Device Architecture Ver. 1.0.

Table 6.5 Format for XML Service Descriptions

```

<?xml version="1.0"?>
<scpd xmlns="urn:schemas-upnp-org:service-1-0">
  <specVersion>
    <major>1</major>
    <minor>0</minor>
  </specVersion>
  <actionList>
    <!-- Date type, Time type, Level type, Character type, Selection type, Switch type,
'Others' type -->
    <action>
      <name>Set VariableName</name>
      <argumentList>
        <argument>
          <name>New VariableName</name>
          <direction>in</direction>
          <relatedStateVariable> VariableName</relatedStateVariable>
        </argument>
      </argumentList>
    </action>
    <!--Date type, Time type, Level type, Character type, Selection type, Switch type,
'Others' type -->
    <action>
      <name>Get VariableName</name>
      <argumentList>
        <argument>
          <name>Current VariableName</name>
          <direction>out</direction>
          <relatedStateVariable> VariableName</relatedStateVariable>
        </argument>
      </argumentList>
    </action>
    <!-- Numerical value type -->
    <action>
      <name>Write VariableName</name>
      <argumentList>
        <argument>
          <name>New VariableName</name>
          <direction>in</direction>
          <relatedStateVariable> VariableName</relatedStateVariable>
        </argument>
      </argumentList>
    </action>
  </actionList>
</scpd>

```

```
</argumentList>
</action>
<!-- Numerical value type -->
<action>
  <name>Read VariableName</name>
  <argumentList>
    <argument>
      <name>Current VariableName</name>
      <direction>out</direction>
      <relatedStateVariable> VariableName</relatedStateVariable>
    </argument>
  </argumentList>
</action>
<!-- Reset type -->
<action>
  <name>Reset VariableName</name>
</action>
  Declarations for other actions added by UPnP vendor (if any) go here
</actionList>
<serviceStateTable>
  <!-- AVR type -->
  <stateVariable sendEvents="yes" or "no">
    <name> VariableName</name>
    <dataType>see ECHONET Lite Specifications</dataType>
    <defaultValue>default Value</defaultValue>
    <allowedValueRange>
      <minimum>Minimum Data Value</minimum>
      <maximum>Maximum Data Value</maximum>
      <step>Step Value</step>
    </allowedValueList>
  </stateVariable>
  <!--Value type -->
  <stateVariable sendEvents="yes" or "no">
    <name> VariableName</name>
    <dataType>see ECHONET Lite Specifications</dataType>
    <defaultValue>default Value</defaultValue>
  </stateVariable>
  <!--Date type -->
  <stateVariable sendEvents="yes" or "no">
    <name> VariableName</name>
    <dataType>see ECHONET Lite Specifications</dataType>
    <defaultValue>default Value</defaultValue>
  </stateVariable>
  <!--AVL type -->
  <stateVariable sendEvents="yes" or "no">
    <name> VariableName</name>
    <dataType>string</dataType>
    <defaultValue>default Value</defaultValue>
  </allowedValueList>
```

```
        <allowedValue>Property Data1</allowedValue>
        Declarations for other allowed values added by UPnP vendor (if any) go here
    </allowedValueList>
</stateVariable>
<!--String type -->
<stateVariable sendEvents="yes" or "no">
    <name>VariableName</name>
    <dataType>string</dataType>
    <defaultValue>default Value</defaultValue>
</stateVariable>
<!-- 'Others' type -->
<stateVariable sendEvents="yes" or "no">
    <name>VariableName</name>
    <dataType>bin.hex</dataType>
    <defaultValue>default Value</defaultValue>
</stateVariable>
Declarations for other state variables added by UPnP vendor (if any) go here
</serviceStateTable>
</scpd>
```

6.3 Example XML Service Description (Air Conditioner)

This section shows an example of an XML Service Description for a virtual UPnP device for an air conditioner (EOJ = 0x013000).

Table 6.6 Example of Actual XML Service Description (Air Conditioner)

```
<scpd xmlns="urn:schemas-upnp-org:service-1-0">
  <specVersion>
    <major>1</major>
    <minor>0</minor>
  </specVersion>
  <actionList>
    <action>
      <name>SetOperationStatus</name>
      <argumentList>
        <argument>
          <name>NewOperationStatus</name>
          <direction>in</direction>
          <relatedStateVariable>OperationStatus</relatedStateVariable>
        </argument>
      </argumentList>
    </action>
    <action>
      <name>GetOperationStatus</name>
      <argumentList>
```

```
        <argument>
            <name>CurrentOperationStatus</name>
            <direction>out</direction>
            <relatedStateVariable>OperationStatus</relatedStateVariable>
        </argument>
    </argumentList>
</action>
<action>
    <name>GetProductCode</name>
    <argumentList>
        <argument>
            <name>CurrentProductCode</name>
            <direction>out</direction>
            <relatedStateVariable>ProductCode</relatedStateVariable>
        </argument>
    </argumentList>
</action>
<action>
    <name>SetOperationModeStatus</name>
    <argumentList>
        <argument>
            <name>NewOperationModeStatus</name>
            <direction>in</direction>
            <relatedStateVariable>OperationModeStatus</relatedStateVariable>
        </argument>
    </argumentList>
</action>
<action>
    <name>GetOperationModeStatus</name>
    <argumentList>
        <argument>
            <name>CurrentOperationModeStatus</name>
            <direction>out</direction>
            <relatedStateVariable>OperationModeStatus</relatedStateVariable>
        </argument>
    </argumentList>
</action>
<action>
    <name>WriteDesiredTemp</name>
    <argumentList>
        <argument>
            <name>NewDesiredTemp</name>
            <direction>in</direction>
            <relatedStateVariable>DesiredTemp</relatedStateVariable>
        </argument>
    </argumentList>
</action>
<action>
    <name>ReadDesiredTemp</name>
```

```
<argumentList>
  <argument>
    <name>CurrentDesiredTemp</name>
    <direction>out</direction>
    <relatedStateVariable>DesiredTemp</relatedStateVariable>
  </argument>
</argumentList>
</action>
<action>
  <name>SetWindVolumeLevel</name>
  <argumentList>
    <argument>
      <name>NewWindVolumeLevel</name>
      <direction>in</direction>
      <relatedStateVariable>WindVolumeLevel</relatedStateVariable>
    </argument>
  </argumentList>
</action>
<action>
  <name>GetWindVolumeLevel</name>
  <argumentList>
    <argument>
      <name>CurrentWindVolumeLevel</name>
      <direction>out</direction>
      <relatedStateVariable>WindVolumeLevel</relatedStateVariable>
    </argument>
  </argumentList>
</action>
</actionList>
<serviceStateTable>
  <stateVariable sendEvents="yes">
    <name>OperationStatus</name>
    <dataType>string</dataType>
    <allowedValueList>
      <allowedValue>ON</allowedValue>
      <allowedValue>OFF</allowedValue>
    </allowedValueList>
  </stateVariable>
  <stateVariable sendEvents="no">
    <name>ProductCode</name>
    <dataType>string</dataType>
  </stateVariable>
  <stateVariable sendEvents="yes">
    <name>OperationModeStatus</name>
    <dataType>string</dataType>
    <allowedValueList>
      <allowedValue>Auto</allowedValue>
      <allowedValue>Cooling</allowedValue>
      <allowedValue>Heating</allowedValue>
    </allowedValueList>
  </stateVariable>
</serviceStateTable>
```

```
        <allowedValue>Dehumidifying</allowedValue>
        <allowedValue>Blast</allowedValue>
        <allowedValue>Other</allowedValue>
    </allowedValueList>
</stateVariable>
<stateVariable sendEvents="yes">
    <name>DesiredTemp</name>
    <dataType>ui1</dataType>
    <allowedValueRange>
        <minimum>16</minimum>
        <maximum>30</maximum>
        <step>1</step>
    </allowedValueRange>
</stateVariable>
<stateVariable sendEvents="yes">
    <name>WindVolumeLevel</name>
    <dataType>string</dataType>
    <allowedValueList>
        <allowedValue>1</allowedValue>
        <allowedValue>2</allowedValue>
        <allowedValue>3</allowedValue>
        <allowedValue>4</allowedValue>
        <allowedValue>5</allowedValue>
        <allowedValue>6</allowedValue>
        <allowedValue>7</allowedValue>
        <allowedValue>8</allowedValue>
        <allowedValue>Auto</allowedValue>
    </allowedValueList>
</stateVariable>
</serviceStateTable>
</scpd>
```

Chapter 7 ECHONET Object-based Method

This chapter specifies the requirements regarding the operation of ECHONET Lite-UPnP gateways for the case where the ECHONET Object-based Method is used.

7.1 Concept

The implementation of the ECHONET Object-based Method is optional, while the implementation of the UPnP Device-based Method is compulsory.

In the ECHONET Object-based Method, ECHONET Lite-UPnP gateways provide services provided by UPnP devices as virtual ECHONET objects in an ECHONET Lite network. Such virtual ECHONET objects are hereinafter referred to as ECHONET objects.

ECHONET objects corresponding to UPnP devices in an ECHONET Lite network shall operate in accordance with the ECHONET Lite Specification and shall be treated in the same way as ordinary ECHONET objects.

Fig. 7.1 shows the system structure for the ECHONET Object-based Method.

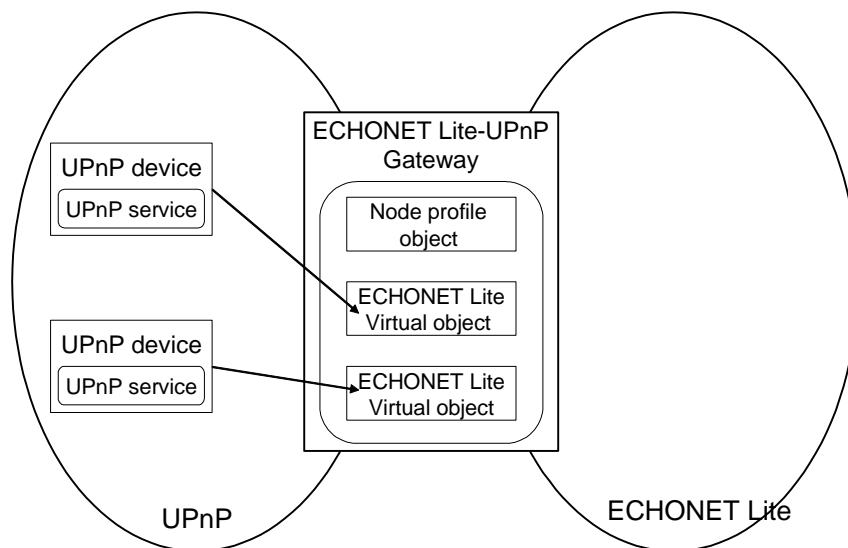

Fig. 7.1 System Structure for the Case where the ECHONET Object-based Method Is Used

Chapter 8 Processing for ECHONET Lite-UPnP Gateways for the ECHONET Object-based Method

This chapter specifies the requirements regarding the processing to be performed in the case where an ECHONET Lite-UPnP gateway operates as an ECHONET Lite device in the ECHONET Lite:

- Plug and play processing
- Control of UPnP devices from ECHONET objects

8.1 Plug and Play Processing

The following sections specify the requirements regarding the plug and play processing to be performed when an ECHONET Lite-UPnP gateway connects to a network and that to be performed when a UPnP device connects to a network. No requirement is specified regarding the plug and play processing to be performed when an ECHONET object which serves as a controller connects to a network, because the connection does not affect the operation of ECHONET Lite-UPnP gateways.

The ECHONET Lite-UPnP gateway-related processing to be performed when a UPnP device disconnects from a network is beyond the scope of the ECHONET Lite Specification.

8.1.1 Processing to be performed when an ECHONET Lite-UPnP gateway connects to a network

This section specifies the requirements regarding the ECHONET Lite-UPnP gateway-related processing to be performed when an ECHONET Lite-UPnP gateway connects to a network, as well as the sequence to be followed. **Fig. 8.1** shows the sequence. When an ECHONET Lite-UPnP gateway starts up, it shall multicast a “search” message in the UPnP network to confirm whether a UPnP device is present. If the ECHONET Lite-UPnP gateway receives a “response” message to the “search” message, it shall acquire the XML device and service descriptions and generate ECHONET device objects based on the acquired XML device description. The ECHONET Lite-UPnP gateway shall then amend the node profile object properties such that the newly generated ECHONET objects are counted in, and shall send a status change notification. The status change notification shall meet the ECHONET Lite Specification.

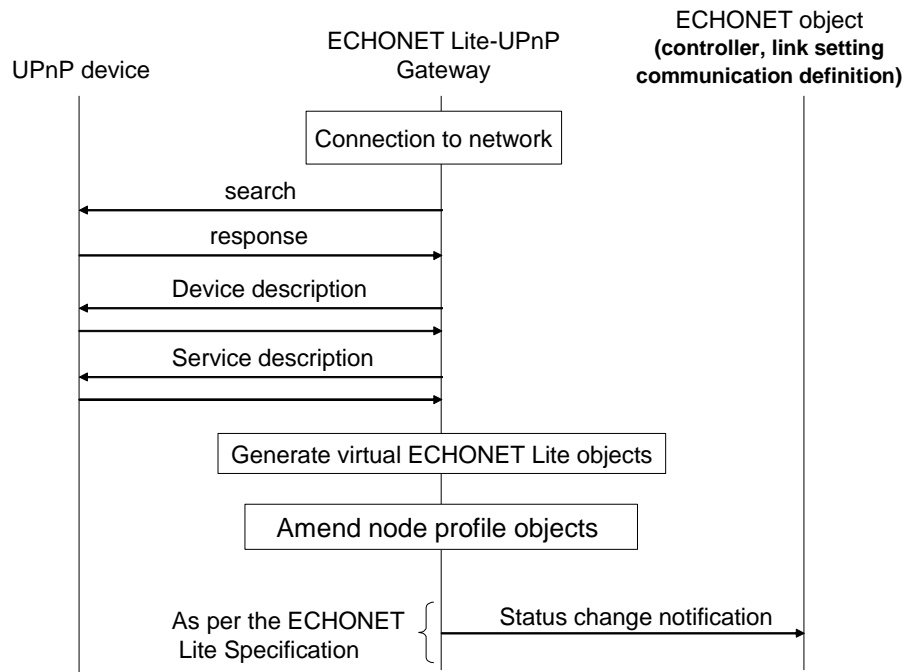

Fig. 8.1 Processing To Be Performed when an ECHONET Lite-UPnP Gateway Connects to a Network

8.1.2 Processing to be performed when a UPnP device connects to a network

This section specifies the requirements regarding the ECHONET Lite-UPnP gateway-related processing to be performed when a UPnP device connects to a network, as well as the sequence to be followed. **Fig. 8.2** shows the sequence.

If an ECHONET Lite-UPnP gateway receives an “advertise” message multicast by a UPnP device connecting to a network, the ECHONET Lite-UPnP gateway acquires the XML device and service descriptions and generates ECHONET objects based on the acquired XML device description. The ECHONET Lite-UPnP gateway shall then amend the node profile object properties such that the newly generated ECHONET objects are counted in, and shall send a status change notification. The status change notification shall meet the ECHONET Lite Specification.

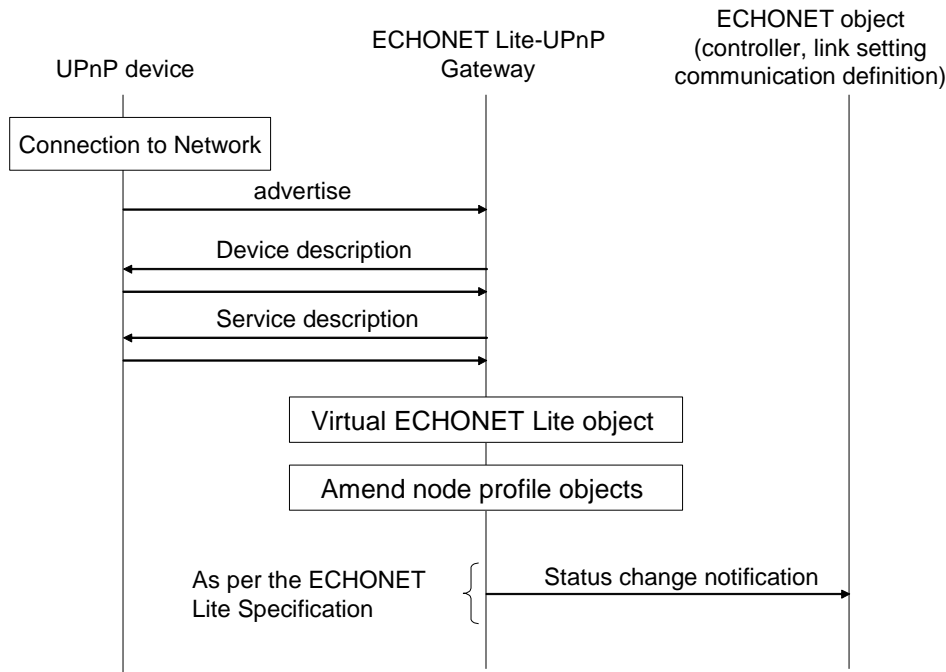

Fig. 8.2 Processing To Be Performed when a UPnP device Connects to a Network

8.2 Control of UPnP Devices from ECHONET Objects

8.2.1 Control of UPnP Devices

This section specifies the requirements regarding the ECHONET Lite-UPnP gateway-related processing to be performed when an ECHONET object (controller object, link setting communication definition object, etc.) controls a UPnP device via an ECHONET Lite-UPnP gateway, as well as the sequence to be followed. Fig. 8.3 shows the sequence for the operation of the ECHONET Lite-UPnP gateway.

If an ECHONET Lite-UPnP gateway receives a control request from an ECHONET object, the ECHONET Lite-UPnP gateway shall perform a conversion to the UPnP protocol data format and send an “action request” to the UPnP device. The ECHONET Lite-UPnP gateway shall then receive a “result” from the UPnP device. A control response shall be sent to the ECHONET object which is the sender of the control request only if the control request from the ECHONET object is a write message that requires a response.

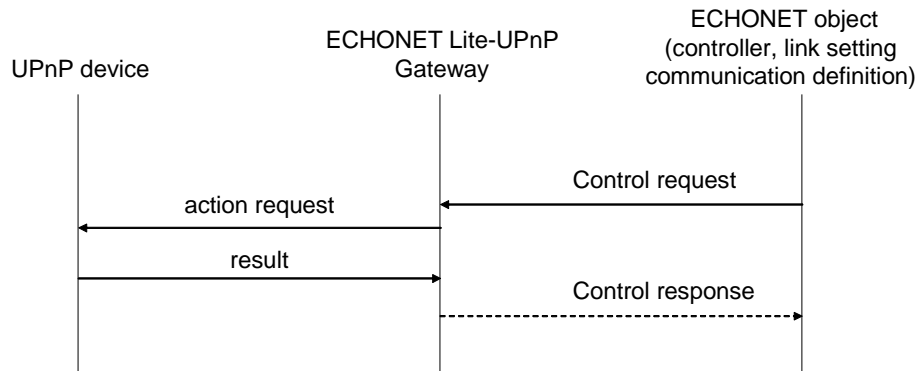

Fig. 8.3 UPnP Device Control Sequence

8.2.2 Referencing the statuses of UPnP devices

This section specifies the requirements regarding the ECHONET Lite-UPnP gateway-related processing to be performed when an ECHONET object (controller object, link setting communication definition object, etc.) references the status of a UPnP device via an ECHONET Lite-UPnP gateway, as well as the sequence to be followed.

Fig. 8.4 shows the sequence for the operation of the ECHONET Lite-UPnP gateway.

If an ECHONET Lite-UPnP gateway receives a status referencing request from an ECHONET object, the ECHONET Lite-UPnP gateway shall perform a conversion to the UPnP protocol data format and send an “action request” to the UPnP device. The ECHONET Lite-UPnP gateway shall then receive a “result” from the UPnP device. The ECHONET Lite-UPnP gateway shall send a status referencing response to the ECHONET object from which the status referencing request was sent.

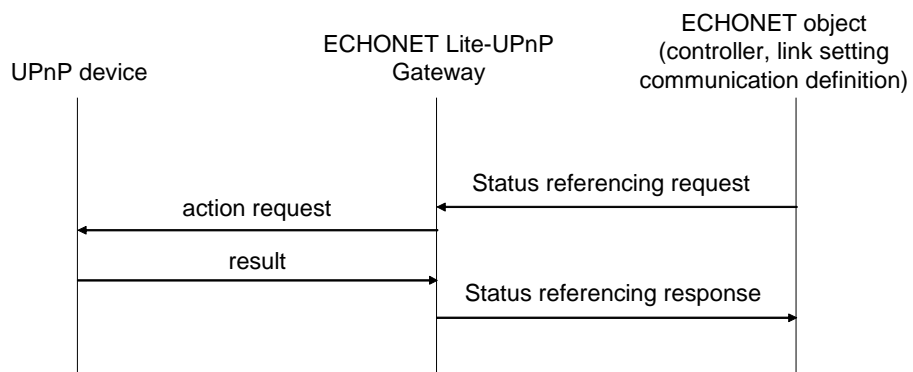

Fig. 8.4 UPnP Device Status Referencing Sequence