

APPENDIX
Detailed Requirements
for ECHONET Device objects

Release D

Contents

Chapter1 Outline of this document	1-1
Chapter2 Device Object Super Class Requirements	2-1
2. 1 “Operation status” property	2-4
2. 2 “Installation location” property	2-5
2. 3 “Standard version information” property	2-7
2. 4 “Fault status” property	2-7
2. 5 “Fault description” property.....	2-7
2. 6 “Manufacturer code” property	2-10
2. 7 “Business facility code” property	2-10
2. 8 “Product code” property.....	2-10
2. 9 “Production number” property.....	2-10
2. 10 “Production date” property	2-11
2. 11 “Property map” property	2-11
2. 12 “Identification number” property.....	2-12
2. 13 “Manufacturer’s fault code” property	2-13
2. 14 “Current limit setting” property.....	2-13
2. 15 “Power-saving operation setting” property.....	2-14
2. 16 “Remote control setting” property.....	2-14
2. 17 “Cumulative operating time” property.....	2-14
2. 18 “Current time setting” property	2-15
2. 19 “Current date setting” property.....	2-15
2. 20 “Measured instantaneous power consumption” property.....	2-15
2. 21 “Measured cumulative power consumption” property.....	2-15
2. 22 “Power limit setting” property	2-15
Chapter3 Detailed Requirements for Device Objects.....	3-1
3. 1 Sensor-related Device Class Group	3-1
3. 1. 1 Requirements for gas leak sensor class.....	3-3
3. 1. 2 Requirements for crime prevention sensor class.....	3-5
3. 1. 3 Requirements for emergency button class.....	3-7
3. 1. 4 Requirements for first-aid sensor class.....	3-8
3. 1. 5 Requirements for earthquake sensor class.....	3-10
3. 1. 6 Requirements for electric leak sensor class	3-12
3. 1. 7 Requirements for human detection sensor class	3-14
3. 1. 8 Requirements for visitor sensor class	3-15
3. 1. 9 Requirements for call sensor class.....	3-17
3. 1. 10 Requirements for condensation sensor class.....	3-19

3. 1. 11	Requirements for air pollution sensor class.....	3-21
3. 1. 12	Requirements for oxygen sensor class	3-23
3. 1. 13	Requirements for illuminance sensor class.....	3-24
3. 1. 14	Requirements for sound sensor class	3-26
3. 1. 15	Requirements for mailing sensor class.....	3-28
3. 1. 16	Requirements for weight sensor class.....	3-29
3. 1. 17	Requirements for temperature sensor class.....	3-30
3. 1. 18	Requirements for humidity sensor class.....	3-31
3. 1. 19	Requirements for rain sensor class.....	3-32
3. 1. 20	Requirements for water level sensor class.....	3-33
3. 1. 21	Requirements for bath water level sensor class	3-35
3. 1. 22	Requirements for bath heating status sensor class.....	3-37
3. 1. 23	Requirements for water leak sensor class	3-39
3. 1. 24	Requirements for water overflow sensor class	3-41
3. 1. 25	Requirements for fire sensor class.....	3-43
3. 1. 26	Requirements for cigarette smoke sensor class.....	3-45
3. 1. 27	Requirements for CO ₂ sensor class.....	3-47
3. 1. 28	Requirements for gas sensor class.....	3-48
3. 1. 29	Requirements for VOC sensor class	3-50
3. 1. 30	Requirements for differential pressure sensor class.....	3-52
3. 1. 31	Requirements for air speed sensor class	3-53
3. 1. 32	Requirements for odor sensor class	3-54
3. 1. 33	Requirements for flame sensor class	3-56
3. 1. 34	Requirements for electric energy sensor class	3-58
3. 1. 35	Requirements for current value sensor class.....	3-60
3. 1. 36	Requirements for water flow rate sensor class	3-62
3. 1. 37	Requirements for micromotion sensor class.....	3-63
3. 1. 38	Requirements for passage sensor class	3-65
3. 1. 39	Requirements for bed presence sensor class	3-67
3. 1. 40	Requirements for open/close sensor class	3-68
3. 1. 41	Requirements for activity amount sensor class	3-70
3. 1. 42	Requirements for human body location sensor.....	3-72
3. 1. 43	Requirements for snow sensor class.....	3-75
3. 2	Air Conditioner-related Device Class Group	3-77
3. 2. 1	Requirements for home air conditioner class.....	3-79
3. 2. 2	Requirements for ventilation fan class	3-103
3. 2. 3	Requirements for air conditioner ventilation fan class.....	3-104
3. 2. 4	Requirements for air cleaner class	3-107
3. 2. 5	Requirements for humidifier class	3-109
3. 2. 6	Requirements for electric heater class.....	3-112
3. 2. 7	Requirements for Fan heater class	3-116

3. 2. 8	Requirements for package-type commercial air conditioner (indoor unit) class.....	3-120
3. 2. 9	Requirements for package-type commercial air conditioner (outdoor unit) class	3-138
3. 3	Housing/Facilities-related Device Class Group.....	3-143
3. 3. 1	Requirements for electrically operated blind/shade class	3-146
3. 3. 2	Requirements for electrically operated shutter class	3-152
3. 3. 3	Requirements for electrically operated rain sliding door/shutter class.....	3-157
3. 3. 4	Requirements for electrically operated gate class	3-163
3. 3. 5	Requirements for electrically operated window class.....	3-168
3. 3. 6	Requirements for automatically operated entrance door/sliding door class.....	3-173
3. 3. 7	Requirements for sprinkler (for garden) class.....	3-178
3. 3. 8	Requirements for electric water heater class	3-181
3. 3. 9	Requirement for the electric toilet seat (warm-water washing toilet seat, heating toilet seat, etc.) class	3-191
3. 3. 10	Requirement for the electric lock class	3-195
3. 3. 11	Requirements for instantaneous water heater class	3-198
3. 3. 12	Requirements for bathroom heater and dryer class.....	3-206
3. 3. 13	Requirements for household solar power generation class	3-216
3. 3. 14	Requirement for cold or hot water heat source equipment class.....	3-220
3. 3. 15	Requirement for floor heater class	3-226
3. 3. 16	Requirements for fuel cell class.....	3-232
3. 3. 17	Requirements for storage battery class.....	3-237
3. 3. 18	Requirements for electric vehicle charger/discharger class.....	3-249
3. 3. 19	Requirements for engine cogeneration class.....	3-260
3. 3. 20	Requirements for watt-hour meter class.....	3-265
3. 3. 21	Requirements for water flowmeter class	3-267
3. 3. 22	Requirements for gas meter class	3-271
3. 3. 23	Requirements for LP gas meter class	3-273
3. 3. 24	Requirements for power distribution board metering class.....	3-279
3. 3. 25	Requirements for smart electric energy meter class.....	3-291
3. 3. 26	Requirements for smart gas meter class.....	3-306
3. 3. 27	Requirements for general lighting class.....	3-315
3. 3. 28	Requirements for buzzer class.....	3-325
3. 4	Cooking/Household-related Device Class Group.....	3-326
3. 4. 1	Requirements for electric hot water pot (Electric thermos).....	3-328
3. 4. 2	Requirements for refrigerator class	3-330
3. 4. 3	Requirements for combination microwave oven (electronic oven) class.....	3-343
3. 4. 4	Requirements for cooking heater class	3-359
3. 4. 5	Requirements for rice cooker class.....	3-365
3. 4. 6	Requirements for washing machine class.....	3-368
3. 4. 7	Requirements for clothes dryer class.....	3-371
3. 4. 8	Requirements for washer and dryer class.....	3-374

3. 5 Health-related Device Class Group	3-404
3. 5. 1 Requirements for weighing machine class.....	3-405
3. 6 Management/Operation-related Device Class Group.....	3-406
3. 6. 1 Requirements for switch class (supporting JEM-AV/HA terminals).....	3-407
3. 7 Audiovisual-related Device Class Group.....	3-408
3. 7. 1 Requirements for display class.....	3-409
3. 7. 2 Requirements for television class.....	3-415
Annex 1 Property Map Description Format	I

The specifications published by the ECHONET Consortium are established without regard to industrial property rights (e.g., patent and utility model rights). In no event will the ECHONET Consortium be responsible for industrial property rights to the contents of its specifications.

In no event will the publisher of this specification be liable to you for any damages arising out of use of this specification.

The original language of The ECHONET Specification is Japanese. The English version of the Specification was translated the Japanese version. Queries in the English version should be referred to the Japanese version.

Chapter1 Outline of this document

This Appendix describes detailed property configurations of the device objects of class groups (class group codes 0x00 to 0x05) corresponding to device objects, and device object super classes.

Each class corresponding to device objects is inherited from properties of the device object super class. Accordingly, the device mounting each class shall mount a property specified by each class of this Appendix and a property of the device object super class. For the basic specifications for device objects, refer to “Part 2 ECHONET Communication Middleware Specifications” and “Part 2 ECHONET Lite Communication Middleware Specifications.” Properties specified as array elements (SetM, GetM) cannot be installed in an ECHONET Lite device.

It is not necessary for the actual device to implement all functions which correspond to codes listed in the “Value range” of “Contents of property,” but the actual device should implement only those codes to hold as its function. See also the requirements for the “communication definition objects,” which are used to specify the behaviors of equipment objects in relation to communication, specified in “Part 2 ECHONET Communication Middleware Specifications.” For example, when it is necessary to totally or partly disable the controls on the main unit side (remote control, etc.), the “local control limit setting” communication definition class is used. The “communication definition objects” is supported only ECHONET. (ECHONET Lite is non-support.)

This document also defines properties that are now difficult to install in all devices but recommended from the perspective of service for installation in devices as “Conditionally Required.”

Each of the conditionally required properties of each class is differentiated in the property table for the class from the other types of properties by one of the symbols shown in Table 1-1, which is given in the “Mandatory” column of the relevant row. Each of the symbols shown in Table 1-1 represents application services that can be achieved by implementing the property in question.

Table 1-1 “Conditionally Required Property” Symbols and Corresponding Application Services

Application services name	Examples of services	Symbol
Mobile services	<ul style="list-style-type: none"> • Remote monitoring of the operation statuses of devices intended for indoor use • Remote control and remote locking of devices intended for indoor use • Remote monitoring of visitors and day-to-day activities of senior citizens 	Ⓜ
Energy services	<ul style="list-style-type: none"> • Monitoring of electricity consumptions and electricity bills • Coordinated power-saving operation of air conditioners, exhaust fans, lighting apparatuses and window shades • Contract-based electricity demand control 	ⓔ
Home amenity services	<ul style="list-style-type: none"> • Centralized control of window shades, exhaust fans and lighting apparatuses • Scheduled operation of devices intended for indoor use (preheating, precooling) 	Ⓜ _a
Home health-care services	<ul style="list-style-type: none"> • Health management services (hospitals, health adviser companies) • Life care services for senior citizens • Monitoring and control of home medical care equipment 	Ⓜ _h
Security services	<ul style="list-style-type: none"> • Fire prevention (monitoring to detect fires, gas leaks and electricity leaks) • Disaster prevention (detection of water leaks, measures to respond to earthquakes, prevention of freezing) • Crime prevention (visitor control, prevention of trespassing) 	Ⓢ
Remote appliance maintenance services	<ul style="list-style-type: none"> • Remote maintenance of devices intended for indoor use and remote diagnosis of such devices to detect failures • Remote consulting for the operation of devices intended for indoor use 	Ⓡ

This version of Appendix introduces the concept of “manufacturer-specific codes,” so that manufacturer-specific functions can be covered. Manufacturer-specific code values can only be assigned in relation to the codes specified as manufacturer-specific codes in the “Contents of property” column. Manufacturer-specific codes are codes that are outside the scope of the ECHONET Specification. Manufacturer-specific code values shall be defined by individual manufacturers, and the addition and deletion of and alterations to manufacturer-specific code values shall be done by individual manufacturers at their discretion. Whether to publish the assigned manufacturer-specific code values shall be determined by individual manufacturers.

Chapter2 Device Object Super Class Requirements

The device object super class properties are properties that are inherited to and implemented in each device object class. The device object super class requirements are as described below.

It is mandatory to implement the “operation status” (EPC=0x80) property in all device object classes as a “Get” access rule, that is, as a property that can be referenced by the other nodes. Similarly, it is mandatory to implement the “Status change announcement property map” (EPC=0x9D), “Fault status” (EPC=0x88), “Set property map” (EPC=0x9E) and “Get property map” (EPC=0x9F) properties as “Get” access rules, that is, as properties that can be referenced. The implementation of “SetM property map” and “GetM property map” is mandatory for ECHONET devices, but is not permitted for ECHONET Lite devices because it is not possible to implement array element properties in the case of ECHONET Lite devices.

Device object super class is defined using the 0x80 to 0x9F domain, which is the domain common to all classes. The domain common to all classes has been used to define “ON timer reservation setting” (0x90), “ON timer time setting” (0x91), “ON timer relative time setting” (0x92), “OFF timer reservation setting” (0x94), “OFF timer time setting” (0x95) and “OFF timer relative time setting” (0x96), although this is not a super class requirement. Explanations about the device objects in which these properties are implemented are provided in “Detailed Requirements for the Device Objects” in APPENDIX. Table 2-1 shows a list of the device object super class properties.

Table 2-1 List of Device Object Super Class Properties

Property name	E P C	Contents of property	Data size	Data size (Byte)	Access rule	Mandatory Note2	Announcement at status change	Remark
		Value range (decimal notation)						
Operation status	0x80	This property indicates the ON/OFF status.	unsigned char	1	Set	○	○	
		ON=0x30, OFF=0x31			Get			
Installation location	0x81	This property indicates the installation location	unsigned char	1 or 17	Set/Get	○ Note4	○	
		See “2.2 ‘Installation location’ property.”						
Standard version information	0x82	This property indicates the release number of the corresponding Appendix.	unsigned char×4	4	Get	○		
		First byte: Fixed at 0x00 (for future reserved). Second byte: Fixed at 0x00 (for future reserved). Third byte: Indicates the order of release in the ASCII format. Fourth byte: Fixed at 0x00 (for future reserved).						
		A number that allows each object to be uniquely identified.		9				

Identification number	0x83	<p>First byte: lower-layer communication ID field</p> <p>0x01–0xFD:</p> <p>This is a communication protocol used in the lower-layer communication and is set arbitrarily according to the protocol class in the case where unique number is assigned (not used in ECHONET Lite).</p> <p>0x11–0x1F: Power line Communication Protocol a and d systems</p> <p>0x31–0x3F: Low-Power Radio Communication Protocol</p> <p>0x41–0x4F: Extended HBS</p> <p>0x51–0x5F: IrDA</p> <p>0x61–0x6F: LonTalk</p> <p>0x71–0x7F: Bluetooth</p> <p>0x81–0x8F: Ethernet</p> <p>0x91–0x9F: IEEE802.11/11b</p> <p>0xA1: Power line Communication Protocol c systems</p> <p>0xB1: IPv6/Ethernet</p> <p>0xB2: IPv6/6LoWPAN</p> <p>0xFE: 2–17 bytes are defined by the manufacturer, and are set according to the type.</p> <p>0xFF: 2–9 bytes are defined when randomly generated protocol is used in the lower-layer communication.</p> <p>0x00: Identification number is not set.</p> <p>Second and succeeding bytes: unique number field</p>	unsigned char	or 17	Get			
Measured instantaneous power consumption	0x84	<p>This property indicates the instantaneous power consumption of the device in watts.</p>	unsigned short	2	Get			
		0x0000–0xFFFF(0–65533W)						
Measured cumulative power consumption	0x85	<p>This property indicates the cumulative power consumption of the device in increments of 0.001kWh.</p>	unsigned long	4	Get			
		0x00000000–0x3B9AC9FF (0–999,999.999kWh)						
Manufacturer's fault code	0x86	<p>This property indicates the manufacturer-defined fault code.</p>	unsigned char×5	Max 225	Get			
		<p>First byte: Indicates the data size of the fault code field.</p> <p>Second to fourth bytes: Manufacturer code</p> <p>Fifth and succeeding bytes: Field for manufacturer-defined fault code</p>						
Current limit setting	0x87	<p>This property indicates the current limit setting (0–100%).</p>	unsigned char	1	Set/Get			
		0x00–0x64 (=0–100%)						

Fault status	0x88	This property indicates whether a fault (e.g. a sensor trouble) has occurred or not.	unsigned char	1	Get	○	○	
		Fault occurred=0x41, No fault has occurred=0x42						
Fault description	0x89	Describes the fault.	unsigned short	2	Get			
		See "2.5 'Fault Description' Property."						
Manufacturer code	0x8A	3-byte manufacturer code	unsigned char×3	3	Get	○		
		(Defined by the ECHONET Consortium.)						
Business facility code	0x8B	3-byte business facility code	unsigned char×3	3	Get			
		(Defined by each manufacturer.)						
Product code	0x8C	Identifies the product using ASCII code.	unsigned char×12	12	Get			
		(Defined by each manufacturer.)						
Production number	0x8D	This property indicates the production number using ASCII code.	unsigned char×12	12	Get			
		(Defined by each manufacturer.)						
Production date	0x8E	4-byte production date code	unsigned char×4	4	Get			
		This property indicates the production date in the YYMD format (1 character = 1 byte). YY: Year (e.g. 1999=0x07CF) M: Month (e.g. December=0x0C) D: Day (e.g. 20th=0x14)						
Power-saving operation setting	0x8F	This property indicates whether the device is operating in power-saving mode.	unsigned char	1	Set/Get			
		Operating in power-saving mode =0x41 Operating in normal operation mode =0x42						
Remote control setting	0x93	This property indicates whether remote control is through a public network or not.	unsigned char	1	Set/Get			
		Not through a public network =0x41 Through a public network =0x42						
Current time setting	0x97	Current time (HH: MM format)	unsigned char ×2	2	Set/Get			
		0x00-0x17: 0x00-0x3B (=0-23): (=0-59)						
Current date setting	0x98	Current date (YYYY: MM: DD format)	unsigned char ×4	4	Set/Get			
		1-0x270F: 1-0x0C: 1-0x1F (=1-9999): (=1-12): (=1-31)						
Power limit setting	0x99	This property indicates the power limit setting in watts.	unsigned short	2	Set/Get			
		0x0000-0xFFFF(0-65535W)						

Cumulative operating time	0x9A	This property indicates the cumulative number of days, hours, minutes or seconds for which the device has operated, using 1 byte for the unit and 4 bytes for the time.	unsigned char + unsigned long	1+4 bytes	Get			
		First byte: Indicates the unit. Second: 0x41; Minute: 0x42; Hour: 0x43; Day:0x44 Second to fifth bytes: Indicates the elapsed time in the unit specified by the first byte. 0x00000000–0xFFFFFFFF (0–4294967295)						
SetM property map	0x9B	See Annex 1.	unsigned char× (MAX17)	Max. 17	Get	○ Note3		
GetM property map	0x9C	See Annex 1	unsigned char× (MAX17)	Max. 17	Get	○ Note3		
Status change announcement property map	0x9D	See Annex 1.	unsigned char× (MAX17)	Max. 17	Get	○		
Set property map	0x9E	See Annex 1.	unsigned char× (MAX17)	Max. 17	Get	○		
Get property map	0x9F	See Annex 1.	unsigned char× (MAX17)	Max. 17	Get	○		

Note1: In the case of a transmission-only device as defined in ECHONET Lite, the implementation of the properties specified as mandatory properties in the table is not mandatory. In addition, announcement at status change for the “Operation status” property is not mandatory. For the handling of transmission-only devices, see Chapter 3 of “Part 5 ECHONET Lite System Design Guidelines.”

Note2: The ○ marks in the “Announcement at status change” column indicate that the processing is mandatory when the property is implemented.

Note3: GetM property map and SetM property map may not be implemented in ECHONET Lite devices.

Note4: The size of 17 bytes is optional. See the section of 2.2 “Installation location” property for more information.

2. 1 “Operation status” property

The “Operation status” property of the device object super class indicates whether the functions specific to each class are operating in the actual device (ON) or not (OFF). In the case of a node in which a device object class is implemented and the functions

specific to that class start operating upon startup of the node, this property may be implemented with the value fixed at 0x30. (However, the operation status of the communications function of the node shall be indicated in the “Operation status” property of the node profile object.)

2. 2 “Installation location” property

The “Installation location” property indicates the location at which the device has been installed in the form of 1-byte bitmap information. This property is a rewritable mandatory property. When the value is changed, the new value must be broadcast throughout the domain.

The 8 bits of the “Installation location” property are assigned a free definition designation bit, an installation location code and a location number. In the case where all the bits are 0, a special code that indicates that the installation location has not been specified is used. In the case where all the bits are 1, a special code that indicates that the installation location is indefinite is used.

The information contained in each of the bits is as described below. Table 2-2 shows the relationships between the installation location type, free definition designation bit, installation location code and location number.

- Free definition designation bit (b7)

This is comprised of a single bit, b7. When b7 is 1, the installation location code and location number can be freely defined.

When b7 is 0, the installation location code and location number indicate the installation location of the device according to the rules specified in Table 2-2.

- Installation location code (b3 to b6)

This code is comprised of the 4 bits from b3 to b6. When b7 is 1, this code can be freely defined.

When b7 is 0, this code indicates the type of the installation location of the device according to the rules specified in Table 2-2.

- Location number (b0 to b2)

This number is comprised of the 3 bits from b0 to b2. When b7 is 1, this number can be freely defined. When b7 is 0, this number is used to distinguish a space of a given type from another space of the same type. For example, when there are two lavatories, the lavatory on the first floor can be distinguished from the lavatory on the second floor by assigning 001b as the location number for the former and 010b as the location number for the latter.

When b7 is 0, the value 000b for the location number indicates that the “Installation location” property has been initialized on the assumption that the device will be installed at the installation location specified by the installation location code. This situation is herein expressed as the “location number not specified” situation.

In the case where the “Installation location” property has been initialized without making an assumption about the type of the installation location for the device, the setting must be set to 0x00 (the “installation location not specified” code). When it is inappropriate to specify a specific location type as the installation location type for the device, the “Installation location” property setting must be set to 0xFF (the “installation location indefinite” code).

When the installation location code 0x01 is set, the next 16 bytes indicate the latitude, longitude, and altitude of the location where the equipment is installed. The total number of bytes is 17. Of the 16 bytes, excluding the installation location code, if the higher-order 8 bytes are 0x00, 0x00, 0x1B, 0x00, 0x00, 0x00, 0x00, and 0x03, the lower-order 8 bytes shall follow the location information codes specified by the Geospatial Information Authority of Japan. The position information definition of the installation location code 0x01 is optional.

The values 0x02 to 0x07 are reserved for future use.

Table 2-2 Installation Location (Space) Types and the Bit Values Assigned to Them

Installation location type	MSB					LSB			
	Free definition designation bit	Installation location code					Location number		
	b7	b6	b5	b4	b3	b2	b1	b0	
Living room	0	0	0	0	1	“000b”-“111b” (“000b” indicates that the location number has not been specified.)			
Dining room	0	0	0	1	0				
Kitchen	0	0	0	1	1				
Bathroom	0	0	1	0	0				
Lavatory	0	0	1	0	1				
Washroom/changing room	0	0	1	1	0				
Passageway	0	0	1	1	1				
Room	0	1	0	0	0				
Stairway	0	1	0	0	1				
Front door	0	1	0	1	0				
Storeroom	0	1	0	1	1				
Garden/perimeter	0	1	1	0	0				
Garage	0	1	1	0	1				
Veranda/balcony	0	1	1	1	0				
Others	0	1	1	1	1				
Free definition ^{*Note}	1	“0000000b”-“1111110b”							
Installation location not specified	0	0	0	0	0	0	0	0	
Installation location indefinite	1	1	1	1	1	1	1	1	

Position information	0	0	0	0	0	0	0	1
for future reserved	"00000010b"- "00000111b"							

Note: "Free definition" means that the installation location code and location number can be freely defined for the use of the device in a store or medium- or small-sized building.

2. 3 "Standard version information" property

The "Standard version information" property indicates the release order of the APPENDIX as a one-byte ASCII code.

The first and second bytes are fixed at 0x00 in this version, reserved for future expansion. The third byte indicates the order of release.

And, in APPENDIX Release B, the first and second bytes shall be 0x00(0), the third byte 0x42(B), and the fourth byte 0x00(0).

2. 4 "Fault status" property

The "Fault status" property of the device object super class indicates whether a fault has occurred in the actual device. This property shall be set to 0x41 when there is a fault and 0x42 when there is no fault.

2. 5 "Fault description" property

The "Fault description" property shall be assigned fault description code values as specified in Table 2-3. A "recoverable fault" as defined in the table is a fault which is currently inhibiting the proper operation of the device or a function of the device but whose cause can be removed by a user action. A "fault that requires repair" as defined in the table is a fault which is currently inhibiting the proper operation of the device or a function of the device and whose cause cannot be removed without repair work by a specialist.

The lower-order byte of the fault description code shall indicate the general fault classification and the higher-order byte of the fault description code shall indicate the detailed fault classification. The detailed fault classification for recoverable faults will be determined in the future for each class. In the case where recoverable faults or faults that require repair are to be identified only with the general fault classification without using the detailed fault classification, the higher-order byte of the fault description code shall be set to 0x00.

(1) Lower-order byte of the fault description code

The lower-order byte of the fault description code provides an overview of the fault in the form of general fault classification.

The value of the lower-order byte of the fault description code shall be 0x00 when no fault has occurred in the device.

The lower-order byte of the fault description code shall be set to a value between 0x01 and 0x09 when a recoverable fault (i.e. a fault that can be recovered from by a user action) occurs in the device, according to the value assignment rules described below. The general fault classification for recoverable faults is based on the type of user action required to recover from the fault. 0x01 indicates that a fault has occurred which can be recovered from by restarting the device by turning off the power and turning it on again. 0x02 indicates that a fault has occurred which can be recovered from by restarting the device by performing a reset operation. 0x03 indicates that a fault has occurred which can be recovered from by changing the way the device is mounted or opening/closing a lid or door. 0x04 indicates that a fault has occurred which can be recovered from by supplying fuel, water, air, etc. 0x05 indicates that a fault has occurred which can be recovered from by cleaning the device. 0x06 indicates that a fault has occurred which can be recovered from by changing the battery or cell. 0x09 can be freely defined by the user. 0x07 and 0x08 are reserved for future revisions to add other types of recoverable faults.

The lower-order byte of the fault description code shall be set to a value between 0x0A and 0x6E when a fault that requires repair occurs in the device, according to the value assignment rules described below. The general fault classification for faults that require repair is based on the location of the fault. 0x0A to 0x13 indicate that a safety device has tripped. 0x14 to 0x1D indicate that a fault has occurred in the user interface. 0x1E to 0x3B indicate that a fault has occurred in the sensor system. 0x3C to 0x59 indicate that a fault has occurred in an actuator etc. 0x5A to 0x6E indicate that a fault has occurred in a control circuit board.

(2) Higher-order byte of the fault description code

The higher-order byte of the fault description code provides detailed information on the fault in the form of detailed fault classification for each general fault classification category.

When the value of the lower-order byte of the fault description code is 0x00 (no fault), the value of the higher-order byte of the fault description code must be 0x00. 0x04 to 0xFF are for future reserved.

When the value of the lower-order byte of the fault description code is a value between 0x01 and 0x06, the higher-order byte of the fault description code can take the value 0x00 or a value between 0x04 and 0xFF. The higher-order byte of the fault description code shall be set at 0x00 in the case where faults are to be identified only with the general fault classification without using the detailed fault classification. 0x04 to 0xFF are reserved for future class-specific detailed fault classification.

When the value of the lower-order byte of the fault description code is 0x07 or 0x08, the higher-order byte of the fault description code can take the value 0x00 or a value between 0x04 and 0xFF. All of these values are for future reserved.

When the value of the lower-order byte of the fault description code is 0x09, the

higher-order byte of the fault description code can take the value 0x00 or a value between 0x04 and 0xFF. All of these values can be freely defined by the user.

When the value of the lower-order byte of the fault description code is a value between 0x0A and 0x6E, the higher-order byte of the fault description code can take the value 0x00 or a value between 0x04 and 0xFF. The higher-order byte of the fault description code shall be set at 0x00 in the case where faults are to be identified only with the general fault classification without using the detailed fault classification. The values 0x04 to 0xFF can be freely defined by the user.

The values between 0x006F and 0x03E8, which are values for combinations of higher- and lower-order bytes of the fault description code, are values that can be freely defined by the user for faults that require repair.

The value 0x03FF, which is a value for combinations of higher- and lower-order bytes of the fault description code, indicates that a fault has occurred but the recovery method or fault location cannot be determined.

The values between 0x03E9 and 0x03FE, which are values for combinations of higher- and lower-order bytes of the fault description code, are for future reserved.

Table 2-3 Fault Description Code Values

General fault classification		Fault description code (0x**%)	
		Fault description code Lower-order byte (%)	Fault description code Higher-order byte (**)
No fault		0x00	0x00: No fault 0x04-0xFF : for future reserved
Recoverable faults	Faults that can be recovered from by turning off the power switch and turning it on again or withdrawing and re-inserting the power plug.	0x01	0x00: Faults are to be identified only with the general fault classification without using the detailed fault classification. 0x04-0xFF : for future reserved
	Faults that can be recovered from by pressing the reset button.	0x02	
	Faults that can be recovered from by changing the way the device is mounted or opening/closing a lid or door.	0x03	
	Faults that can be recovered from by supplying fuel, water, air, etc.	0x04	
	Faults that can be recovered from by cleaning the device (filter etc.)	0x05	
	Faults that can be recovered from by changing the battery or cell.	0x06	

	for future reserved	0x07-0x08	0x00, 0x04-0xFF
	User-definable domain	0x09	0x00, 0x04-0xFF
Faults that require repair	Abnormal event or the tripping of a safety device	0x0a-0x13	0x00: Faults are to be identified only with the general fault classification without using the detailed fault classification. 0x04-0xFF : user-definable
	Fault in a switch	0x14-0x1D	
	Fault in the sensor system	0x1E-0x3B	
	Fault in a component such as an actuator	0x3C-0x59	
	Fault in a control circuit board	0x5A-0x6E	
	User-definable domain	0x006F-0x03E8	
A fault has occurred but the recovery method or fault location cannot be determined.		0x03FF	
for future reserved		0x03E9-0x03FE、 0x**6F-0x**FF (**: 04-FF)	

2. 6 “Manufacturer code” property

The “Manufacturer code” property identifies the manufacturer using a 3-byte code. Each ECHONET Consortium member is assigned a unique “Manufacturer code” property value by the Consortium.

2. 7 “Business facility code” property

The “Business facility code” property identifies the relevant business facility of the manufacturer using a 3-byte code. “Business facility code” property values are not defined by the ECHONET Consortium; they are defined by each manufacturer.

2. 8 “Product code” property

The “Product code” property identifies the relevant product of the manufacturer using a 12-byte ASCII code. “Product code” property values are not defined by the ECHONET Consortium; they are defined by each manufacturer. When the “Product code” property value is less than 12 bytes, the product code shall be left-justified in the data area and the remainder of the data area shall be padded with NULLs or spaces.

2. 9 “Production number” property

The “Production number” property indicates the production number of the relevant product of the manufacturer using a 12-byte ASCII code. “Production number” property values are not defined by the ECHONET Consortium; they are defined by each manufacturer. When the “Production number” property value is less than 12 bytes, the production number shall be left-justified in the data area and the remainder of the data area shall be padded with NULLs or spaces.

2. 10 “Production date” property

The “Production date” property indicates the production date of the relevant product of the manufacturer using a 4-byte code. Two of the 4 bytes are used to indicate the year of production. The remaining 2 bytes are used to indicate the month of production and the day of production, with one byte used for each.

2. 11 “Property map” property

The device object super class defines 3 “property maps,” which provide information on the services that can be provided by the individual properties published by objects.

Of these, “Set property map” and “Get property map” provide information as to what access rules the individual properties published by the implemented objects support in terms of individual product specifications.

“Status change announcement property map” indicates domain broadcast in ECHONET and general broadcast in ECHONET Lite in case of a property value change.

The formats of these maps are as shown in Annex 1. When there is no property to list in a map, the number of properties shall be set to “0” and the second and succeeding bytes shall be left blank.

The definitions of the individual property maps are as follows:

(1)Set property map

This is the property map that lists the properties which support the “Set” access rule. For array properties for which batch writing is to be permitted, the EPC values must be registered on the Set property map.

(2)Get property map

This is the property map that lists the properties which support the “Get” access rule. For array properties for which batch reading is to be permitted, the EPC values must be registered on the Get property map.

(3)SetM property map

This is the property map that lists the properties which support the “SetM” access rule. For array properties for which batch writing is to be permitted, the EPC values must be registered on the SetM property map. ECHONET Lite devices cannot implement the SetM property map because it is not possible to define array properties.

(4)GetM property map

This is the property map that lists the properties which support the “GetM” access rule. For array properties for which batch reading is to be permitted, the EPC values

must be registered on the GetM property map. ECHONET Lite devices cannot implement the GetM property map because it is not possible to define array properties.

(5) Status change announcement property map

This is the property map that lists the properties that have been so set that an intra-domain broadcast is performed in ECHONET and that broadcast is performed in ECHONET Lite upon a property value change. These properties include those which are supported in individual product specifications and are specified to require domain broadcasting or general broadcasting in the “Announcement at status change” column in the ECHONET and ECHONET Lite Specifications, and as well as properties that support “announcement at status change” as part of the product specifications independent of the ECHONET and ECHONET Lite Specifications. A property that is published in a property map as a property capable of supporting the access rule associated with the map must support that access rule. For properties that are not published in a property map as properties capable of supporting the access rule associated with the map, whether to support that access rule shall be device implementation-dependent.

2. 12 “Identification number” property

Definitions in ECHONET and ECHONET Lite are as follows:

- ECHONET definition

This property indicates a number that allows each node to be uniquely identified in the domain. The property indicates a lower-layer communication software ID field which stores IDs defined for each lower-layer communication software class and a unique number field that stores a unique identification number that is assigned to each product using a specified method for each lower-layer communication software program. The definition of this unique number is given in the specifications for lower-layer communication software programs in Part III. (However, Version 3.00 and later versions of the ECHONET Specifications define this unique number for IP/Bluetooth-dependent lower-layer communication software and IP/Ethernet/IEEE802.3 dependent lower-layer communication software.)

This unique number indicates the hardware address. If the hardware address is less than 8 bytes, it shall be stored in the unique number field from the highest-order byte and the remaining bytes shall be padded with 0.

Each ECHONET node must have at least one device object, but the node identification number property value must be the same as the value of the node identification number property held by the device object.

- ECHONET Lite definition

This property indicates a number that allows each device object to be uniquely identified in the domain. As ECHONET Lite does not define lower-layer communication protocol classes, it only considers 0xFE, 0xFF, and 0x00 as protocol classes of lower-layer communication.

Manufacturer's specific code (0xFE) consists of a manufacturer code field to store the code of each manufacturer and a field defined by each manufacturer.

The first to third bytes indicate a 3-byte manufacturer code specified by the ECHONET Consortium.

Byte 4 and later stores the unique ID of each vendor. Each vendor shall ensure that the codes will not overlap.

Manufacturer code (3Byte)	Unique ID field (unique identification number specified by the manufacturer) (13Byte)
---------------------------------	---

2. 13 “Manufacturer’s fault code” property

This property identifies the faults that have occurred in the device using unique fault codes defined by the manufacturer.

The first byte indicates the data size of the fault code field.

The second to fourth bytes indicates the 3-byte manufacturer code assigned to the manufacturer in question by the ECHONET Consortium.

The fifth and succeeding bytes (i.e. the fault code field) contains the unique fault code defined by the manufacturer in question.

In the case where this property is implemented, the implementation of the “Fault description” property is mandatory.

Data size of the fault code field (1Byte)	Manufactur er code (3Byte)	Fault code field (unique fault code defined by the manufacturer) (Max221Byte)
---	----------------------------------	---

2. 14 “Current limit setting” property

The “Current limit setting” property contains the setting for the maximum consumable current (i.e. current limit setting). The value range for this property is from 0 to 100 (from 0x00 to 0x64), and the unit is %. The maximum consumable current at any given moment for the device associated with the object in question is the maximum current specified for that device times the rate specified by the value contained in this property at that moment. When the value of this property is 100, no current limit is imposed. In the case where it is not possible to limit the current consumption using the value specified by

this property, the current consumption shall be limited using a value that is closest to and lower than the value specified by this property. A read value shall be one set in the equipment.

2. 15 “Power-saving operation setting” property

The “Power-saving operation setting” property contains the status as to whether the device associated with the object in question is operating in power-saving mode. When the value contained is 0x41, the device operates in power-saving mode. When the value contained is 0x42, the device operates in normal operation mode (non-power-saving mode).

2. 16 "Remote control setting" property

This property indicates by one byte whether remote control is through a public network or not. The value is 0x41 for control not through a public network and 0x42 for control through a public network.

For control through a public network, several properties including this property are stored in one message and the message is sent as a control request. When the message is sent, this property shall always be attached to the first property (EDT=0x42: control through a public network).

A control request message refers to a property value write request (no response required), property value write request (response required), or a property value write & read request.

For example, when an air conditioner is set to cooling mode by operation control through a public network, this property shall be set to the first property and sent by a single control request message in order of the "Remote control setting" property and the "Operation mode setting" property.

When a control request message is sent by using this property, the minimum value of the processing target property counter (OPC) shall be 2.

For control not through a public network, this property is not given but a control request message shall be sent. For example, when an air conditioner is set to cooling mode not through a public network, only the "Operation mode setting" property shall be sent as a control request message without this property.

When the property status is control through a public network (EDT=0x42) but there is control from a dedicated controller, direct control from the main unit, or control not through a public network, change the status to control not through a public network (EDT=0x41).

2. 17 “Cumulative operating time” property

The “Cumulative operating time” property indicates the cumulative operating time.

The first byte indicates the unit for the cumulative operating time. The values that can be used for the first byte are 0x41 (seconds), 0x42 (minutes), 0x43 (hours) and 0x44 (days). The second to fifth bytes are treated as one piece of unsigned long data which indicates the cumulative operating time in the unit specified by the first byte. The value range for the cumulative operating time (second to fifth bytes) shall be from 0x00000000 to 0xFFFFFFFFE (from 0 to 4294967294). 0xFFFFFFFF shall be used as the overflow code. The operating states that are to be counted in when counting up the operating periods and the conditions for starting and stopping the counting shall be device-dependent and no requirement is specified for these.

2. 18 “Current time setting” property

This property indicates the current local time using a value between 0x00 and 0x17 (0 and 23) for the hour and a value between 0x00 and 0x3B (0 and 59) for the minute.

The first byte of the property value indicates the hour and the second byte indicates the minute.

2. 19 “Current date setting” property

This property indicates the current date using a value between 0x0001 and 0x270F (1 and 9999) for the year, a value between 0x01 and 0x0C (1 and 12) for the month and a value between 0x01 and 0x1F (1 and 31) for the day.

The first and second bytes are treated as one piece of unsigned short data which indicates the year (2 bytes). The third byte indicates the month (1 byte) and the fourth byte indicates the day (1 byte).

2. 20 “Measured instantaneous power consumption” property

This property indicates the instantaneous power consumption of device in watts. The value range for this property is from 0x0000 to 0xFFFFD. When the property value of the actual device is higher than the upper bound of the value range, 0xFFFF (overflow code) shall be used. When the property value of the actual device is lower than the lower bound of the value range, 0xFFFFE (underflow code) shall be used.

2. 21 “Measured cumulative power consumption” property

This property indicates the cumulative power consumption of device in increments of 0.001kW. The value range for this property is from 0x00000000 to 0x3B9AC9FF (from 0 to 999,999.999kWh). When a measured cumulative power consumption overflow occurs, the counting shall restart from 0x00000000.

2. 22 “Power limit setting” property

This property contains the setting for the maximum consumable power (i.e. power limit

setting). The value range for this property is from 0 to 65535 (from 0x0000 to 0xFFFF), and the unit is watt. In the case where it is not possible to limit the power consumption using the value specified by this property, the power consumption shall be limited using a value that is closest to and lower than the value specified by this property. A read value shall be one set in the equipment.

Chapter3 Detailed Requirements for Device Objects

3. 1 Sensor-related Device Class Group

This section specifies detailed codes and properties of each ECHONET object belonging to the sensor-related device class group (class group code X1 = 0x00). Table 3-1 shows a list of classes specified in detail in this section. “Mandatory” means that the device mounting each class must mount a combination of its property and service.

Table 3-1 List of Objects of Sensor-related Device Class Group (1/2)

Group code	Class code	Class name	Whether or not detailed requirements are provided	Remarks
0x00	0x00	For future reserved		
	0x01	Gas leak sensor	○	
	0x02	Crime prevention sensor	○	
	0x03	Emergency button	○	
	0x04	First-aid sensor	○	
	0x05	Earthquake sensor	○	
	0x06	Electric leak sensor	○	
	0x07	Human detection sensor	○	
	0x08	Visitor sensor	○	
	0x09	Call sensor	○	
	0x0A	Condensation sensor	○	
	0x0B	Air pollution sensor	○	
	0x0C	Oxygen sensor	○	
	0x0D	Illuminance sensor	○	
	0x0E	Sound sensor	○	
	0x0F	Mailing sensor	○	
	0x10	Weight sensor	○	
	0x11	Temperature sensor	○	
	0x12	Humidity sensor	○	
	0x13	Rain sensor	○	
	0x14	Water level sensor	○	
	0x15	Bath water level sensor	○	
	0x16	Bath heating status sensor	○	
	0x17	Water leak sensor	○	
0x18	Water overflow sensor	○		
0x19	Fire sensor	○		
0x1A	Cigarette smoke sensor	○		
0x1B	CO ₂ sensor	○		
0x1C	Gas sensor	○		

List of Objects of Sensor-related Device Class Group (2/2)

Group code	Class code	Class name	Whether or not detailed requirements are provided	Remarks
0x00	0x1D	VOC sensor	○	
	0x1E	Differential pressure sensor	○	
	0x1F	Air speed sensor	○	
	0x20	Odor sensor	○	
	0x21	Flame sensor	○	
	0x22	Electric energy sensor	○	
	0x23	Current value sensor	○	
	0x24	Daylight sensor		
	0x25	Water flow rate sensor	○	
	0x26	Micromotion sensor	○	
	0x27	Passage sensor	○	
	0x28	Bed presence sensor	○	
	0x29	Open/close sensor	○	
	0x2A	Activity amount sensor	○	
	0x2B	Human body location sensor	○	
	0x2C	Snow sensor	○	
	0x2D to 0xFF	For future reserved		

Note: ○ indicates a detail is explained including a property structure in APPENDIX.

3. 1. 1 Requirements for gas leak sensor class

Class group code : 0x00

Class code : 0x01

Instance code : 0x01–0x7F (0x00: All-instance specification code)

Property name	EPC	Contents of property	Data type	Data Size	Unit	Access rule	Mandatory	Announcement at status change	Remark
		Value range (decimal notation)							
Operation status	0x80	This property indicates the ON/OFF status.	unsigned char	1 byte	—	Set		○	
		ON=0x30, OFF=0x31				Get			
Detection threshold level	0xB0	Specifies detection threshold level in 8 steps.	unsigned char	1 byte	—	Set/Get			
		0x31–0x38							
Gas leak occurrence status	0xB1	This property indicates gas leak occurrence status.	unsigned char	1 byte	—	Get	○	○	
		Gas leak occurrence status found = 0x41 Gas leak occurrence status not found = 0x42							
Gas leak occurrence status resetting	0xBF	Resets gas leak occurrence status by setting 0x00.	unsigned char	1 byte	—	Set			
		Reset = 0x00							

Note: In the “Announcement at status change” column, ○ denotes mandatory processing when the property is implemented.

(1) Operation status (inherited from the device object super class property)

This property indicates whether the function native to this class is operating or not (ON/OFF). In the node mounting this class, if the function of this class is started concurrently with the start of node operation, this property may be implemented at a fixed value of 0x30 (Operation status ON).

(2) Detection threshold level

Sets the threshold value that causes EPC = 0xB1 “Gas leak occurrence status” to be set to “Found” (8-step). The minimum value is 0x31 and the maximum value is 0x38. No concrete value is specified for each level. If the detection threshold of the actual device is higher or lower than the 8-step range, the property of the actual device shall be assigned to the property value of the 8 steps specified in this property.

(3) Gas leak occurrence status

This property indicates whether a gas leak occurrence status is found or not. When EPC = 0xB0 “Detection threshold level” is implemented, this property is set to “Gas leak occurrence status found” if the threshold set by the detection threshold level is

exceeded. When this property is set to “Gas leak occurrence status found” = 0x41, it shall be announced periodically. This property shall be set to “Gas leak occurrence status not found” = 0x42 by resetting the main body or by EPC = 0xBF “Gas leak occurrence status resetting”.

(4) Gas leak occurrence status resetting

Resets EPC = 0xB1 “Gas leak occurrence status” by setting 0x00.

3. 1. 2 Requirements for crime prevention sensor class

Class group code : 0x00

Class code : 0x02

Instance code : 0x01–0x7F (0x00: All-instance specification code)

Property name	EPC	Contents of property	Data type	Data size	Unit	Access rule	Mandatory	Announcement at status change	Remark
		Value range (decimal notation)							
Operation status	0x80	This property indicates the ON/OFF status.	unsigned char	1 byte	—	Set		○	
		ON=0x30, OFF=0x31				Get			
Detection threshold level	0xB0	Specifies detection threshold level (8-step).	unsigned char	1 byte	—	Set/Get			
		0x31–0x38							
Invasion occurrence status	0xB1	This property indicates invasion occurrence status.	unsigned char	1 byte	—	Get	○	○	
		Invasion occurrence status found = 0x41 Invasion occurrence status not found = 0x42							
Invasion occurrence status resetting	0xBF	Resets invasion occurrence status by setting 0x00.	unsigned char	1 byte	—	Set			
		Reset = 0x00							

Note: In the “Announcement at status change” column, ○ denotes mandatory processing when the property is implemented.

(1) Operation status (inherited from the device object super class property)

This property indicates whether the function native to this class is operating or not (ON/OFF). In the node mounting this class, if the function of this class is started concurrently with the start of node operation, this property may be implemented at a fixed value of 0x30 (Operation status ON).

(2) Detection threshold level

Sets the threshold value that causes EPC = 0xB1 “Invasion occurrence status” to be set to “Found” (8-step). The minimum value is 0x31 and the maximum value is 0x38. No concrete value is specified for each level. If the detection threshold of the actual device is higher or lower than the 8-step range, the property of the actual device shall be assigned to the property value of the 8 steps specified in this property.

(3) Invasion occurrence status

This property indicates whether an invasion occurrence status is found or not. When EPC = 0xB0 “Detection threshold level” is implemented, this property is set to “Invasion occurrence status found” = 0x41 if the threshold set by the detection

threshold level is exceeded. When this property is set to “Invasion occurrence status found” = 0x41, it shall be announced periodically. This property shall be set to “Invasion occurrence status not found” = 0x42 by resetting the main body or by EPC = 0xBF “Invasion occurrence status resetting”.

(4) Invasion occurrence status resetting

Resets EPC = 0xB1 “Invasion occurrence status” by setting 0x00.

3. 1. 3 Requirements for emergency button class

Class group code : 0x00

Class code : 0x03

Instance code : 0x01–0x7F (0x00: All-instance specification code)

Property name	EPC	Contents of property	Data type	Data size	Unit	Access rule	Man-datory	Announcement at status change	Remark
		Value range (decimal notation)							
Operation status	0x80	This property indicates the ON/OFF status.	unsigned char	1 byte	—	Set		○	
		ON=0x30, OFF=0x31				Get			
Emergency occurrence status	0xB1	This property indicates emergency occurrence status.	unsigned char	1 byte	—	Get		○	
		Emergency occurrence status found = 0x41 Emergency occurrence status not found = 0x42							
Emergency occurrence status resetting	0xBF	Resets emergency occurrence status by setting 0x00.	unsigned char	1 byte	—	Set			
		Reset = 0x00							

Note: In the “Announcement at status change” column, ○ denotes mandatory processing when the property is implemented.

(1) Operation status (inherited from the device object super class property)

This property indicates whether the function native to this class is operating or not (ON/OFF). In the node mounting this class, if the function of this class is started concurrently with the start of node operation, this property may be implemented at a fixed value of 0x30 (Operation status ON).

(2) Emergency occurrence status

This property indicates whether an emergency occurrence status caused by pressing the emergency button is found or not. When this property is set to “Emergency occurrence status found” = 0x41, the property shall be announced periodically. This property shall be set to “Emergency occurrence status not found” = 0x42 by resetting the main body or by EPC = 0xBF “Emergency occurrence status resetting”.

(3) Emergency occurrence status resetting

Resets EPC = 0xB1 “Emergency occurrence status” by setting 0x00.

3. 1. 4 Requirements for first-aid sensor class

Class group code : 0x00

Class code : 0x04

Instance code : 0x01–0x7F (0x00: All-instance specification code)

Property name	EPC	Contents of property	Data type	Data size	Unit	Access rule	Mandatory	Announcement at status change	Remark
		Value range (decimal notation)							
Operation status	0x80	This property indicates the ON/OFF status.	unsigned char	1 byte	—	Set		○	
		ON=0x30, OFF=0x31				Get			
Detection threshold level	0xB0	Specifies detection threshold level (8-step).	unsigned char	1 byte	—	Set/Get			
		0x31–0x38							
First-aid occurrence status	0xB1	This property indicates first-aid occurrence status.	unsigned char	1 byte	—	Get	○	○	
		First-aid occurrence status found = 0x41 First-aid occurrence status not found = 0x42							
First-aid occurrence status resetting	0xBF	Resets first-aid occurrence status by setting 0x00.	unsigned char	1 byte	—	Set			
		Reset = 0x00							

Note: In the “Announcement at status change” column, ○ denotes mandatory processing when the property is implemented.

(1) Operation status (inherited from the device object super class property)

This property indicates whether the function native to this class is operating or not (ON/OFF). In the node mounting this class, if the function of this class is started concurrently with the start of node operation, this property may be implemented at a fixed value of 0x30 (Operation status ON).

(2) Detection threshold level

Sets the threshold value that causes EPC = 0xB1 “First-aid occurrence status” to be set to “Found” (8-step). The minimum value is 0x31 and the maximum value is 0x38. No concrete value is specified for each level. If the detection threshold of the actual device is higher or lower than the 8-step range, the property of the actual device shall be assigned to the property value of the 8 steps specified in this property.

(3) First-aid occurrence status

This property indicates whether a first-aid occurrence status is found or not. When EPC = 0xB0 “Detection threshold level” is implemented, this property is set to

“First-aid occurrence status found” if the threshold set by the detection threshold level is exceeded.

When this property is set to “First-aid occurrence status found” = 0x41, the property shall be announced periodically. This property shall be set to “First-aid occurrence status not found” = 0x42 by resetting the main body or by EPC = 0xBF “First-aid occurrence status resetting”.

(4) First-aid occurrence status resetting

Resets EPC = 0xB1 “First-aid occurrence status” by setting 0x00.

3. 1. 5 Requirements for earthquake sensor class

Class group code : 0x00

Class code : 0x05

Instance code : 0x01–0x7F (0x00: All-instance specification code)

Property name	EPC	Contents of property	Data type	Data size	Unit	Access rule	Mandatory	Announcement at status change	Remark
		Value range (decimal notation)							
Operation status	0x80	This property indicates the ON/OFF status.	unsigned char	1 byte	—	Set		○	
		ON=0x30, OFF=0x31				Get			
Detection threshold level	0xB0	Specifies detection threshold level (8-step).	unsigned char	1 byte	—	Set/ Get			
		0x31–0x38							
Earthquake occurrence status	0xB1	This property indicates earthquake occurrence status.	unsigned char	1 byte	—	Get	○	○	
		Earthquake occurrence status found = 0x41 Earthquake occurrence status not found = 0x42							
Earthquake occurrence status resetting	0xBF	Resets earthquake occurrence status by setting 0x00.	unsigned char	1 byte	—	Set			
		Reset = 0x00							

Note: In the “Announcement at status change” column, ○ denotes mandatory processing when the property is implemented.

(1) Operation status (inherited from the device object super class property)

This property indicates whether the function native to this class is operating or not (ON/OFF). In the node mounting this class, if the function of this class is started concurrently with the start of node operation, this property may be implemented at a fixed value of 0x30 (Operation status ON).

(2) Detection threshold level

Sets the threshold value that causes EPC = 0xB1 “Earthquake occurrence status” to be set to “Found” (8-step). The minimum value is 0x31 and the maximum value is 0x38. No concrete value is specified for each level. If the detection threshold of the actual device is higher or lower than the 8-step range, the property of the actual device shall be assigned to the property value of the 8 steps specified in this property.

(3) Earthquake occurrence status

This property indicates whether an earthquake occurrence status is found or not. When EPC = 0xB0 “Detection threshold level” is implemented, this property is set to “Earthquake occurrence status found” if the threshold set by the detection

threshold level is exceeded.

When this property is set to “Earthquake occurrence status found” = 0x41, the property shall be announced periodically. This property shall be set to “Earthquake occurrence status not found” = 0x42 by resetting the main body or by EPC = 0xBF “Earthquake occurrence status resetting”.

(4) Earthquake occurrence status resetting

Resets EPC = 0xB1 “Earthquake occurrence status” by setting 0x00.

3. 1. 6 Requirements for electric leak sensor class

Class group code : 0x00

Class code : 0x06

Instance code : 0x01–0x7F (0x00: All-instance specification code)

Property name	EPC	Contents of property	Data type	Data size	Unit	Access rule	Mandatory	Announcement at status change	Remark
		Value range (decimal notation)							
Operation status	0x80	This property indicates the ON/OFF status.	unsigned char	1 byte	—	Set		○	
		ON=0x30, OFF=0x31				Get	○		
Detection threshold level	0xB0	Specifies detection threshold level (8-step).	unsigned char	1 byte	—	Set/ Get			
		0x31–0x38							
Electric leak occurrence status	0xB1	This property indicates leak occurrence status.	unsigned char	1 byte	—	Get	○	○	
		Electric leak occurrence status found = 0x41 Electric leak occurrence status not found = 0x42							
Electric leak occurrence status resetting	0xBF	Resets electric leak occurrence status by setting 0x00.	unsigned char	1 byte	—	Set			
		Reset = 0x00							

Note: In the “Announcement at status change” column, ○ denotes mandatory processing when the property is implemented.

(1) Operation status (inherited from the device object super class property)

This property indicates whether the function native to this class is operating or not (ON/OFF). In the node mounting this class, if the function of this class is started concurrently with the start of node operation, this property may be implemented at a fixed value of 0x30 (Operation status ON).

(2) Detection threshold level

Sets the threshold value that causes EPC = 0xB1 “Electric leak occurrence status” to be set to “Found” (8-step). The minimum value is 0x31 and the maximum value is 0x38. No concrete value is specified for each level. If the detection threshold of the actual device is higher or lower than the 8-step range, the property of the actual device shall be assigned to the property value of the 8 steps specified in this property.

(3) Electric leak occurrence status

This property indicates whether an electric leak occurrence status is found or not. When EPC = 0xB0 “Detection threshold level” is implemented, this property is set

to “Electric leak occurrence status found” if the threshold set by the detection threshold level is exceeded. When this property is set to “Electric leak occurrence status found” = 0x41, the property shall be announced periodically. This property shall be set to “Electric leak occurrence status not found” = 0x42 by resetting the main body or by EPC = 0xBF “Electric leak occurrence status resetting”.

(4) Electric leak occurrence status resetting

Resets EPC = 0xB1 “Electric leak occurrence status” by setting 0x00.

3. 1. 7 Requirements for human detection sensor class

Class group code : 0x00

Class code : 0x07

Instance code : 0x01–0x7F (0x00: All-instance specification code)

Property name	EPC	Contents of property	Data type	Data size	Unit	Access rule	Mandatory	Announcement at status change	Remark
		Value range (decimal notation)							
Operation status	0x80	This property indicates the ON/OFF status	unsigned char	1 byte	–	Set		○	
		ON=0x30, OFF=0x31				Get	○		
Detection threshold level	0xB0	Specifies detection threshold level (8-step).	unsigned char	1 byte	–	Set/Get			
		0x31–0x38							
Human detection status	0xB1	This property indicates human detection status.	unsigned char	1 byte	–	Get	○	○	
		Human detection status found = 0x41 Human detection status not found = 0x42							

Note: In the “Announcement at status change” column, ○ denotes mandatory processing when the property is implemented.

(1) Operation status (inherited from the device object super class property)

This property indicates whether the function native to this class is operating or not (ON/OFF). In the node mounting this class, if the function of this class is started concurrently with the start of node operation, this property may be implemented at a fixed value of 0x30 (Operation status ON).

(2) Detection threshold level

Sets the threshold value that causes EPC = 0xB1 “Human detection status” to be set to “Found” (8-step). The minimum value is 0x31 and the maximum value is 0x38. No concrete value is specified for each level. If the detection threshold of the actual device is higher or lower than the 8-step range, the property of the actual device shall be assigned to the property value of the 8 steps specified in this property.

(3) Human detection status

This property indicates whether a human detection status is found or not. When EPC = 0xB0 “Detection threshold level” is implemented, this property is set to “Human detection status found” if the threshold set by the detection threshold level is exceeded, and is set to “Human detection status not found” if the detection threshold value is not reached.

3. 1. 8 Requirements for visitor sensor class

Class group code : 0x00

Class code : 0x08

Instance code : 0x01–0x7F (0x00: All-instance specification code)

Property name	EPC	Contents of property	Data type	Data size	Unit	Access rule	Mandatory	Announcement at status change	Remark
		Value range (decimal notation)							
Operation status	0x80	This property indicates the ON/OFF status.	unsigned char	1 byte	–	Set		○	
		ON=0x30, OFF=0x31				Get			
Detection threshold level	0xB0	Specifies detection threshold level (8-step).	unsigned char	1 byte	–	Set/Get			
		0x31–0x38							
Visitor detection status	0xB1	This property indicates visitor detection status.	unsigned char	1 byte	–	Get	○	○	
		Visitor detection status found = 0x41 Visitor detection status not found = 0x42							
Visitor detection holding time	0xBE	This property indicates visitor detection holding time in units of 10 seconds.	unsigned short	2 bytes	10 sec	Set/Get			
		0x0000–0xFFFFD (0 sec.–655,330 sec.)							

Note: In the “Announcement at status change” column, ○ denotes mandatory processing when the property is implemented.

(1) Operation status (inherited from the device object super class property)

This property indicates whether the function native to this class is operating or not (ON/OFF). In the node mounting this class, if the function of this class is started concurrently with the start of node operation, this property may be implemented at a fixed value of 0x30 (Operation status ON).

(2) Detection threshold level

Sets the threshold value that causes EPC = 0xB1 “Visitor detection status” to be set to “Found” (8-step). The minimum value is 0x31 and the maximum value is 0x38. No concrete value is specified for each level. If the detection threshold of the actual device is higher or lower than the 8-step range, the property of the actual device shall be assigned to the property value of the 8 steps specified in this property.

(3) Visitor detection status

This property indicates whether a visitor detection status is found or not. When EPC = 0xB0 “Detection threshold level” is implemented, this property is set to “Visitor

detection status found” if the threshold set by the detection threshold level is exceeded. When this property is set to “Visitor detection status found” = 0x41, the property shall be announced periodically.

(4) Visitor detection holding time

This property indicates the time from start of “Visitor detection status found” to return to “Visitor detection status not found” in units of 10 seconds. The property value range shall be 0x0000 to 0xFFFFD (0 sec. to 655,330 sec.). If the property value of the actual device exceeds the property value range, the overflow code 0xFFFF shall be used.

3. 1. 9 Requirements for call sensor class

Class group code : 0x00

Class code : 0x09

Instance code : 0x01–0x7F (0x00: All-instance specification code)

Property name	EPC	Contents of property	Data type	Data size	Unit	Access rule	Mandatory	Announcement at status change	Remark
		Value range (decimal notation)							
Operation status	0x80	This property indicates the ON/OFF status.	unsigned char	1 byte	–	Set		○	
		ON=0x30, OFF=0x31				Get			
Detection threshold level	0xB0	Specifies detection threshold level (8-step).	unsigned char	1 byte	–	Set/Get			
		0x31–0x38							
Call status	0xB1	This property indicates call status.	unsigned char	1 byte	–	Get	○	○	
		Call status found = 0x41 Call status not found = 0x42							
Call holding time	0xBE	This property indicates the call holding time in units of 10 seconds.	unsigned short	2 bytes	10 sec	Set/Get			
		0x0000–0xFFFF (0 sec.–655,300 sec.)							

Note: In the “Announcement at status change” column, ○ denotes mandatory processing when the property is implemented.

(1) Operation status (inherited from the device object super class property)

This property indicates whether the function native to this class is operating or not (ON/OFF). In the node mounting this class, if the function of this class is started concurrently with the start of node operation, this property may be implemented at a fixed value of 0x30 (Operation status ON).

(2) Detection threshold level

Sets the threshold value that causes EPC = 0xB1 “Call status” to be set to “Found” (8-step). The minimum value is 0x31 and the maximum value is 0x38. No concrete value is specified for each level. If the detection threshold of the actual device is higher or lower than the 8-step range, the property of the actual device shall be assigned to the property value of the 8 steps specified in this property.

(3) Call status

This property indicates whether a call status is found or not. When EPC = 0xB0 “Detection threshold level” is implemented, this property is set to “Call status found” if the threshold set by the detection threshold level is exceeded. When this property is set to “Call status found” = 0x41, the property shall be announced

periodically.

(4) Call holding time

This property indicates the time from start of “Call status found” to return to “Call status not found” in units of 10 seconds. The property value range shall be 0x0000 to 0xFFFFD (0 sec. to 655.330 sec.). If the property value of the actual device exceeds the property value range, the overflow code 0xFFFF shall be used.

3. 1. 10 Requirements for condensation sensor class

Class group code : 0x00

Class code : 0x0A

Instance code : 0x01–0x7F (0x00: All-instance specification code)

Property name	EPC	Contents of property	Data type	Data size	Unit	Access rule	Mandatory	Announcement at status change	Remark
		Value range (decimal notation)							
Operation status	0x80	This property indicates the ON/OFF status.	unsigned char	1 byte	–	Set		○	
		ON=0x30, OFF=0x31				Get			
Detection threshold level	0xB0	Specifies detection threshold level (8-step).	unsigned char	1 byte	–	Set/Get			
		0x31–0x38							
Condensation detection status	0xB1	This property indicates condensation detection status.	unsigned char	1 byte	–	Get	○	○	
		Condensation detection status found = 0x41 Condensation detection status not found = 0x42							

Note: In the “Announcement at status change” column, ○ denotes mandatory processing when the property is implemented.

(1) Operation status (inherited from the device object super class property)

This property indicates whether the function native to this class is operating or not (ON/OFF). In the node mounting this class, if the function of this class is started concurrently with the start of node operation, this property may be implemented at a fixed value of 0x30 (Operation status ON).

(2) Detection threshold level

Sets the threshold value that causes EPC = 0xB1 “Condensation detection status” to be set to “Found” (8-step). The minimum value is 0x31 and the maximum value is 0x38. No concrete value is specified for each level. If the detection threshold of the actual device is higher or lower than the 8-step range, the property of the actual device shall be assigned to the property value of the 8 steps specified in this property.

(3) Condensation detection status

This property indicates whether a condensation detection status is found or not. When EPC = 0xB0 “Detection threshold level” is implemented, this property is set to “Condensation detection status found” if the threshold set by the detection threshold level is exceeded, and is set to “Condensation detection status not found”

if the detection threshold value is not reached.

3. 1. 11 Requirements for air pollution sensor class

Class group code : 0x00

Class code : 0x0B

Instance code : 0x01–0x7F (0x00: All-instance specification code)

Property name	EPC	Contents of property	Data type	Data size	Unit	Access rule	Mandatory	Announcement at status change	Remark
		Value range (decimal notation)							
Operation status	0x80	This property indicates the ON/OFF status.	unsigned char	1 byte	–	Set		○	
		ON=0x30, OFF=0x31				Get			
Detection threshold level	0xB0	Specifies detection threshold level (8-step).	unsigned char	1 byte	–	Set/Get			
		0x31–0x38							
Air pollution detection status	0xB1	This property indicates air pollution detection status.	unsigned char	1 byte	–	Get	○	○	
		Air pollution detection status found = 0x41 Air pollution detection status not found = 0x42							

Note: In the “Announcement at status change” column, ○ denotes mandatory processing when the property is implemented.

(1) Operation status (inherited from the device object super class property)

This property indicates whether the function native to this class is operating or not (ON/OFF). In the node mounting this class, if the function of this class is started concurrently with the start of node operation, this property may be implemented at a fixed value of 0x30 (Operation status ON).

(2) Detection threshold level

Sets the threshold value that causes EPC = 0xB1 “Air pollution detection status” to be set to “Found” (8-step). The minimum value is 0x31 and the maximum value is 0x38. No concrete value is specified for each level. If the detection threshold of the actual device is higher or lower than the 8-step range, the property of the actual device shall be assigned to the property value of the 8 steps specified in this property.

(3) Air pollution detection status

This property indicates whether an air pollution detection status is found or not. When EPC = 0xB0 “Detection threshold level” is implemented, this property is set to “Air pollution detection status found” if the threshold set by the detection threshold level is exceeded, and is set to “Air pollution detection status not found” if

the detection threshold value is not reached.

3. 1. 12 Requirements for oxygen sensor class

Class group code : 0x00

Class code : 0x0C

Instance code : 0x01–0x7F (0x00: All-instance specification code)

Property name	EPC	Contents of property	Data type	Data size	Unit	Access rule	Mandatory	Announcement at status change	Remark
		Value range (decimal notation)							
Operation status	0x80	This property indicates the ON/OFF status.	unsigned short	1byte	—	Set		○	
		ON=0x30, OFF=0x31				Get			
Measured value of oxygen concentration	0xE0	This property indicates measured value of oxygen concentration in units of 0.01%.	unsigned short	2 bytes	0.01%	Get	○		
		0x0000–0x2710 (0.00–100.00%)							

Note: In the “Announcement at status change” column, ○ denotes mandatory processing when the property is implemented.

(1) Operation status (inherited from the device object super class property)

This property indicates whether the function native to this class is operating or not (ON/OFF). In the node mounting this class, if the function of this class is started concurrently with the start of node operation, this property may be implemented at a fixed value of 0x30 (Operation status ON).

(2) Measured value of oxygen concentration

This property indicates the measured value of oxygen concentration in units of 0.01%. The property value range shall be 0x0000 to 0x2710 (0.00 to 100.00%). When the property value of the actual device exceeds this property value range, the overflow code 0xFFFF shall be used. When said value falls below the property value range, the underflow code 0xFFFE shall be used.

3. 1. 13 Requirements for illuminance sensor class

Class group code : 0x00

Class code : 0x0D

Instance code : 0x01–0x7F (0x00: All-instance specification code)

Property name	EPC	Contents of property	Data type	Data size	Unit	Access rule	Mandatory	Announcement at status change	Remark
		Value range (decimal notation)							
Operation status	0x80	This property indicates the ON/OFF status.	unsigned short	1 byte	—	Set		○	
		ON=0x30, OFF=0x31				Get			
Measured illuminance value 1	0xE0	This property indicates measured illuminance value in lux.	unsigned short	2 bytes	lux	Get	○		Note1
		0x0000–0xFFFD (0–65533 lux)							
Measured illuminance value 2	0xE1	This property indicates measured illuminance value in kilo lux.	unsigned short	2 bytes	klux	Get	○		Note1
		0x0000–0xFFFD (0–65533 klux)							

Note: In the “Announcement at status change” column, ○ denotes mandatory processing when the property is implemented.

Note1: Either “Measured illuminance value 1 EPC:0xE0” or “Measured illuminance value 2 EPC:0xE1” is mandatorily implemented.

(1) Operation status (inherited from the device object super class property)

This property indicates whether the function native to this class is operating or not (ON/OFF). In the node mounting this class, if the function of this class is started concurrently with the start of node operation, this property may be implemented at a fixed value of 0x30 (Operation status ON).

(2) Measured illuminance value 1

This property indicates the measured illuminance value in lux. The property value range shall be 0x0000 to FFFD (0 to 65533 lux). When the property value of the actual device exceeds this property value range, the overflow code 0xFFFF shall be used. When said value falls below the property value range, the underflow code 0xFFFE shall be used.

(3) Measured illuminance value 2

This property indicates the measured illuminance value in kilo lux. The property value range shall be 0x0000 to FFFD (0 to 65533 klux). When the property value of the actual device exceeds this property value range, the overflow code 0xFFFF shall

be used. When said value falls below the property value range, the underflow code 0xFFFE shall be used.

3. 1. 14 Requirements for sound sensor class

Class group code : 0x00

Class code : 0x0E

Instance code : 0x01–0x7F (0x00: All-instance specification code)

Property name	EPC	Contents of property	Data type	Data size	Unit	Access rule	Mandatory	Announcement at status change	Remark
		Value range (decimal notation)							
Operation status	0x80	This property indicates the ON/OFF status.	unsigned char	1 byte	–	Set		○	
		ON=0x30, OFF=0x31				Get			
Detection threshold level	0xB0	Specifies detection threshold level (8-step).	unsigned char	1 byte	–	Set/Get			
		0x31–0x38							
Sound detection status	0xB1	This property indicates sound detection status.	unsigned char	1 byte	–	Get	○	○	
		Sound detection status found = 0x41 Sound detection status not found = 0x42							
Sound detection holding time	0xBE	This property indicates sound detection holding time in units of 10 seconds.	unsigned short	2 bytes	10 sec	Set/Get			
		0x0000–0xFFFF (0 sec.–655,330 sec.)							

Note: In the “Announcement at status change” column, ○ denotes mandatory processing when the property is implemented.

(1) Operation status (inherited from the device object super class property)

This property indicates whether the function native to this class is operating or not (ON/OFF). In the node mounting this class, if the function of this class is started concurrently with the start of node operation, this property may be implemented at a fixed value of 0x30 (Operation status ON).

(2) Detection threshold level

Sets the threshold value that causes EPC = 0xB1 “Sound detection status” to be set to “Found” (8-step). The minimum value is 0x31 and the maximum value is 0x38. No concrete value is specified for each level. If the detection threshold of the actual device is higher or lower than the 8-step range, the property of the actual device shall be assigned to the property value of the 8 steps specified in this property.

(3) Sound detection status

This property indicates whether a sound detection status is found or not. When EPC = 0xB0 “Detection threshold level” is implemented, this property is set to “Sound

detection status found” if the threshold set by the detection threshold level is exceeded.

(4) Sound detection holding time

This property indicates the time from start of “Sound detection status found” to return to “Sound detection status not found” in units of 10 seconds. The property value range shall be 0x0000 to 0xFFFFD (0 sec. to 655,330 sec.). If the property value of the actual device exceeds the property value range, the overflow code 0xFFFF shall be used.

3. 1. 15 Requirements for mailing sensor class

Class group code : 0x00

Class code : 0x0F

Instance code : 0x01–0x7F (0x00: All-instance specification code)

Property name	EPC	Contents of property	Data type	Data size	Unit	Access rule	Mandatory	Announcement at status change	Remark
		Value range (decimal notation)							
Operation status	0x80	This property indicates the ON/OFF status.	unsigned char	1 byte	–	Set		○	
		ON=0x30, OFF=0x31				Get			
Detection threshold level	0xB0	Specifies detection threshold level (8-step).	unsigned char	1 byte	–	Set/Get			
		0x31–0x38							
Mailing detection status	0xB1	This property indicates mailing detection status.	unsigned char	1 byte	–	Get	○	○	
		Mailing detection status found = 0x41 Mailing detection status not found = 0x42							

Note: In the “Announcement at status change” column, ○ denotes mandatory processing when the property is implemented.

(1) Operation status (inherited from the device object super class property)

This property indicates whether the function native to this class is operating or not (ON/OFF). In the node mounting this class, if the function of this class is started concurrently with the start of node operation, this property may be implemented at a fixed value of 0x30 (Operation status ON).

(2) Detection threshold level

Sets the threshold value that causes EPC = 0xB1 “Mailing detection status” to be set to “Found” (8-step). The minimum value is 0x31 and the maximum value is 0x38. No concrete value is specified for each level. If the detection threshold of the actual device is higher or lower than the 8-step range, the property of the actual device shall be assigned to the property value of the 8 steps specified in this property.

(3) Mailing detection status

This property indicates whether a mailing detection status is found or not. When EPC = 0xB0 “Detection threshold level” is implemented, this property is set to “Mailing detection status found” if the threshold set by the detection threshold level is exceeded, and is set to “Mailing detection status not found” if the detection threshold value is not reached.

3. 1. 16 Requirements for weight sensor class

Class group code : 0x00

Class code : 0x10

Instance code : 0x01–0x7F (0x00: All-instance specification code)

Property name	EPC	Contents of property	Data type	Data size	Unit	Access rule	Mandatory	Announcement at status change	Remark
		Value range (decimal notation)							
Operation status	0x80	This property indicates the ON/OFF status.	unsigned char	1 byte	–	Set		○	
		ON=0x30, OFF=0x31				Get			
Detection threshold level	0xB0	Specifies detection threshold level (8-step).	unsigned char	1 byte	–	Set/Get			
		0x31–0x38							
Weight detection status	0xB1	This property indicates weight detection status.	unsigned char	1 byte	–	Get	○	○	
		Weight detection status found = 0x41 Weight detection status not found = 0x42							

Note: In the “Announcement at status change” column, ○ denotes mandatory processing when the property is implemented.

(1) Operation status (inherited from the device object super class property)

This property indicates whether the function native to this class is operating or not (ON/OFF). In the node mounting this class, if the function of this class is started concurrently with the start of node operation, this property may be implemented at a fixed value of 0x30 (Operation status ON).

(2) Detection threshold level

Sets the threshold value that causes EPC = 0xB1 “Weight detection status” to be set to “Found” (8-step). The minimum value is 0x31 and the maximum value is 0x38. No concrete value is specified for each level. If the detection threshold of the actual device is higher or lower than the 8-step range, the property of the actual device shall be assigned to the property value of the 8 steps specified in this property.

(3) Weight detection status

This property indicates whether a weight detection status is found or not. When EPC = 0xB0 “Detection threshold level” is implemented, this property is set to “Weight detection status found” if the threshold set by the detection threshold level is exceeded, and is set to “Weight detection status not found” if the detection threshold value is not reached.

3. 1. 17 Requirements for temperature sensor class

Class group code : 0x00

Class code : 0x11

Instance code : 0x01–0x7F (0x00: All-instance specification code)

Property name	EPC	Contents of property	Data type	Data size	Unit	Access rule	Mandatory	Announcement at status change	Remark
		Value range (decimal notation)							
Operation status	0x80	This property indicates the ON/OFF status.	unsigned char	1 byte	—	Set		○	
		ON=0x30, OFF=0x31				Get			
Measured temperature value	0xE0	This property indicates the measured temperature value in units of 0.1°C.	signed short	2 bytes	0.1°C	Get	○		
		0xF554–0x7FFE (-273.2–3276.6°C)							

Note: In the “Announcement at status change” column, ○ denotes mandatory processing when the property is implemented.

(1) Operation status (inherited from the device object super class property)

This property indicates whether the function native to this class is operating or not (ON/OFF). In the node mounting this class, if the function of this class is started concurrently with the start of node operation, this property may be implemented at a fixed value of 0x30 (Operation status ON).

(2) Measured temperature value

This property indicates the measured temperature value in units of 0.1%. The property value range shall be 0xF554 to 0x7FFE (-273.2°C to 3276.6°C). When the property value of the actual device exceeds this property value range, the overflow code 0x8000 shall be used. When said value falls below the property value range, the underflow code 0x7FFE shall be used.

3. 1. 18 Requirements for humidity sensor class

Class group code : 0x00

Class code : 0x12

Instance code : 0x01–0x7F (0x00: All-instance specification code)

Property name	EPC	Contents of property	Data type	Data size	Unit	Access rule	Mandatory	Announcement at status change	Remark
		Value range (decimal notation)							
Operation status	0x80	This property indicates the ON/OFF status.	unsigned char	1 byte	–	Set		○	
		ON=0x30, OFF=0x31				Get	○		
Measured value of relative humidity	0xE0	This property indicates measured value of relative humidity in %.	unsigned char	1 byte	%	Get	○		
		0x00–0x64 (0–100%)							

Note: In the “Announcement at status change” column, ○ denotes mandatory processing when the property is implemented.

(1) Operation status (inherited from the device object super class property)

This property indicates whether the function native to this class is operating or not (ON/OFF). In the node mounting this class, if the function of this class is started concurrently with the start of node operation, this property may be implemented at a fixed value of 0x30 (Operation status ON).

(2) Measured value of relative humidity

This property indicates the measured value of relative humidity in %. The property value range shall be 0x00 to 0x64 (0 to 100%). When the property value of the actual device exceeds this property value range, the overflow code 0xFF shall be used. When said value falls below the property value range, the underflow code 0xFE shall be used.

3. 1. 19 Requirements for rain sensor class

Class group code : 0x00

Class code : 0x13

Instance code : 0x01–0x7F (0x00: All-instance specification code)

Property name	EPC	Contents of property	Data type	Data size	Unit	Access rule	Mandatory	Announcement at status change	Remark
		Value range (decimal notation)							
Operation status	0x80	This property indicates the ON/OFF status.	unsigned char	1 byte	–	Set		○	
		ON=0x30, OFF=0x31				Get			
Detection threshold level	0xB0	Specifies detection threshold level (8-step).	unsigned char	1 byte	–	Set/Get			
		0x31–0x38							
Rain detection status	0xB1	This property indicates rain detection status.	unsigned char	1 byte	–	Get	○	○	
		Rain detection status found = 0x41 Rain detection status not found = 0x42							

Note: In the “Announcement at status change” column, ○ denotes mandatory processing when the property is implemented.

(1) Operation status (inherited from the device object super class property)

This property indicates whether the function native to this class is operating or not (ON/OFF). In the node mounting this class, if the function of this class is started concurrently with the start of node operation, this property may be implemented at a fixed value of 0x30 (Operation status ON).

(2) Detection threshold level

Sets the threshold value that causes EPC = 0xB1 “Rain detection status” to be set to “Found” (8-step). The minimum value is 0x31 and the maximum value is 0x38. No concrete value is specified for each level. If the detection threshold of the actual device is higher or lower than the 8-step range, the property of the actual device shall be assigned to the property value of the 8 steps specified in this property.

(3) Rain detection status

This property indicates whether a rain detection status is found or not. When EPC = 0xB0 “Detection threshold level” is implemented, this property is set to “Rain detection status found” if the threshold set by the detection threshold level is exceeded, and is set to “Rain detection status not found” if the detection threshold value is not reached.

3. 1. 20 Requirements for water level sensor class

Class group code : 0x00

Class code : 0x14

Instance code : 0x01–0x7F (0x00: All-instance specification code)

Property name	EPC	Contents of property	Data type	Data size	Unit	Access rule	Mandatory	Announcement at status change	Remark
		Value range (decimal notation)							
Operation status	0x80	This property indicates the ON/OFF status.	unsigned char	1 byte	–	Set		○	
		ON=0x30, OFF=0x31				Get			
Water level over detection threshold level	0xB0	This property indicates the water level over detection threshold level in cm.	unsigned char	1 byte	cm	Get			
		0x00–0xFD (0–253)							
Water level over detection status	0xB1	This property indicates if the water level exceeds detected water level threshold level.	unsigned char	1 byte	–	Get		○	
		Water level over detection status found = 0x41 Water level over detection status not found = 0x42							
Measured value of water level	0xE0	This property indicates measured value of water level in cm.	unsigned char	1 byte	cm	Get	○		
		0x00–0xFD (0–253)							

Note: In the “Announcement at status change” column, ○ denotes mandatory processing when the property is implemented.

(1) Operation status (inherited from the device object super class property)

This property indicates whether the function native to this class is operating or not (ON/OFF). In the node mounting this class, if the function of this class is started concurrently with the start of node operation, this property may be implemented at a fixed value of 0x30 (Operation status ON).

(2) Water level over detection threshold level

Sets the water level threshold that causes EPC = 0xB1 to be set to “Water level over detection status” in cm.

(3) Water level over detection status

This property indicates whether a water level over detection status is found or not. When EPC = 0xB0 “Detected water level threshold level” is implemented, this property is set to “Water level over detection status found” if the threshold set by the detected water level threshold level is exceeded, and is set to “Water level over detection status not found” if the detection threshold value is not reached.

(4) Measured value of water level

This property indicates the measured value of water level in cm. The property value range shall be 0x00 to 0xFD (0 to 253 cm). When the property value of the actual device exceeds this property value range, the overflow code 0xFF shall be used. When said value falls below the property value range, the underflow code 0xFE shall be used.

3. 1. 21 Requirements for bath water level sensor class

Class group code : 0x00

Class code : 0x15

Instance code : 0x01–0x7F (0x00: All-instance specification code)

Property name	EPC	Contents of property	Data type	Data size	Unit	Access rule	Mandatory	Announcement at status change	Remark
		Value range (decimal notation)							
Operation status	0x80	This property indicates the ON/OFF status.	unsigned char	1 byte	–	Set		○	
		ON=0x30, OFF=0x31				Get			
Bath water level over detection threshold level	0xB0	This property indicates the bath water level over detection threshold level in cm.	unsigned char	1 byte	cm	Get			
		0x00–0xFD (0–253)							
Bath water level over detection status	0xB1	This property indicates if bath water level exceeds detection water level threshold level.	unsigned char	1 byte	–	Get		○	
		Water level over detection status found = 0x41 Water level over detection status not found = 0x42							
Measured value of bath water level	0xE0	This property indicates measured value of bath water level in cm.	unsigned char	1 byte	cm	Get	○		
		0x00–0xFD (0–253)							

Note: In the “Announcement at status change” column, ○ denotes mandatory processing when the property is implemented.

(1) Operation status (inherited from the device object super class property)

This property indicates whether the function native to this class is operating or not (ON/OFF). In the node mounting this class, if the function of this class is started concurrently with the start of node operation, this property may be implemented at a fixed value of 0x30 (Operation status ON).

(2) Bath water level over detection threshold level

Sets the water level threshold that causes EPC = 0xB1 to be set to “Bath water level over detection status” in cm.

(3) Bath water level over detection status

This property indicates whether a predetermined bath water level is exceeded or not. When the “Bath water level over detection threshold level” (EPC = 0xB0) is implemented, the status changes to “Water level over detection status found” when the threshold value set by the “Water level over detection threshold level” is exceeded. When the water level is lower than the threshold level, the status changes

to “Water level over detection status not found”.

(4) Measured value of bath water level

This property indicates the measured value of bath water level in cm. The property value range shall be 0x00 to 0xFD (0 to 253 cm). When the property value of the actual device exceeds this property value range, the overflow code 0xFF shall be used. When said value falls below the property value range, the underflow code 0xFE shall be used.

3. 1. 22 Requirements for bath heating status sensor class

Class group code : 0x00

Class code : 0x16

Instance code : 0x01–0x7F (0x00: All-instance specification code)

Property name	EPC	Contents of property	Data type	Data size	Unit	Access rule	Mandatory	Announcement at status change	Remark
		Value range (decimal notation)							
Operation status	0x80	This property indicates the ON/OFF status.	unsigned char	1 byte	–	Set		○	
		ON=0x30, OFF=0x31				Get			
Detection threshold level	0xB0	Specifies detection threshold level (8-step).	unsigned char	1 byte	–	Set/Get			
		Level 0x31 to 0x38							
Bath heating detection status	0xB1	This property indicates bath heating detection status.	unsigned char	1 byte	–	Get	○	○	
		Bath heating detection status found = 0x41 Bath heating detection status not found = 0x42							

Note: In the “Announcement at status change” column, ○ denotes mandatory processing when the property is implemented.

(1) Operation status (inherited from the device object super class property)

This property indicates whether the function native to this class is operating or not (ON/OFF). In the node mounting this class, if the function of this class is started concurrently with the start of node operation, this property may be implemented at a fixed value of 0x30 (Operation status ON).

(2) Detection threshold level

Sets the threshold value that causes EPC = 0xB1 “Bath heating detection status” to be set to “Found” (8-step). The minimum value is 0x31 and the maximum value is 0x38. No concrete value is specified for each level. If the detection threshold of the actual device is higher or lower than the 8-step range, the property of the actual device shall be assigned to the property value of the 8 steps specified in this property.

(3) Bath heating detection status

This property indicates whether a bath heating detection status is found or not. When EPC = 0xB0 “Detection threshold level” is implemented, this property is set to “Bath heating detection status found” if the threshold set by the detection threshold level is exceeded, and is set to “Bath heating detection status not found” if the

detection threshold value is not reached. When this property is set to “Bath heating detection status found” = 0x41, the property shall be announced periodically.

3. 1. 23 Requirements for water leak sensor class

Class group code : 0x00

Class code : 0x17

Instance code : 0x01–0x7F (0x00: All-instance specification code)

Property name	EPC	Contents of property	Data type	Data size	Unit	Access rule	Mandatory	Announcement at status change	Remark
		Value range (decimal notation)							
Operation status	0x80	This property indicates the ON/OFF status.	unsigned char	1 byte	–	Set		○	
		ON=0x30, OFF=0x31				Get			
Detection threshold level	0xB0	Specifies detection threshold level (8-step).	unsigned char	1 byte	–	Set/Get			
		0x31–0x38							
Water leak detection status	0xB1	This property indicates water leak detection status	unsigned char	1 byte	–	Get	○	○	
		Water leak detection status found = 0x41 Water leak detection status not found = 0x42							

Note: In the “Announcement at status change” column, ○ denotes mandatory processing when the property is implemented.

(1) Operation status (inherited from the device object super class property)

This property indicates whether the function native to this class is operating or not (ON/OFF). In the node mounting this class, if the function of this class is started concurrently with the start of node operation, this property may be implemented at a fixed value of 0x30 (Operation status ON).

(2) Detection threshold level

Sets the threshold value that causes EPC = 0xB1 “Water leak detection status” to be set to “Found” (8-step). The minimum value is 0x31 and the maximum value is 0x38. No concrete value is specified for each level. If the detection threshold of the actual device is higher or lower than the 8-step range, the property of the actual device shall be assigned to the property value of the 8 steps specified in this property.

(3) Water leak detection status

This property indicates whether a water leak detection status is found or not. When EPC = 0xB0 “Detection threshold level” is implemented, this property is set to “Water leak detection status found” if the threshold set by the detection threshold level is exceeded, and is set to “Water leak detection status not found” if the detection threshold value is not reached. When this property is set to “Water leak

detection status found" = 0x41, it shall be announced periodically.

3. 1. 24 Requirements for water overflow sensor class

Class group code : 0x00

Class code : 0x18

Instance code : 0x01–0x7F (0x00: All-instance specification code)

Property name	EPC	Contents of property	Data type	Data size	Unit	Access rule	Mandatory	Announcement at status change	Remark
		Value range (decimal notation)							
Operation status	0x80	This property indicates the ON/OFF status.	unsigned char	1 byte	–	Set		○	
		ON=0x30, OFF=0x31				Get			
Detection threshold level	0xB0	Specifies detection threshold level (8-step).	unsigned char	1 byte	–	Set/Get			
		0x31–0x38							
Water overflow detection status	0xB1	This property indicates water overflow status.	unsigned char	1 byte	–	Get	○	○	
		Water overflow detection status found = 0x41 Water overflow detection status not found = 0x42							

Note: In the “Announcement at status change” column, ○ denotes mandatory processing when the property is implemented.

(1) Operation status (inherited from the device object super class property)

This property indicates whether the function native to this class is operating or not (ON/OFF). In the node mounting this class, if the function of this class is started concurrently with the start of node operation, this property may be implemented at a fixed value of 0x30 (Operation status ON).

(2) Detection threshold level

Sets the threshold value that causes EPC = 0xB1 “Water overflow detection status” to be set to “Found” (8-step). The minimum value is 0x31 and the maximum value is 0x38. No concrete value is specified for each level. If the detection threshold of the actual device is higher or lower than the 8-step range, the property of the actual device shall be assigned to the property value of the 8 steps specified in this property.

(3) Water overflow detection status

This property indicates whether a water overflow detection status is found or not. When EPC = 0xB0 “Detection threshold level” is implemented, this property is set to “Water overflow detection status found” if the threshold set by the detection threshold level is exceeded, and is set to “Water overflow detection status not

found” if the detection threshold value is not reached. When this property is set to “Water overflow detection status found” = 0x41, the property shall be announced periodically.

3. 1. 25 Requirements for fire sensor class

Class group code : 0x00

Class code : 0x19

Instance code : 0x01–0x7F (0x00: All-instance specification code)

Property name	EPC	Contents of property	Data type	Data size	Unit	Access rule	Mandatory	Announcement at status change	Remark
		Value range (decimal notation)							
Operation status	0x80	This property indicates the ON/OFF status.	unsigned char	1 byte	—	Set		○	
		ON=0x30, OFF=0x31				Get			
Detection threshold level	0xB0	Specifies detection threshold level (8-step). Concrete status of each level is not specified.	unsigned char	1 byte	–	Set/Get			
		Level 0x31–0x38							
Fire occurrence detection status	0xB1	This property indicates fire occurrence detection status.	unsigned char	1 byte	–	Get	○	○	
		Fire occurrence detection status found = 0x41 Fire occurrence detection status not found = 0x42							
Fire occurrence detection status resetting	0xBF	Resets fire occurrence detection status by setting 0x00.	unsigned char	1 byte	–	Set			
		Reset = 0x00							

Note: In the “Announcement at status change” column, ○ denotes mandatory processing when the property is implemented.

(1) Operation status (inherited from the device object super class property)

This property indicates whether the function native to this class is operating or not (ON/OFF). In the node mounting this class, if the function of this class is started concurrently with the start of node operation, this property may be implemented at a fixed value of 0x30 (Operation status ON).

(2) Detection threshold level

Sets the threshold value that causes EPC = 0xB1 “Fire occurrence detection status” to be set to “Found” (8-step). The minimum value is 0x31 and the maximum value is 0x38. No concrete value is specified for each level. If the detection threshold of the actual device is higher or lower than the 8-step range, the property of the actual device shall be assigned to the property value of the 8 steps specified in this property.

(3) Fire occurrence detection status

This property indicates whether a fire occurrence status is found or not. When EPC

= 0xB0 “Detection threshold level” is implemented, this property is set to “Fire occurrence detection status found” = 0x41 if the threshold set by the detection threshold level is exceeded. This property shall be set to “Fire occurrence detection status not found” = 0x42 by resetting the main body or by EPC = 0xBF “Fire occurrence detection status resetting”.

(4) Fire occurrence detection status resetting

Resets EPC = 0xB1 “Fire occurrence detection status” by setting 0x00.

3. 1. 26 Requirements for cigarette smoke sensor class

Class group code : 0x00

Class code : 0x1A

Instance code : 0x01–0x7F (0x00: All-instance specification code)

Property name	EPC	Contents of property	Data type	Data size	Unit	Access rule	Mandatory	Announcement at status change	Remark
		Value range (decimal notation)							
Operation status	0x80	This property indicates the ON/OFF status.	unsigned char	1 byte	—	Set		○	
		ON=0x30, OFF=0x31				Get			
Detection threshold level	0xB0	Specifies detection threshold level (8-step). Concrete status of each level is not specified.	unsigned char	1 byte	-	Set/Get			
		Level 0x31–0x38							
Smoke (cigarette) detection status	0xB1	This property indicates smoke (cigarette) detection status.	unsigned char	1 byte	-	Get	○	○	
		Smoke (cigarette) detection status found = 0x41 Smoke (cigarette) detection status not found = 0x42							

Note: In the “Announcement at status change” column, ○ denotes mandatory processing when the property is implemented.

(1) Operation status (inherited from the device object super class property)

This property indicates whether the function native to this class is operating or not (ON/OFF). In the node mounting this class, if the function of this class is started concurrently with the start of node operation, this property may be implemented at a fixed value of 0x30 (Operation status ON).

(2) Detection threshold level

Sets the threshold value that causes EPC = 0xB1 “Smoke (cigarette) detection status” to be set to “Found” (8-step). The minimum value is 0x31 and the maximum value is 0x38. No concrete value is specified for each level. If the detection threshold of the actual device is higher or lower than the 8-step range, the property of the actual device shall be assigned to the property value of the 8 steps specified in this property.

(3) Smoke (cigarette) detection status

This property indicates whether a smoke (cigarette) detection status is found or not. When EPC = 0xB0 “Detection threshold level” is implemented, this property is set to “Smoke (cigarette) detection status found” if the threshold set by the detection threshold level is exceeded, and is set to “Smoke (cigarette) detection status not

found” if the detection threshold value is not reached.

3. 1. 27 Requirements for CO₂ sensor class

Class group code : 0x00

Class code : 0x1B

Instance code : 0x01–0x7F (0x00: All-instance specification code)

Property name	EPC	Contents of property	Data type	Data size	Unit	Access rule	Mandatory	Announcement at status change	Remark
		Value range (decimal notation)							
Operation status	0x80	This property indicates the ON/OFF status.	unsigned char	1 byte	—	Set		○	
		ON=0x30, OFF=0x31				Get	○		
Measured value of CO ₂ concentration	0xE0	This property indicates measured value of CO ₂ concentration in ppm.	unsigned short	2 bytes	ppm	Get	○		
		0x0000–0xFFFFD (0–65533)							

Note: In the “Announcement at status change” column, ○ denotes mandatory processing when the property is implemented.

(1) Operation status (inherited from the device object super class property)

This property indicates whether the function native to this class is operating or not (ON/OFF). In the node mounting this class, if the function of this class is started concurrently with the start of node operation, this property may be implemented at a fixed value of 0x30 (Operation status ON).

(2) Measured value of CO₂ concentration

This property indicates the measured value of CO₂ concentration in ppm. The property value range shall be 0x0000 to 0xFFFFD (0 to 65533 ppm). When the property value of the actual device exceeds this property value range, the overflow code 0xFFFF shall be used. When said value falls below the property value range, the underflow code 0xFFFFE shall be used.

3. 1. 28 Requirements for gas sensor class

Class group code : 0x00

Class code : 0x1C

Instance code : 0x01–0x7F (0x00: All-instance specification code)

Property name	EPC	Contents of property	Data type	Data size	Unit	Access rule	Mandatory	Announcement at status change	Remark
		Value range (decimal notation)							
Operation status	0x80	This property indicates the ON/OFF status.	unsigned char	1 byte	—	Set		○	
		ON=0x30, OFF=0x31				Get			
Detection threshold level	0xB0	Specifies detection threshold level (8-step).	unsigned char	1 byte	-	Set/Get			
		0x31–0x38							
Gas detection status	0xB1	This property indicates gas detection status.	unsigned char	1 byte	-	Get		○	
		Gas detection status found = 0x41 Gas detection status not found = 0x42							
Measured value of gas concentration	0xE0	This property indicates measured value of gas concentration in ppm.	unsigned short	2 bytes	ppm	Get	○		
		0x0000–0xFFFFD (0–65533)							

Note: In the “Announcement at status change” column, ○ denotes mandatory processing when the property is implemented.

(1) Operation status (inherited from the device object super class property)

This property indicates whether the function native to this class is operating or not (ON/OFF). In the node mounting this class, if the function of this class is started concurrently with the start of node operation, this property may be implemented at a fixed value of 0x30 (Operation status ON).

(2) Detection threshold level

Sets the threshold value that causes EPC = 0xB1 “Gas detection status” to be set to “Found” (8-step). The minimum value is 0x31 and the maximum value is 0x38. No concrete value is specified for each level. If the detection threshold of the actual device is higher or lower than the 8-step range, the property of the actual device shall be assigned to the property value of the 8 steps specified in this property.

(3) Gas detection status

This property indicates whether a gas detection status is found or not. When EPC = 0xB0 “Detection threshold level” is implemented, this property is set to “Gas detection status found” if the threshold set by the detection threshold level is

exceeded, and is set to “Gas detection status not found” if the detection threshold value is not reached.

(4) Measured value of gas concentration

This property indicates the measured value of gas concentration units of in ppm. The property value range shall be from 0x0000 to 0xFFFFD (0 to 65533 ppm). When the property value of the actual device exceeds this property value range, the overflow code 0xFFFF shall be used. When said value falls below the property value range, the underflow code 0xFFFFE shall be used.

3. 1. 29 Requirements for VOC sensor class

Class group code : 0x00

Class code : 0x1D

Instance code : 0x01–0x7F (0x00: All-instance specification code)

Property name	EPC	Contents of property	Data type	Data size	Unit	Access rule	Mandatory	Announcement at status change	Remark
		Value range (decimal notation)							
Operation status	0x80	This property indicates the ON/OFF status.	unsigned char	1 byte	—	Set		○	
		ON=0x30, OFF=0x31				Get			
Detection threshold level	0xB0	Specifies detection threshold level (8-step).	unsigned char	1 byte	-	Set/Get			
		0x31–0x38							
VOC detection status	0xB1	This property indicates VOC detection status.	unsigned char	1 byte	-	Get		○	
		VOC detection status found = 0x41 VOC detection status not found = 0x42							
Measured value of VOC concentration	0xE0	This property indicates measured value of VOC concentration in ppm.	unsigned short	2 bytes	ppm	Get	○		
		0x0000–0xFFFD (0–65533)							

Note: In the “Announcement at status change” column, ○ denotes mandatory processing when the property is implemented.

(1) Operation status (inherited from the device object super class property)

This property indicates whether the function native to this class is operating or not (ON/OFF). In the node mounting this class, if the function of this class is started concurrently with the start of node operation, this property may be implemented at a fixed value of 0x30 (Operation status ON).

(2) Detection threshold level

Sets the threshold value that causes EPC = 0xB1 “VOC detection status” to be set to “Found” (8-step). The minimum value is 0x31 and the maximum value is 0x38. No concrete value is specified for each level. If the detection threshold of the actual device is higher or lower than the 8-step range, the property of the actual device shall be assigned to the property value of the 8 steps specified in this property.

(3) VOC detection status

This property indicates whether VOC detection status is found or not. When EPC = 0xB0 “Detection threshold level” is implemented, this property is set to “VOC detection status found” if the threshold set by the detection threshold level is

exceeded, and “VOC detection status not found” if the detection threshold value is not reached.

(4) Measured value of VOC concentration

This property indicates the measured value of VOC concentration units of in ppm. The property value range shall be from 0x0000 to 0xFFFFD (0 to 65533 ppm). When the property value of the actual device exceeds this property value range, the overflow code 0xFFFFF shall be used. When said value falls below the property value range, the underflow code 0xFFFFE shall be used.

3. 1. 30 Requirements for differential pressure sensor class

Class group code : 0x00

Class code : 0x1E

Instance code : 0x01–0x7F (0x00: All-instance specification code)

Property name	EPC	Contents of property	Data type	Data size	Unit	Access rule	Mandatory	Announcement at status change	Remark
		Value range (decimal notation)							
Operation status	0x80	This property indicates the ON/OFF status.	unsigned char	1 byte	—	Set		○	
		ON=0x30, OFF=0x31				Get			
Measured value of differential pressure	0xE0	This property indicates measured value of differential pressure in Pa.	signed short	2 bytes	Pa	Get	○		
		0x8001–0x7FFE (-32767–32766)							

Note: In the “Announcement at status change” column, ○ denotes mandatory processing when the property is implemented.

(1) Operation status (inherited from the device object super class property)

This property indicates whether the function native to this class is operating or not (ON/OFF). In the node mounting this class, if the function of this class is started concurrently with the start of node operation, this property may be implemented at a fixed value of 0x30 (Operation status ON).

(2) Measured value of differential pressure

This property indicates the measured value of differential pressure in units of Pa. The property value range shall be from 0x8001 to 0x7FFD (-32767 to 32766 Pa). When the property value of the actual device exceeds this property value range, the overflow code 0x7FFF shall be used. When said value is below the property value range, the underflow code 0x8000 shall be used.

3. 1. 31 Requirements for air speed sensor class

Class group code : 0x00

Class code : 0x1F

Instance code : 0x01–0x7F (0x00: All-instance specification code)

Property name	EPC	Contents of property	Data type	Data size	Unit	Access rule	Mandatory	Announcement at status change	Remark
		Value range (decimal notation)							
Operation status	0x80	This property indicates the ON/OFF status.	unsigned char	1 byte	—	Set		○	
		ON=0x30, OFF=0x31				Get			
Measured value of air speed	0xE0	This property indicates the measured value of air speed in units of 0.01 m/sec.	unsigned short	2 bytes	0.01 m/sec	Get	○		
		0x0000–0xFFFD (0–65533) (0–655.33 m/sec)							
Air flow direction	0xE1	This property indicates air flow direction in units of degrees.	unsigned short	2 bytes	degree	Get			
		0x0000-0x0168 (0-360°)							

Note: In the “Announcement at status change” column, ○ denotes mandatory processing when the property is implemented.

(1) Operation status (inherited from the device object super class property)

This property indicates whether the function native to this class is operating or not (ON/OFF). In the node mounting this class, if the function of this class is started concurrently with the start of node operation, this property may be implemented at a fixed value of 0x30 (Operation status ON).

(2) Measured value of air speed

This property indicates the measured value of air speed in units of 0.01 m/sec. The property value range shall be from 0x0000 to 0xFFFD (0 to 655.33 m/sec.). When the property value of the actual device exceeds this property value range, the overflow code 0xFFFF shall be used. When said value falls below the property value range, the underflow code 0xFFFE shall be used.

(3) Air flow direction

This property indicates the air flow direction in units of degrees. The measurement range of the direction shall be from 0x0000 to 0x0168 (0° to 360°). The north direction should be 0° (360°) as a rule.

3. 1. 32 Requirements for odor sensor class

Class group code : 0x00

Class code : 0x20

Instance code : 0x01–0x7F (0x00: All-instance specification code)

Property name	EPC	Contents of property	Data type	Data size	Unit	Access rule	Mandatory	Announcement at status change	Remark
		Value range (decimal notation)							
Operation status	0x80	This property indicates the ON/OFF status.	unsigned char	1 byte	—	Set		○	
		ON=0x30, OFF=0x31				Get			
Detection threshold level	0xB0	Specifies detection threshold level (8-step).	unsigned char	1 byte	–	Set/Get			
		Level 0x31–0x38							
Odor detection status	0xB1	This property indicates odor detection status.	unsigned char	1 byte	–	Get			
		Odor detection status found = 0x41 Odor detection status not found = 0x42							
Measured odor value	0xE0	This property indicates measured odor value. The unit is not specified.	unsigned char	1 byte	–	Get	○		
		0x00–0xFD (0–253)							

Note: In the “Announcement at status change” column, ○ denotes mandatory processing when the property is implemented.

(1) Operation status (inherited from the device object super class property)

This property indicates whether the function native to this class is operating or not (ON/OFF). In the node mounting this class, if the function of this class is started concurrently with the start of node operation, this property may be implemented at a fixed value of 0x30 (Operation status ON).

(2) Detection threshold level

Sets the threshold value that causes EPC = 0xB1 “Odor detection status” to be set to “Found” (8-step). The minimum value is 0x31 and the maximum value is 0x38. No concrete value is specified for each level. If the detection threshold of the actual device is higher or lower than the 8-step range, the property of the actual device shall be assigned to the property value of the 8 steps specified in this property.

(3) Odor detection status

This property indicates whether an odor detection status is found or not. When EPC = 0xB0 “Detection threshold level” is implemented, this property is set to “Odor detection status found” if the threshold set by the detection threshold level is

exceeded, and is set to “Odor detection status not found” if the detection threshold value is not reached.

(4) Measured odor value

This property indicates the measured odor value. The unit is not specified. The property value range shall be from 0x00 to 0xFD (0 to 253). When the property value of the actual device exceeds this property value range, the overflow code 0xFF shall be used. When said value falls below the property value range, the underflow code 0xFE shall be used.

3. 1. 33 Requirements for flame sensor class

Class group code : 0x00

Class code : 0x21

Instance code : 0x01–0x7F (0x00: All-instance specification code)

Property name	EPC	Contents of property	Data type	Data size	Unit	Access rule	Mandatory	Announcement at status change	Remark
		Value range (decimal notation)							
Operation status	0x80	This property indicates the ON/OFF status.	unsigned char	1 byte	—	Set		○	
		ON=0x30, OFF=0x31				Get			
Detection threshold level	0xB0	Specifies detection threshold level (8-step).	unsigned char	1 byte	–	Set/Get			
		Detection threshold level 0x31–0x38							
Flame detection status	0xB1	This property indicates flame detection status.	unsigned char	1 byte	–	Get	○	○	
		Flame detection status found = 0x41 Flame detection status not found = 0x42							
Flame detection status resetting	0xBF	Resets flame detection status by setting 0x00.	unsigned char	1 byte	–	Set			
		Reset = 0x00							

Note: In the “Announcement at status change” column, ○ denotes mandatory processing when the property is implemented.

(1) Operation status (inherited from the device object super class property)

This property indicates whether the function native to this class is operating or not (ON/OFF). In the node mounting this class, if the function of this class is started concurrently with the start of node operation, this property may be implemented at a fixed value of 0x30 (Operation status ON).

(2) Detection threshold level

Sets the threshold value that causes EPC = 0xB1 “Flame detection status” to be set to “Found” (8-step). The minimum value is 0x31 and the maximum value is 0x38. No concrete value is specified for each level. If the detection threshold of the actual device is higher or lower than the 8-step range, the property of the actual device shall be assigned to the property value of the 8 steps specified in this property.

(3) Flame detection status

This property indicates whether a flame detection status is found or not. When EPC = 0xB0 “Detection threshold level” is implemented, this property is set to “Flame

detection status found” = 0x41 if the threshold set by the detection threshold level is exceeded. This property shall be set to “Flame detection status not found” = 0x42 by resetting the main body or by EPC = 0xBF “Flame detection status resetting”.

(4) Flame detection status resetting

Resets EPC = 0xB1 “Flame detection status” by setting 0x00.

3. 1. 34 Requirements for electric energy sensor class

Class group code : 0x00

Class code : 0x22

Instance code : 0x01–0x7F (0x00: All-instance specification code)

Property name	EPC	Contents of property	Data type	Data size	Unit	Access rule	Mandatory	Announcement at status change	Remark
		Value range (decimal notation)							
Operation status	0x80	This property indicates the ON/OFF status.	unsigned char	1 byte	—	Set		○	
		ON=0x30, OFF=0x31				Get			
Integral electric energy	0xE0	This property indicates integral electric energy in 0.001kWh.	unsigned long	4 bytes	0.001kWh	Get		○	
		0x00000000–0x3B9AC9FF (0–999,999.999 kWh)							
Medium-capacity sensor instantaneous electric energy	0xE1	This property indicates measured instantaneous electric energy in watts.	signed long	4 byte	W	Get			
		0xC4653601–0x3B9AC9FF (-999,999.999–999,999.999)							
Small-capacity sensor instantaneous electric energy	0xE2	This property indicates instantaneous electric energy in units of 0.1 W.	signed short	2 bytes	0.1 W	Get			
		0x8001–0x7FFE (-3276.7–3276.6)							
Large-capacity sensor instantaneous electric energy	0xE3	This property indicates instantaneous electric energy in units of 0.1 kW.	signed short	2 bytes	0.1 kW	Get			
		0x8001–0x7FFE (-3276.7–3276.6)							
Integral electric energy measurement log	0xE4	This property indicates measurement result log of integral electric energy (0.001kWh) for the past 24 hours in 30-minute sections.	unsigned long × 48	192 bytes	0.001kWh	Get			
		0x00000000–0x3B9AC9F (0–999,999.999) (0–999,999.999 kWh)							
Effective voltage value	0xE5	This property indicates effective voltage value in volts.	unsigned short	2 bytes	V	Get			
		0x0000–0xFFFD (0–65533V)							

Note: In the “Announcement at status change” column, ○ denotes mandatory processing when the property is implemented.

(1) Operation status (inherited from the device object super class property)

This property indicates whether the function native to this class is operating or not (ON/OFF). In the node mounting this class, if the function of this class is started concurrently with the start of node operation, this property may be implemented at a fixed value of 0x30 (Operation status ON).

(2) Integral electric energy

This property indicates the integral electric energy in 0.001kWh. The property value range shall be from 0x00000000 to 0x3B9AC9FF (0 to 999,999.999 kWh). When the integral electric energy overflows, this value shall be incremented from 0x00000000.

(3) Small-capacity sensor instantaneous electric energy

This property indicates the measured value of small-capacity sensor instantaneous electric energy in units of 0.1 W. The property value range shall be from 0x8001 to 0x7FFE (-3276.7 to 3276.6 W). When the property value of the actual device exceeds this property value range, the overflow code 0x7FFF shall be used. When said value falls below the property value range, the underflow code 0x8000 shall be used.

(4) Medium-capacity sensor instantaneous electric energy

This property indicates the measured instantaneous electric energy of the medium-capacity sensor in watts. The value range of the property shall be from 0xC4653601 to 0x3B9AC9FF (-999,999.999 to 999,999.999W). If the property value of the actual device is above or below the value range, 0x7FFFFFFF (overflow code) or 0x80000000 (underflow code) shall be used, respectively.

(5) Large-capacity sensor instantaneous electric energy

This property indicates the measured value of large-capacity sensor instantaneous electric energy in units of 0.1 kW. The property value range shall be from 0x8001 to 0x7FFE (-3276.7 to 3276.6 kW). When the property value of the actual device exceeds this property value range, the overflow code 0x7FFF shall be used. When said value falls below the property value range, the underflow code 0x8000 shall be used.

(6) Integral electric energy measurement log

This property indicates the integral electric energy (0.001kWh) measurement result log for the past 24 hours in 30-minute sections. The measured value in 0.001kWh at each 0 minute and 30 minutes based on the time set in the property name "Current time setting" (EPC = 0x97) shall be indicated in the range from 0x00000000 to 0x3B9AC9FF (0 to 999,999.999 kWh). The property value shall begin with the high-order byte in time series.

(7) Effective voltage value

This property indicates the measured value of effective voltage of the electric energy sensor in volts. This property may be implemented as a fixed value of the rated voltage of measurement.

3. 1. 35 Requirements for current value sensor class

Class group code : 0x00

Class code : 0x23

Instance code : 0x01–0x7F (0x00: All-instance specification code)

Property name	EPC	Contents of property	Data type	Data size	Unit	Access rule	Mandatory	Announcement at status change	Remark
		Value range (decimal notation)							
Operation status	0x80	This property indicates the ON/OFF status.	unsigned char	1 byte	—	Set		○	
		ON=0x30, OFF=0x31				Get			
Measured current value 1	0xE0	This property indicates measured current value in mA.	unsigned long	4 bytes	mA	Get	○		Note1
		0x00000000–0xFFFFFFFF (0–4,294,967,293mA)							
Rated voltage to be measured	0xE1	Rated voltage value to be measured by current sensor	unsigned short	2 bytes	V	Get			
		0x0000–0xFFFF (0–65533V)							
Measured current value 2	0xE2	This property indicates measured current value in mA.	unsigned long	4 bytes	mA	Get	○		Note1
		0x80000001–0x7FFFFFFE (-2,147,483,647–2,147,483,646mA)							

Note: In the “Announcement at status change” column, ○ denotes mandatory processing when the property is implemented.

Note1: Either “Measured current value 1 EPC:0xE0” or “Measured current value 2 EPC:0xE2” is mandatory.

(1) Operation status (inherited from the device object super class property)

This property indicates whether the function native to this class is operating or not (ON/OFF). In the node mounting this class, if the function of this class is started concurrently with the start of node operation, this property may be implemented at a fixed value of 0x30 (Operation status ON).

(2) Measured current value 1

This property indicates the measured current value in mA. When an alternating current is measured, its effective value shall be indicated. The property value range shall be from 0x00000000 to 0xFFFFFFFF (0 to 4,294,967,293 mA). When the property value of the actual device exceeds this property value range, the overflow code 0xFFFFFFFF shall be used. When said value is below the property value range, the underflow code 0xFFFFFFF0 shall be used.

(3) Rated voltage to be measured

This property indicates the rated voltage value to be measured by the current sensor in V. This property may be implemented as a fixed value.

(4) Measured current value 2

This property indicates the measured current value in mA. When an alternating current is measured, its effective value shall be indicated. The property value range shall be from 0x80000001 to 0x7FFFFFFE (-2,147,483,647 to 2,147,483,646mA). When the property value of the actual device exceeds this property value range, the overflow code 0x7FFFFFFF shall be used. When said value is below the property value range, the underflow code 0x80000000 shall be used. The current direction from the source to the equipment shall be positive

3. 1. 36 Requirements for water flow rate sensor class

This class is provided for a water tap or the like and is stipulated for the purpose of measuring the amount of water used.

Class group code : 0x00

Class code : 0x25

Instance code : 0x01–0x7F (0x00: All-instance specification code)

Property name	EPC	Contents of property	Data type	Data size	Unit	Access rule	Mandatory	Announcement at status change	Remark
		Value range (decimal notation)							
Operation status	0x80	This property indicates the ON/OFF status.	unsigned char	1 byte	—	Set		○	
		ON=0x30, OFF=0x31				Get			
Integral flow rate	0xE0	This property indicates measured integral flow in cm ³ .	unsigned long	4 bytes	cm ³	Get			
		0x00000000–0x3B9AC9FF (0–999,999,999)							
Flow rate	0xE2	This property indicates measured instantaneous flow rate in cm ³ /min.	unsigned long	4 bytes	cm ³ /min	Get	○		
		0x0000–0x3B9AC9FF (0–999,999,999)							

Note: In the “Announcement at status change” column, ○ denotes mandatory processing when the property is implemented.

(1) Operation status (inherited from the device object super class property)

This property indicates whether the function native to this class is operating or not (ON/OFF). In the node mounting this class, if the function of this class is started concurrently with the start of node operation, this property may be implemented at a fixed value of 0x30 (operation status ON).

(2) Integral flow rate

This property indicates the integral value of the flow rate in units of cm³. The property value range shall be from 0x00000000 to 0x3B9AC9FF (0 to 999,999,999 cm³). If the measured integral flow of the actual device exceeds this property value range, the overflow code 0xFFFFFFFF shall be set.

(3) Flow rate

This property indicates the flow rate in units of cm³/min. The property value range shall be from 0x00000000 to 0x3B9AC9FF (0 to 999,999,999 cm³/min). If the measured value of flow rate of the actual device exceeds this property value range, the overflow code 0xFFFFFFFF shall be set.

3. 1. 37 Requirements for micromotion sensor class

Class group code : 0x00

Class code : 0x26

Instance code : 0x01–0x7F (0x00: All-instance specification code)

Property name	EPC	Contents of property	Data type	Data size	Unit	Access rule	Mandatory	Announcement at status change	Remark
		Value range (decimal notation)							
Operation status	0x80	This property indicates the ON/OFF status.	unsigned char	1 byte	—	Set		○	
		ON=0x30, OFF=0x31				Get			
Detection threshold level	0xB0	Specifies detection threshold level (8-step).	unsigned char	1 byte	–	Set/Get			
		0x31–0x38							
Micromotion detection status	0xB1	This property indicates whether micromotion is detected or not.	unsigned char	1 byte	–	Get	○	○	
		Micromotion detected = 0x41 Micromotion not detected = 0x42							
Detection counter	0xB2	This property indicates micromotion detection count.	unsigned short	2 bytes	–	Set/Get			
		0x0000–0xFFFFE (0–65534)							
Sampling count	0xBC	This property indicates micromotion detection sampling count.	unsigned short	2 bytes	–	Set/Get			
		0x0000–0xFFFFE (0–65534)							
Sampling cycle	0xBD	This property indicates micromotion detection sampling cycle.	unsigned short	2 bytes	msec	Set/Get			
		0x0000–0xFFFFE (0–65534)							

Note: In the “Announcement at status change” column, ○ denotes mandatory processing when the property is implemented.

(1) Operation status (inherited from the device object super class property)

This property indicates whether the function native to this class is operating or not (ON/OFF). In the node mounting this class, if the function of this class is started concurrently with the start of node operation, this property may be implemented at a fixed value of 0x30 (Operation status ON).

(2) Detection threshold level

Sets 8 levels of threshold values at which the “Micromotion detection status” property (EPC = 0xB1) changes to “Micromotion detected”. The minimum value is 0x31 and the maximum value is 0x38. No concrete value is specified for each level. If the detection threshold of the actual device is higher or lower than the 8-step range, the property of the actual device shall be assigned to the property value of the 8 steps specified in this property.

(3) Micromotion detection status

This property indicates whether a micromotion is detected or not. When the “Detection threshold level” (EPC = 0xB0) is implemented and the threshold value set by the detection threshold level is exceeded, the status shall change to “Micromotion detected”. On the other hand, if the threshold value is not reached, the status shall change to “Micromotion not detected”. When the “Sampling count” (EPC = 0xBC) and “Sampling cycle” (EPC = 0xBD) are implemented, the micromotion detection port and other relevant status shall be checked at time intervals specified by the sampling cycle. When the same micromotion detection state persists during the sampling period specified by the “sampling count” setting (EPC = 0xBD), the status shall change to that state.

(4) Detection counter

This property indicates the number of micromotion detections. Here, the term “micromotion detection” represents the above-mentioned property and does not indicate the number of conclusive detections.

The count shall range from 0x0000 to 0xFFFFE (0 to 65534). If the count limit is exceeded, the overflow code 0xFFFF shall be used. The timing for clearing the counter depends on the application and is not stipulated here.

(5) Sampling count

This property indicates the sampling count for concluding that a micromotion is detected. When this property is implemented, the “Sampling cycle” (EPC = 0xBD) shall be implemented as well. The sampling count shall range from 0x0000 to 0xFFFFE (0 to 65534).

(6) Sampling cycle

This property indicates the sampling cycle for the micromotion detection port, etc. in msec. When this property is implemented, the “Sampling count” (EPC = 0xBC) shall be implemented as well. The sampling cycle value shall vary in msec and range from 0x0000 to 0xFFFFE (0 to 65534).

3. 1. 38 Requirements for passage sensor class

Class group code : 0x00

Class code : 0x27

Instance code : 0x01–0x7F (0x00: All-instance specification code)

Property name	EPC	Contents of property	Data type	Data size	Unit	Access rule	Mandatory	Announcement at status change	Remark
		Value range (decimal notation)							
Operation status	0x80	This property indicates the ON/OFF status.	unsigned char	1 byte	—	Set		○	
		ON=0x30, OFF=0x31				Get			
Detection threshold level	0xB0	Specifies detection threshold level (8-step).	unsigned char	1 byte	–	Set/Get			
		0x31–0x38							
Passage detection hold time	0xBE	This property indicates passage detection hold time in ms.	unsigned char	2 bytes	ms	Set/Get			
		0x0000–0xFFFFD (0–65533 ms)							
Passage detection direction	0xE0	This property indicates direction of passage (one of 8 different directions).	unsigned char	1 byte	–	Get	○	○	
		0x30: No passage. 0x31 to 0x38: Direction of passage. 0x39: Passage detected but not located. Or, a sensor incapable of detecting passage direction was passed.							

Note: In the “Announcement at status change” column, ○ denotes mandatory processing when the property is implemented.

(1) Operation status (inherited from the device object super class property)

This property indicates whether the function native to this class is operating or not (ON/OFF). In the node mounting this class, if the function of this class is started concurrently with the start of node operation, this property may be implemented at a fixed value of 0x30 (Operation status ON).

(2) Detection threshold level

Sets 8 steps of threshold values at which the “Passage detection direction” (EPC = 0xE0) property changes from “No passage” (0x30) to “Passage detected” (0x31 to 0x39). The minimum value is 0x31 and the maximum value is 0x38. No concrete value is specified for each level. If the detection threshold of the actual device is higher or lower than the 8-step range, the property of the actual device shall be assigned to the property value of the 8 steps specified in this property.

(3) Passage detection hold time

This property refers to the time interval between the instant at which the passage detection direction property changes to “Passage detected” (0x31 to 0x39) and the instant at which the property reverts to “No passage”. The property value range shall be 0x0000 to 0xFFFFD (0 to 65533 ms).

(4) Passage detection direction

Uses a value between 0x30 and 0x38 to indicate the two-dimensional direction of passage. The values within the range of 0x31 to 0x38 shall indicate the direction of passage. The values shall indicate 8 different directions clockwise with the value 0x31 representing “IN”.

The value 0x30 indicates the state in which no passage is detected. If a passage is detected but its direction cannot be identified, the value 0x39 shall be taken. The value 0x39 shall also be taken if a passage is detected by a sensor incapable of detecting the direction of passage.

In situations where “Passage detection hold time” (EPC = 0xBE) is implemented, the value of this property shall revert to “No passage” (0x30) if the detection hold time elapses after the property value changes from “No passage” (0x30) to “Passage detected” (0x31 to 0x39).

Even if an actual device (sensor) capable of detecting the direction of passage detects fewer than or more than 8 directions, the passage detection directions of the actual device (sensor) shall be assigned to the 8-direction property values defined here. When two directions are to be detected, their property values shall be 0x31 (IN) and 0x35 (OUT). The directions IN and OUT are not stipulated here.

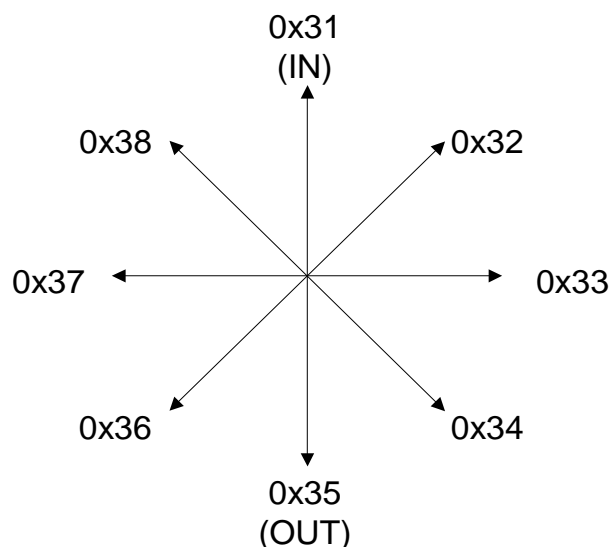

Fig. 3.1 Correspondence between Passage Detection Direction Property Values and Directions

3. 1. 39 Requirements for bed presence sensor class

Class group code : 0x00

Class code : 0x28

Instance code : 0x01–0x7F (0x00: All-instance specification code)

Property name	EPC	Contents of property	Data type	Data size	Unit	Access rule	Mandatory	Announcement at status change	Remark
		Value range (decimal notation)							
Operation status	0x80	This property indicates the ON/OFF status.	unsigned char	1 byte	—	Set		○	
		ON=0x30, OFF=0x31				Get			
Detection threshold level	0xB0	Specifies detection threshold level (8-step).	unsigned char	1 byte	–	Set/Get			
		Detection threshold level 0x31–0x38							
Bed presence detection status	0xB1	This property indicates bed presence detection status.	unsigned char	1 byte	–	Get	○	○	
		Bed presence detected = 0x41, Bed presence not detected = 0x42							

Note: In the “Announcement at status change” column, ○ denotes mandatory processing when the property is implemented.

(1) Operation status (inherited from the device object super class property)

This property indicates whether the function native to this class is operating or not (ON/OFF). In the node mounting this class, if the function of this class is started concurrently with the start of node operation, this property may be implemented at a fixed value of 0x30 (Operation status ON).

(2) Detection threshold level

Sets 8 steps of threshold values at which “Bed presence detection status” (EPC = 0xB1) changes to “Bed presence detected”. The minimum value is 0x31 and the maximum value is 0x38. No concrete value is specified for each level. If the detection threshold of the actual device is higher or lower than the 8-step range, the property of the actual device shall be assigned to the property value of the 8 steps specified in this property.

(3) Bed presence detection status

This property indicates whether a bed presence is detected or not.

In situations where “Detection threshold level” (EPC = 0xB0) is implemented, the status shall change to “Bed presence detected” when the threshold value set by “Detection threshold level” is exceeded. If the threshold value is not reached, on the other hand, the status shall change to “Bed presence not detected”.

3. 1. 40 Requirements for open/close sensor class

Class group code : 0x00

Class code : 0x29

Instance code : 0x01–0x7F (0x00: All-instance specification code)

Property name	EPC	Contents of property	Data type	Data size	Unit	Access rule	Mandatory	Announcement at status change	Remark
		Value range (decimal notation)							
Operation status	0x80	This property indicates the ON/OFF status.	unsigned char	1 byte	—	Set		○	
		ON=0x30, OFF=0x31				Get			
Degree-of-opening detection status 1	0xE0	Specifies open/close detection status and one of 8 different degrees of opening.	unsigned char	1 byte	–	Get	○		Note1
		Close detected: 0x30; Degree-of-opening level: 0x31 to 0x38; Open detected but degree-of-opening unknown: 0x39							
Detection threshold level	0xB0	Specifies detection threshold level (8-step).	unsigned char	1 byte	–	Set/Get			
		Detection threshold level 0x31–0x38							
Degree-of-opening detection status 2	0xB1	Specifies whether degree-of-opening detected or not	unsigned char	1 byte	–	Get	○	○	Note1
		Degree-of-opening detection detected =0x41, not detected =0x42							

Note: In the “Announcement at status change” column, ○ denotes mandatory processing when the property is implemented.

Note1: Either the “Degree-of-opening detection status 1” (EPC = 0xE0) or “Degree-of-opening detection status 2” (EPC = 0xB1) property must be implemented.

(1) Operation status (inherited from the device object super class property)

This property indicates whether the function native to this class is operating or not (ON/OFF). In the node mounting this class, if the function of this class is started concurrently with the start of node operation, this property may be implemented at a fixed value of 0x30 (Operation status ON).

(2) Degree-of-opening detection status

This property indicates whether a door or window is open or closed, and uses 8 different steps to indicate the degree of opening.

The property value 0x30 indicates that a door or window is closed. If the property value is between 0x31 and 0x38, it indicates that the detection target is open. The property value 0x31 indicates the minimum degree of opening, whereas the property value 0x38 indicates the maximum degree of opening. Here, the terms “closed”,

“open”, and “degree of opening” represent various states detected by an open/close sensor mounted on a door or window. Degrees of opening represented by the values 0x31 to 0x38 should be defined by dividing the difference between the closed state (0x30) and fully open state (0x38) into equal portions.

(3) Detection threshold level

Sets 8 steps of threshold values at which “Open /close detection status 2” (EPC = 0xB1) changes to “Open/close detected”. The minimum value is 0x31 and the maximum value is 0x38. No concrete value is specified for each level. If the detection threshold of the actual device is higher or lower than the 8-step range, the property of the actual device shall be assigned to the property value of the 8 steps specified in this property.

(4) Degree-of-opening detection status 2

Specifies detecting of open/close status. In implementing EPC=0xB0 “Detection threshold level”, when the detection level becomes higher than or equal to a threshold value set by the detection threshold level, the degree-of opening detection changes into “degree-of-opening detection detected” =0x41. When the detection level becomes lower than the threshold value set by the detection threshold level, the degree-of opening detection changes into “degree-of-opening detection not detected” =0x42.

3. 1. 41 Requirements for activity amount sensor class

Class group code : 0x00

Class code : 0x2A

Instance code : 0x01–0x7F (0x00: All-instance specification code)

Property name	EPC	Contents of property	Data type	Data size	Unit	Access rule	Mandatory	Announcement at status change	Remark
		Value range (decimal notation)							
Operation status	0x80	This property indicates the ON/OFF status.	unsigned char	1 byte	—	Set		○	
		ON=0x30, OFF=0x31				Get			
Activity amount level 1	0xE0	This property indicates 8 different activity amount levels. The array element number represents a human body ID.	unsigned char × max 128	Max 128 bytes	–	GetM	○		Note1
		0x31–0x38							
Maximum number of human body ID's	0xE1	This property indicates maximum number of human body IDs that can be registered for activity amount level 1.	unsigned short	2 bytes	–	Get			
		0x0001–0x0080 (= 1–128)							
Activity amount level 2	0xE2	This property indicates 8 different activity amount levels.	unsigned char	1 byte	–	Get	○		Note1
		0x31–0x38							
Human body existence information	0xE3	Array element number information retained by activity amount level 1.	unsigned char × 16	16 bytes	–	Get			
		(See (5) below for details.)							

Note: In the “Announcement at status change” column, ○ denotes mandatory processing when the property is implemented.

Note1: Either the “Activity amount level 1” (EPC = 0xE0) or “Activity amount level 2” (EPC = 0xE2) property must be implemented.

(1) Operation status (inherited from the device object super class property)

This property indicates whether the function native to this class is operating or not (ON/OFF). In the node mounting this class, if the function of this class is started concurrently with the start of node operation, this property may be implemented at a fixed value of 0x30 (Operation status ON).

(2) Activity amount level 1

This property indicates 8 different activity amount values. The values 0x31 and 0x38 shall be used as the minimum and maximum values, respectively. However, specific activity amounts for the 8 different levels are not stipulated.

Even if the number of activity amount levels of the actual device is less than or greater than 8, the activity amount levels of the actual device shall be assigned to the

8 different property values defined here.

The array element number represents a human body ID for identifying an individual. If the human body ID associated with an array element number is not found, it is concluded that the associated array element does not exist. The array element number range shall be 0x0000 to 0x007F (0 to 127).

(3) Maximum number of human body ID's

This property indicates the maximum number of human body IDs that can be registered for activity amount level 1.

Eventually, this value is equal to the maximum processable array element number plus 1. Therefore, the property value range shall be 0x0001 to 0x0080 (1 to 128).

(4) Activity amount level 2

Sets 8 different activity amount values. The values 0x31 and 0x38 shall be used as the minimum and maximum values, respectively. However, specific activity amounts for the 8 different levels are not stipulated.

Even if the number of activity amount levels of the actual device is less than or greater than 8, the activity amount levels of the actual device shall be assigned to the 8 property values defined here.

(5) Human body existence information

A bitmap is used to indicate whether or not the array element number information is retained for activity amount level 1. In the following 16-byte table, the value 1 shall be set at bit locations that indicate existing array element numbers.

	Bit 0	Bit 1	Bit 2	Bit 3	Bit 4	Bit 5	Bit 6	Bit 7
1st byte	0000	0001	0002	0003	0004	0005	0006	0007
2nd byte	0008	0009	000A	000B	000C	000D	000E	000F
3rd byte	0010	0011	0012	0013	0014	0015	0016	0017
4th byte	0018	0019	001A	001B	001C	001D	001E	001F
5th byte	0020	0021	0022	0023	0024	0025	0026	0027
6th byte	0028	0029	002A	002B	002C	002D	002E	002F
7th byte	0030	0031	0032	0033	0034	0035	0036	0037
8th byte	0038	0039	003A	003B	003C	003D	003E	003F
9th byte	0040	0041	0042	0043	0044	0045	0046	0047
10 th byte	0048	0049	004A	004B	004C	004D	004E	004F
11 th byte	0050	0051	0052	0053	0054	0055	0056	0057
12 th byte	0058	0059	005A	005B	005C	005D	005E	005F
13 th byte	0060	0061	0062	0063	0064	0065	0066	0067
14 th byte	0068	0069	006A	006B	006C	006D	006E	006F
15 th byte	0070	0071	0072	0073	0074	0075	0076	0077
16 th byte	0078	0079	007A	007B	007C	007D	007E	007F

3. 1. 42 Requirements for human body location sensor

Class group code : 0x00

Class code : 0x2B

Instance code : 0x01–0x7F (0x00: All-instance specification code)

Property name	EPC	Contents of property	Data type	Data size	Unit	Access rule	Mandatory	Announcement at status change	Remark
		Value range (decimal notation)							
Operation status	0x80	This property indicates the ON/OFF status.	unsigned char	1 byte	—	Set		○	
		ON=0x30, OFF=0x31							
Human body detection location 1	0xE0	This property indicates human body detection location. The array element number indicates a human body ID.	unsigned char × 3 × max 128	3 × max 128 bytes	—	GetM	○		Note1
		1st byte: X coordinate; 2nd byte: Y coordinate; 3rd byte: Z coordinate							
Maximum number of human body ID's	0xE1	This property indicates maximum number of human body IDs that can be registered for human body detection location 1.	unsigned short	2 bytes	—	Get			
		0x0001–0x0080 (= 1–128)							
Human body detection location 2	0xE2	This property indicates human body detection location.	unsigned char × 3	3 bytes	—	Get	○		Note1
		1st byte: X coordinate; 2nd byte: Y coordinate; 3rd byte: Z coordinate							
Human body existence information	0xE3	Array element number information retained by human body detection location 1.	unsigned char × 16	16 bytes	—	Get			
		(See (5) below for details.)							

Note: In the “Announcement at status change” column, ○ denotes mandatory processing when the property is implemented.

Note1: Either the “Human body detection location 1” (EPC = 0xE0) or “Human body detection location 2” (EPC = 0xE2) property must be implemented.

(1) Operation status (inherited from the device object super class property)

This property indicates whether the function native to this class is operating or not (ON/OFF). In the node mounting this class, if the function of this class is started concurrently with the start of node operation, this property may be implemented at a fixed value of 0x30 (Operation status ON).

(2) Human body detection location 1

Each array element consists of three data bytes of unsigned char type.

The array element number represents a human body ID that identifies an individual. If the human body ID associated with an array element number is not found, it shall be concluded that no associated array element exists. The array element number

range shall be 0x0000 to 0x007F (0 to 127).

For the 1st, 2nd, and 3rd bytes, the three-dimensional human body detection location (X, Y, and Z coordinates) shall be indicated using 255 different values (0x00 to 0xFE).

For the X, Y, and Z coordinates, the value 0xFF shall mean that the location cannot be identified or is undefined.

If the human body ID associated with an array element number is not found, it shall be concluded that the related array element does not exist.

(3) Maximum array element count

This property indicates the maximum number of human body IDs that can be registered for human body detection location 1.

Eventually, this value is equal to the maximum processable array element number plus 1. Therefore, the property value range shall be 0x0001 to 0x0080 (1 to 128).

(4) Human body detection location 2

For the 1st, 2nd, and 3rd bytes, the three-dimensional human body detection location (X, Y, and Z coordinates) shall be indicated using 255 different values (0x00 to 0xFE).

For the X, Y, and Z coordinates, the value 0xFF shall mean that the location cannot be identified or is undefined.

(5) Human body existence information

A bitmap is used to indicate whether or not the array element number information is retained for human body location 1. In the following 16-byte table, the value 1 shall be set at bit locations that indicate existing array element numbers.

	Bit 0	Bit 1	Bit 2	Bit 3	Bit 4	Bit 5	Bit 6	Bit 7
1st byte	0000	0001	0002	0003	0004	0005	0006	0007
2nd byte	0008	0009	000A	000B	000C	000D	000E	000F
3rd byte	0010	0011	0012	0013	0014	0015	0016	0017
4th byte	0018	0019	001A	001B	001C	001D	001E	001F
5th byte	0020	0021	0022	0023	0024	0025	0026	0027
6th byte	0028	0029	002A	002B	002C	002D	002E	002F
7th byte	0030	0031	0032	0033	0034	0035	0036	0037
8th byte	0038	0039	003A	003B	003C	003D	003E	003F
9th byte	0040	0041	0042	0043	0044	0045	0046	0047
10 th byte	0048	0049	004A	004B	004C	004D	004E	004F
11 th byte	0050	0051	0052	0053	0054	0055	0056	0057
12 th byte	0058	0059	005A	005B	005C	005D	005E	005F
13 th byte	0060	0061	0062	0063	0064	0065	0066	0067
14 th byte	0068	0069	006A	006B	006C	006D	006E	006F

15 th byte	0070	0071	0072	0073	0074	0075	0076	0077
16 th byte	0078	0079	007A	007B	007C	007D	007E	007F

3. 1. 43 Requirements for snow sensor class

Class group code : 0x00

Class code : 0x2C

Instance code : 0x01–0x7F (0x00: All-instance specification code)

Property name	EPC	Contents of property	Data type	Data size	Unit	Access rule	Mandatory	Announcement at status change	Remark
		Value range (decimal notation)							
Operation status	0x80	This property indicates ON/OFF status	unsigned char	1 byte	—	Set		○	
		ON=0x30, OFF=0x31				Get			
Detection threshold level	0xB0	This property indicates threshold levels with 8 steps	unsigned char	1 byte	—	Set/Get			
		0x31-0x38							
Snow detection status	0xB1	This property indicates snow detection	unsigned char	1 byte	—	Get	○	○	
		detected 0x41, not detected 0x42							

Note: In the “Announcement at status change” column, ○ denotes mandatory processing when the property is implemented.

(1) Operation status (Device object super class property inherited)

This property indicates whether the built-in function of this class is operated or not (ON/OFF). When the node equipped with this class begins to work and the function of this class begins to work, it is also possible to be implemented this property with the fixed value 0x30 (operation status ON).

(2) Detection threshold level

Threshold levels turned to “Detected” for EPC=0xB1 “snow detection status” are specified with 8 steps. “0x31” is assigned for a minimum value and “0x38” is assigned for a maximum value. Concrete values assigned for other steps are not specified.

When the number of detection threshold steps is lower than 8 or higher than 8, these 8 steps property values defined by this property must be assigned to actual equipment properties.

(3) Snow detection status

Snow detection status is indicated with “Detected” or “Not detected”. When EPC=0xB0 is implemented and a detection level is higher than or equal to the threshold value specified the detection threshold level, the snow detection status changes into “Detected”. When a sensing level becomes lower than the threshold

value specified the detection threshold level, the snow detection status changes into “Not detected”.

3. 2 Air Conditioner-related Device Class Group

This section specifies detailed codes and properties for each ECHONET object belonging to the air conditioner-related device class group (class group code X1 = 0x01). Table 3-2 shows a list of classes for which detailed specifications are provided. In the requirements of classes, “Mandatory” means that the device mounting each class must mount a combination of its property and service.

Table 3-2 List of Objects of Air Conditioner-related Device Class Group

Group code	Class code	Class name	Whether or not detailed requirements are provided	Remark
0x01	0x00 to 0x2F	For future reserved		
	0x30	Home air conditioner	○	
	0x31	Cold blaster		
	0x32	Electric fan		
	0x33	Ventilation fan	○	
	0x34	Air conditioner ventilation fan	○	
	0x35	Air cleaner	○	
	0x36	Cold blast fan		
	0x37	Circulator		
	0x38	Dehumidifier		
	0x39	Humidifier	○	
	0x3A	Ceiling fan		
	0x3B	Electric Kotatsu		
	0x3C	Electric heating pad		
	0x3D	Electric blanket		
	0x3E	Space heater		
	0x3F	Panel heater		
	0x40	Electric carpet		
	0x41	Floor heater		
	0x42	Electric heater	○	
0x43	Fan heater	○		
0x44	Battery charger			
0x45	Package-type commercial air conditioner (indoor unit)	○		
0x46	Package-type commercial air conditioner (outdoor unit)	○		
0x47	Package-type commercial air conditioner thermal storage unit			
0x48	Commercial fan coil unit			

	0x49	Commercial air conditioning cold source (chiller)		
	0x50	Commercial air conditioning hot source (boiler)		
	0x51	Air-conditioning VAV for commercial applications		
	0x52	Air handling unit (air-conditioning) for commercial applications		
	0x53	Unit-cooler		
	0x54	Condensing unit for commercial applications		
	0x55 to 0xFF	Reserved for future use.		

Note: ○ indicates a detail is explained including a property structure in APPENDIX.

3. 2. 1 Requirements for home air conditioner class

Class group code : 0x01

Class code : 0x30

Instance code : 0x01–0x7F (0x00: All-instance specification code)

Property name	EPC	Contents of property	Data type	Data size	Unit	Access rule	Mandatory	Announcement at status change	Remark
		Value range (decimal notation)							
Operation status	0x80	This property indicates the ON/OFF status.	unsigned char	1 byte	—	Set	○	○	
		ON=0x30, OFF=0x31				Get			
Operation power-saving	0x8F	Used to specify the power-saving operation mode and to acquire the current setting.	unsigned char	1 byte	—	Set/Get	○	○	
		power saving mode = 0x41 normal mode = 0x42							
Operation mode setting	0xB0	Used to specify the operation mode (“automatic,” “cooling,” “heating,” “dehumidification,” “air circulator” or “other”), and to acquire the current setting.	unsigned char	1 byte	—	Set/Get	○	○	
		The following values shall be used: Automatic: 0x41 Cooling: 0x42 Heating: 0x43 Dehumidification: 0x44 Air circulator: 0x45 Other: 0x40							
Automatic temperature control setting	0xB1	Used to specify whether or not to use the automatic temperature control function, and to acquire the current setting.	unsigned char	1 byte	—	Set/Get			
		Automatic = 0x41 Non-automatic = 0x42							
Normal/high-speed/silent operation setting	0xB2	Used to specify the type of operation (“normal,” “high-speed” or “silent”), and to acquire the current setting.	unsigned char	1 byte	—	Set/Get			
		Normal operation: 0x41 High-speed operation: 0x42 Silent operation: 0x43							
Set temperature value	0xB3	Used to set the temperature and to acquire the current setting.	unsigned char	1 byte	°C	Set/Get	○		
		0x00–0x32 (0–50°C)							
Set value of relative humidity in dehumidifying mode	0xB4	Used to set the relative humidity for the “dehumidification” mode and to acquire the current setting.	unsigned char	1 byte	%	Set/Get			
		0x00–0x64 (0–100%)							
Set temperature value in cooling mode	0xB5	Used to set the temperature for the “cooling” mode and to acquire the current setting.	unsigned char	1 byte	°C	Set/Get			
		0x00–0x32 (0–50°C)							
Set temperature value in heating mode	0xB6	Used to set the temperature for the “heating” mode and to acquire the current setting.	unsigned char	1 byte	°C	Set/Get			

		0x00-0x32 (0-50°C)							
Set temperature value in dehumidifying mode	0xB7	Used to set the temperature for the "dehumidification" mode and to acquire the current setting. 0x00-0x32 (0-50°C)	unsigned char	1 byte	°C	Set/Get			
Rated power consumption	0xB8	Rated power consumption in each operation mode of cooling/heating/dehumidifying/blast 0x0000-0xFFFFD (0-65533W) Cooling: heating: dehumidifying: blast	unsigned short × 4	8 bytes	W	Get			
Measured value of current consumption	0xB9	Measured value of current consumption 0x0000-0xFFFFD (0-6553.3A)	unsigned short	2 bytes	0.1A	Get			
Measured value of room relative humidity	0xBA	Measured value of room relative humidity 0x00-0x64 (0-100°C)	unsigned char	1 byte	%	Get			
Measured value of room temperature	0xBB	Measured value of room temperature 0x80-0x7D (-127-125°C)	signed char	1 byte	°C	Get	○		
Set temperature value of user remote control	0xBC	Set temperature value of user remote control 0x00-0x32 (0-50°C)	unsigned char	1 byte	°C	Get			
Measured cooled air temperature	0xBD	This property indicates the measured cooled air temperature at the outlet. 0x81-0x7D (-127-125°C)	signed char	1 byte	°C	Get			
Measured outdoor air temperature	0xBE	This property indicates the measured outdoor air temperature. 0x81-0x7D (-127-125°C)	signed char	1 byte	°C	Get			
Relative temperature setting	0xBF	Used to set the relative temperature relative to the target temperature for an air conditioner operation mode, and to acquire the current setting. 0x81-0x7D (-12.7°C-12.5°C)	unsigned char	1 byte	0.1 °C	Set/Get			
Air flow rate setting	0xA0	Used to specify the air flow rate or use the function to automatically control the air flow rate, and to acquire the current setting. The air flow rate shall be selected from among the 8 predefined levels. Automatic air flow rate control function used = 0x41 Air flow rate = 0x31-0x38	unsigned char	1 byte	-	Set/Get	○	○	
Automatic control of air flow direction setting	0xA1	Used to specify whether or not to use the automatic air flow direction control function, to specify the plane(s) (vertical and/or horizontal) in which the automatic air flow direction control function is to be used, and to acquire the current setting. Automatic = 0x41, non-automatic = 0x42, automatic (vertical) = 0x43, automatic (horizontal) = 0x44	unsigned char	1 byte	-	Set/Get			
Automatic swing of air flow setting	0xA3	Used to specify whether or not to use the automatic air flow swing function, to specify the plane(s) (vertical and/or horizontal) in which the automatic air flow swing function is to be used, and to acquire the current setting.	unsigned char	1 byte	-	Set/Get			

		Automatic air flow swing function not used = 0x31, used (vertical) = 0x41, used (horizontal) = 0x42, used (vertical and horizontal) = 0x43							
Air flow direction (vertical) setting	0xA4	Used to specify the air flow direction in the vertical plane by selecting a pattern from among the 5 predefined patterns, and to acquire the current setting. Uppermost = 0x41, lowermost = 0x42, central = 0x43, midpoint between uppermost and central = 0x44, midpoint between lowermost and central = 0x45	unsigned char	1 byte	–	Set/Get			
Air flow direction (horizontal) setting	0xA5	Used to specify the air flow direction(s) in the horizontal plane by selecting a pattern from among the 31 predefined patterns, and to acquire the current setting. Rightward = 0x41, leftward = 0x42, central = 0x43, rightward and leftward = 0x44 (for a full list of the predefined patterns, see the table in the subsection defining the detailed requirements for this property.	unsigned char	1 byte	–	Set/Get			
Special state	0xAA	This property indicates if the air conditioner is in a “special” state (i.e. the “defrosting,” “preheating,” or “heat removal” state). “Normal operation” state = 0x40, “Defrosting” state = 0x41, “Preheating” state = 0x42, “Heat removal” state = 0x43	unsigned char	1 byte	–	Get			
Non-priority state	0xAB	Used to indicate when the air conditioner is in a “non-priority” state. “Normal operation” state = 0x40, “Non-priority” state = 0x41	unsigned char	1 byte	–	Get			
Ventilation function setting	0xC0	Used to specify whether or not to use the ventilation function, to specify the ventilation direction, and to acquire the current setting. Ventilation function ON (outlet direction) = 0x41, ventilation function OFF = 0x42, ventilation function ON (intake direction) = 0x43	unsigned char	1 byte	–	Set/Get			
Humidifier function setting	0xC1	Used to specify whether or not to use the humidifier function, and to acquire the current setting. Humidifier function ON = 0x41, Humidifier function OFF = 0x42	unsigned char	1 byte	–	Set/Get			
Ventilation air flow rate setting	0xC2	Used to specify the ventilation air flow rate by selecting a level from among the predefined levels, and to acquire the current setting. Automatic control of ventilation air flow rate = 0x41, ventilation air flow rate = 0x31–0x38	unsigned char	1 byte	–	Set/Get			
Degree of humidification setting	0xC4	Used to specify the degree of humidification to achieve by selecting a level from among the predefined levels, and to acquire the current setting.	unsigned char	1 byte	–	Set /Get			

		Automatic control of the degree of humidification = 0x41 Degree of humidification = 0x31-0x38							
Mounted air cleaning method	0xC6	A bitmap indicates mounted method of exercising air cleaning function. Bit 0: Information about electrical dust collection method mounting 0 - Not mounted 1 - Mounted Bit 1: Information about cluster ion method mounting 0 - Not mounted 1 - Mounted	unsigned char	1 byte	-	Get			
Air purifier function setting	0xC7	An 8-byte array used to specify, for each type of air purifier function, whether or not to use the air purifier function and the degree of air purification to achieve with the air purifier function, and to acquire the current settings. Element 0: Indicates whether or not to use the electrical dust collection-based air purifier function. Element 1: Indicates whether or not to use the cluster ion-based air purifier function. Elements 2 to 7: Reserved for future use.	unsigned char × 8	1 byte × 8	-	SetM /GetM Set /Get			
Mounted air refresh method	0xC8	A bitmap indicates mounted method for exercising refresh function. Bit 0: Information about minus ion method mounting 0 - Not mounted 1 - Mounted Bit 1: Information about cluster ion method mounting 0 - Not mounted 1 - Mounted	unsigned char	1 byte	-	Get			
Air refresher function setting	0xC9	An 8-byte array used to specify, for each type of air refresher function, whether or not to use the air refresher function and the degree of air refreshing to achieve with the air refresher function, and to acquire the current settings. Element 0: Indicates whether or not to use the minus ion-based air refresher function. Element 1: Indicates whether or not to use the cluster ion-based air refresher function. Elements 2-7: Reserved for future use.	unsigned char × 8	1 byte × 8	-	SetM /GetM Set /Get			
Mounted self-cleaning method	0xCA	A bitmap indicates mounted method for exercising self-cleaning function. Bit 0: Information about ozone cleaning method mounting 0 - Not mounted 1 - Mounted Bit 1: Information about drying method mounting 0 - Not mounted 1 - Mounted	unsigned char	1 byte	-	Get			

Self-cleaning function setting	0xCB	An 8-byte array used to specify, for each type of self-cleaning function, whether or not to use the self-cleaning function and the degree of self-cleaning to achieve with the self-cleaning function, and to acquire the current settings.	unsigned char × 8	1 byte × 8	–	SetM /GetM			
		Element 0: Indicates whether or not to use the ozone-based self-cleaning function. Element 1: Indicates whether or not to use the drying-based self-cleaning function. Elements 2–7: Reserved for future use.							
Special function setting	0xCC	Used to specify the “special function” to use, and to acquire the current setting.	unsigned char	1 byte	–	Set /Get			
		No setting: 0x40, clothes dryer function: 0x41, condensation suppressor function: 0x42, mite and mold control function: 0x43, active defrosting function: 0x44 0x45–: Reserved for future use.							
Operation status of components	0xCD	This property indicates the operation status of components of the air conditioner in a bitmap format.	unsigned char	1 byte	–	Get			
		Bit 0: Operation status of the compressor: 0: Not operating 1: In operation Bit 1: Operation status of the thermostat: 0: Thermostat OFF 1: Thermostat ON Bits 2–7: Reserved for future use.							
Thermostat setting override function	0xCE	Used to specify whether or not to allow the air conditioner to operate ignoring its thermostat setting.	unsigned char	1 byte	–	Set/Get			
		Normal setting = 0x40, thermostat setting override function ON = 0x41, thermostat setting override function OFF = 0x42							
Air purification mode setting	0xCF	Used to set the air purification mode setting ON/OFF and to acquire the current setting.	unsigned char	1 byte	–	Set/Get			
		Air purification ON=0x41, OFF=0x42							
ON timer-based reservation setting	0x90	Used to specify whether or not to use the ON timer (time-based reservation function, relative time-based reservation function or both), and to acquire the current setting.	unsigned char	1 byte	–	Set/Get			
		Both the time- and relative time-based reservation functions are ON = 0x41, both reservation functions are OFF = 0x42, time-based reservation function is ON = 0x43, relative time-based reservation function is ON = 0x44							
ON timer setting (time)	0x91	Used to specify the time for the time-based reservation function in the HH:MM format and to acquire the current setting.	unsigned char × 2	2 bytes	–	Set/Get			
		0–0x17: 0–0x3B (= 0–23): (= 0–59)							

ON timer setting (relative time)	0x92	Used to specify the relative time for the relative time-based reservation function in the HH:MM format and to acquire the current setting.	unsigned char × 2	2 bytes	–	Set/Get			
		0-0xFF: 0-0x3B (= 0-255): (= 0-59)							
OFF timer-based reservation setting	0x94	Used to specify whether or not to use the OFF timer (time-based reservation function, relative time-based reservation function or both), and to acquire the current setting.	unsigned char	1 byte	–	Set/Get			
		Both the time- and relative time-based reservation functions are ON = 0x41, both reservation functions are OFF = 0x42, time-based reservation function is ON = 0x43, relative time-based reservation function is ON = 0x44							
OFF timer setting (time)	0x95	Used to specify the time for the time-based reservation function in the HH:MM format and to acquire the current setting.	unsigned char × 2	2 bytes	–	Set/Get			
		0-0x17: 0-0x3B (= 0-23): (= 0-59)							
OFF timer setting (relative time)	0x96	Used to specify the relative time for the relative time-based reservation function in the HH:MM format and to acquire the current setting.	unsigned char × 2	2 bytes	–	Set/Get			
		0-0xFF: 0-0x3B (= 0-255): (= 0-59)							

Note: In the “Announcement at status change” column, ○ denotes mandatory processing when the property is implemented.

- (1) Operation status (inherited from the device object super class property.)
Used to specify whether to turn on or off the household air conditioner, and to acquire the current operation status. 0x30 and 0x31 shall be used for the ON and OFF states, respectively.
- (2) Power-saving operation setting (inherited from the device object super class property)
Used to specify the operation mode of the household air conditioner (“normal mode” (not saving power) or “power-saving mode”) and to acquire the current operation status. 0x41 and 0x42 shall be used for normal mode (not saving power) and power-saving mode, respectively. For “Life watching service,” “Announcement at status change” is mandatory.
- (3) Operation mode setting
Used to specify the operation mode of the household air conditioner (“automatic,” “cooling,” “heating,” “dehumidification,” “air circulator” or “other”) and to acquire the current setting. “Other” represents an operation mode other than the 5 modes. 0x41, 0x42, 0x43, 0x44, 0x45 and 0x40 shall be used for “automatic,” “cooling,” “heating,” “dehumidification,” “air circulator” and “other,” respectively. It is only

required to implement the property values that correspond to the modes supported by the actual piece of equipment in which this class is implemented. For example, if the piece of equipment in which this class is implemented does not have an air circulator function, it is not necessary to implement the value for the air circulator mode (0x45).

This property shall be effective even when the value of the “operation status” property (0x80) is OFF (0x31).

(4) Automatic temperature control setting

Used (i) to specify whether or not to use an automatic temperature control function of a household air conditioner that allows the air conditioner to operate based on an automatic temperature setting calculation algorithm, etc. implemented in the main body of the air conditioner and without using as the target any “temperature setting” property (EPC = 0xB3, 0xB5, 0xB6 or 0xB7) and (ii) to acquire the current setting. 0x41 and 0x42 shall be used for the ON and OFF states, respectively.

This property shall be effective even when the value of the “operation status” property (0x80) is OFF (0x31).

(5) Normal/high-speed/silent operation setting

Used to specify the type of operation (“normal,” “high-speed” or “silent”) and to acquire the current setting. 0x41, 0x42 and 0x43 shall be used for “normal,” “high-speed” and “silent,” respectively. This property can be used in combination with the “operation mode setting” property (EPC = 0xB0) to achieve “high-speed (rapid) cooling,” “high-speed (rapid) heating,” “high-speed (strong) dehumidification,” etc. The 3 types of operation (“normal,” “high-speed” and “silent”) are mutually exclusive.

(6) Set temperature value

Used to set the temperature (°C) for the current operation mode of the air conditioner that is specified by the “operation mode setting” property, and to acquire the current setting. The value of this property shall be used as the target temperature when the air conditioner does not have an automatic temperature control function or when it has an automatic temperature control function that is disabled (by the “‘automatic temperature control’ setting” property). The value to be used when the specified target temperature is indeterminable as a result of enabling the automatic temperature control function shall be 0xFD (temperature indeterminable).

This property shall be effective even when the value of the “operation status”

property (0x80) is OFF (0x31).

(7) Set value of relative humidity in dehumidifying mode

Used to set the relative humidity (in %) for the “dehumidification” mode (as specified by the “operation mode setting” property (EPC = 0xB0)), and to acquire the current setting. Implementation of this property allows values to be specified and acquired even when a mode other than the “dehumidification” mode is specified by the “operation mode setting” property (EPC = 0xB0).

This property shall be effective even when the value of the “operation status” property (0x80) is OFF (0x31).

(8) Set temperature value in cooling mode

Used to set the temperature (°C) for the “cooling” mode (as specified by the “operation mode setting” property (EPC = 0xB0)), and to acquire the current setting. Implementation of this property allows values to be specified and referenced even when a mode other than the “cooling” mode is specified by the “operation mode setting” property (EPC = 0xB0).

The value of this property shall be used as the target temperature when the air conditioner does not have an automatic temperature control function or when it has an automatic temperature control function that is disabled (by the “automatic temperature control’ setting” property).

The content of this property must match the content of the “temperature setting” property (EPC = 0xB3).

This property shall be effective even when the value of the “operation status” property (0x80) is OFF (0x31).

(9) Set temperature value in heating mode

Used to set the temperature (°C) for the “heating” mode (as specified by the “operation mode setting” property (EPC = 0xB0)), and to acquire the current setting. Implementation of this property allows values to be specified and referenced even when a mode other than the “heating” mode is specified by the “operation mode setting” property (EPC = 0xB0).

The value of this property shall be used as the target temperature when the air conditioner does not have an automatic temperature control function or when it has an automatic temperature control function that is disabled (by the “automatic temperature control’ setting” property).

The content of this property must match the content of the “temperature setting” property (EPC = 0xB3).

This property shall be effective even when the value of the “operation status” property (0x80) is OFF (0x31).

(10) Set temperature value in dehumidifying mode

Used to set the temperature (°C) for the “dehumidification” mode (as specified by the “operation mode setting” property (EPC = 0xB0)), and to acquire the current setting. Implementation of this property allows values to be specified and referenced even when a mode other than the “dehumidification” mode is specified by the “operation mode setting” property (EPC = 0xB0).

The value of this property shall be used as the target temperature when the air conditioner does not have an automatic temperature control function or when it has an automatic temperature control function that is disabled (by the “automatic temperature control’ setting” property).

The content of this property must match the content of the “temperature setting” property (EPC = 0xB3).

This property shall be effective even when the value of the “operation status” property (0x80) is OFF (0x31).

(11) Rated power consumption

This property indicates, in watts, the rated power consumption values (brochure values) for the “cooling,” “heating,” “dehumidification” and “air circulator” modes. The range of rated power consumption value for each of the 4 modes shall be 0x0000 to 0xFFFFD (0 to 65533W) and the bytes shall be used in such a manner that the four values are indicated in the order stated in the previous sentence. When the actual piece of equipment does not support one or more of the four modes, the underflow code 0xFFFFE shall be used for the unsupported mode(s).

This property shall be effective even when the value of the “operation status” property (0x80) is OFF (0x31).

(12) Measured value of current consumption

This property indicates the present measured electric current consumption of the air conditioner in 0.1A increments. When the measured electric current is alternating current, the effective value shall be indicated. The property value range shall be 0x0000 to 0xFFFFD (0 to 6553.3A). When the property value of the actual piece of

equipment is higher than the upper limit of the property value range, the overflow code 0xFFFF shall be used. When the property value is lower than the lower limit of the property value range, the underflow code 0xFFFE shall be used.

(13) Measured value of room relative humidity

This property indicates the measured indoor relative humidity in %. The property value range shall be 0x00 to 0x64 (0 to 100%). When the property value of the actual piece of equipment is higher than the upper limit of the property value range, the overflow code 0xFF shall be used. When the property value is lower than the lower limit of the property value range, the underflow code 0xFE shall be used. When the measurement value cannot be returned, 0xFD shall be used. This property shall be effective even when the value of the “operation status” property (0x80) is OFF (0x31).

(14) Measured value of room temperature

This property indicates the measured room temperature (°C). The property value range shall be 0x81 to 0x7D (-127 to 125°C). When the property value of the actual piece of equipment is higher than the upper limit of the property value range, the overflow code 0x7F shall be used. When the property value is lower than the lower limit of the property value range, the underflow code 0x80 shall be used. When the measurement value cannot be returned, 0x7E shall be used. This property shall be effective even when the value of the “operation status” property (0x80) is OFF (0x31).

(15) Set temperature value of user remote control

This property indicates the last temperature (°C) set by the user using a remote controller unit for the household air conditioner. This property is mainly used for reference purposes after changing the temperature setting for the household air conditioner by means of a controller, etc. This property shall be effective even when the value of the “operation status” property (0x80) is OFF (0x31).

(16) Measured cooled air temperature

This property indicates the measured cooled air temperature (°C) at the outlet. The property value range shall be 0x81 to 0x7D (-127 to 125°C). When the property value of the actual piece of equipment is higher than the upper limit of the property

value range, the overflow code 0x7F shall be used. When the property value is lower than the lower limit of the property value range, the underflow code 0x80 shall be used. When the measurement value cannot be returned, 0x7E shall be used. This property shall be effective even when the value of the “operation status” property (0x80) is OFF (0x31).

(17) Measured outdoor air temperature

This property indicates the measured air temperature (°C) (outdoor atmospheric temperature) where the outdoor unit is installed. The property value range shall be 0x81 to 0x7D (-127 to 125°C). When the property value of the actual piece of equipment is higher than the upper limit of the property value range, the overflow code 0x7F shall be used. When the property value is lower than the lower limit of the property value range, the underflow code 0x80 shall be used. When the measurement value cannot be returned, 0x7E shall be used.

This property shall be effective even when the value of the “operation status” property (0x80) is OFF (0x31).

(18) Relative temperature setting

Used to specify, in 0.1°C increments, the relative temperature relative to the target temperature (i.e. the temperature differential above or below the target temperature the user wishes to achieve) for an operation mode of the household air conditioner and to acquire the current setting. It is also possible to use this property to specify a relative temperature for an operation mode that does not use an absolute value of temperature as the target such as the “automatic” mode. The property value range shall be 0x81 to 0x7D (-12.7 to 12.5°C). 0xF6 shall be used for a differential of 1.0°C below the target temperature and 0x0A shall be used for a differential of 1.0°C above the target temperature.

When the property value of the actual piece of equipment is higher than the upper limit of the property value range, the overflow code 0x7F shall be used. When the property value is lower than the lower limit of the property value range, the underflow code 0x80 shall be used. When the setting cannot be returned, 0x7E shall be used.

This property shall be effective even when the value of the “operation status” property (0x80) is OFF (0x31).

(19) Air flow rate setting

Used to specify the air flow rate or to specify using the function to automatically control the air flow rate, and to acquire the current setting. The air flow rate shall be selected from among the 8 levels predefined in the 0x31 to 0x38 range. When the automatic air flow rate control function is used, the property value shall be 0x41. The air flow rate values for the 8 levels may be defined freely, as long as 0x31 and 0x38 are used for the minimum and maximum air flow rates, respectively. This property shall be effective even when the value of the “operation status” property (0x80) is OFF (0x31). For “Life watching service,” “Announcement at status change” is mandatory.

(20) Automatic control of air flow direction setting

Used to specify whether or not to use the automatic air flow direction control function, to specify the plane(s) (vertical and/or horizontal) in which the automatic air flow direction control function is to be used, and to acquire the current setting. Automatic (vertical and horizontal) = 0x41, non-automatic = 0x42, automatic (vertical) = 0x43, automatic (horizontal) = 0x44

It is only required to implement the property values that correspond to the functions provided by the actual piece of equipment in which this class is implemented. This property shall be effective even when the value of the “operation status” property (0x80) is OFF (0x31).

(21) Automatic swing of air flow setting

Used to specify whether or not to use the automatic air flow swing function, to specify the plane(s) (vertical and/or horizontal) in which the automatic air flow swing function is to be used, and to acquire the current setting.

Automatic air flow swing function not used = 0x31, used (vertical) = 0x41, used (horizontal) = 0x42, used (vertical and horizontal) = 0x43

It is only required to implement the property values that correspond to the functions provided by the actual piece of equipment in which this class is implemented.

(22) Air flow direction (vertical) setting

Used to specify the air flow direction in the vertical plane by selecting a pattern from among the 5 predefined patterns and to acquire the current setting.

Uppermost = 0x41, lowermost = 0x42, central = 0x43, midpoint between uppermost and central = 0x44, midpoint between lowermost and central = 0x45

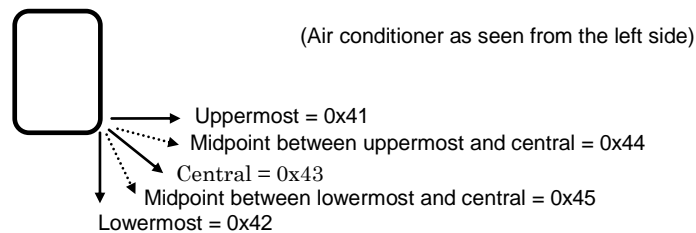

It is only required to implement the property values that correspond to the directions supported by the actual piece of equipment in which this class is implemented. Applicability of this property to the automatic air flow swing function shall be equipment-dependent.

(23) Air flow direction (horizontal) setting

Used to specify the air flow direction(s) in the horizontal plane by selecting a pattern (i.e. “left,” “midpoint between left and central,” “central,” “midpoint between right and central” or “right” or a combination of two or more of the 5 directions; see the table below (○ = active)), and to acquire the current setting. It is only required to implement the property values that correspond to the directions supported by the actual piece of equipment in which this class is implemented. Applicability of this property to the automatic air flow swing function shall be equipment-dependent.

Code	Left	Left center	Center	Right center	Right	Remarks	Code	Left	Left center	Center	Right center	Right	Remarks
0x41	×	×	×	○	○	Earlier version "Right"							
42	○	○	×	×	×	Earlier version "Left"							
43	×	○	○	○	×	Earlier version "Center"							
44	○	○	×	○	○	Earlier version "Left-right"	0x60	○	×	×	×	×	
51	×	×	×	×	○		61	○	×	×	×	○	
52	×	×	×	○	×		62	○	×	×	○	×	
0x53: Not used (because of 0x41 = earlier version "right")							63	○	×	×	○	○	
54	×	×	○	×	×		64	○	×	○	×	×	
55	×	×	○	×	○		65	○	×	○	×	○	
56	×	×	○	○	×		66	○	×	○	○	×	
57	×	×	○	○	○		67	○	×	○	○	○	
58	×	○	×	×	×		0x68: Not used (because of 0x42 = earlier version "left")						
59	×	○	×	×	○		69	○	○	×	×	○	
5A	×	○	×	○	×		6A	○	○	×	○	×	
5B	×	○	×	○	○		0x6B: Not used (because of 0x44 = earlier version "left-right")						

5C	×	○	○	×	×		6C	○	○	○	×	×	
5D	×	○	○	×	○		6D	○	○	○	×	○	
0x5E: Not used (because of 0x43 = earlier version "center")							6E	○	○	○	○	×	
5F	×	○	○	○	○		6F	○	○	○	○	○	

The five directions are as indicated at right.

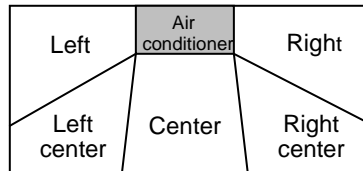

(Top view)

(24) Special state

This property indicates when the household air conditioner is in a “special” state, namely, the “defrosting,” “preheating,” or “heat removal” state.

0x41, 0x42 and 0x43 shall be used for the “defrosting,” “preheating,” and “heat removal” states, respectively. When the air conditioner is in a state other than the “defrosting,” “preheating” and “heat removal” states, 0x40 shall be used.

The “preheating” state shall mean a state in which the compressor is being preheated with the indoor unit fan rotating at a low speed or not rotating, after the heating function is activated or after completion of a defrosting cycle, to allow the air conditioner to supply warm air.

The “heat removal” state shall mean a state in which a fan (the indoor unit fan in most cases) is rotating and the refrigerating cycle is operating to release the residual heat from the air conditioner after the air conditioner is turned off (especially after being used in the heating mode).

This property shall be effective even when the value of the “operation status” property (0x80) is OFF (0x31).

(25) Non-priority state

This property indicates when the household air conditioner is in a “non-priority” state. An example of a household air conditioner (indoor unit) in a “non-priority” state would be one that shares an outdoor unit with another air conditioner (indoor unit) and cannot operate in some of its operating modes because of limitations imposed by the operating mode of the other air conditioner (indoor unit).

0x40 and 0x41 shall be used for the “normal operation” and “non-priority” states, respectively.

This property shall be effective even when the value of the “operation status” property (0x80) is OFF (0x31).

(26) Ventilation function setting

Used to specify whether or not to use the ventilation function of the household air conditioner, to specify the ventilation direction, and to acquire the current setting. Ventilation function ON (outlet direction) = 0x41, ventilation function OFF = 0x42, ventilation function ON (intake direction) = 0x43, ventilation function ON (intake and outlet directions) = 0x44

This property shall be effective even when the value of the “operation status” property (0x80) is OFF (0x31).

(27) Humidifier function setting

Used to specify whether or not to use the humidifier function of the household air conditioner, and to acquire the current setting. Humidifier function ON = 0x41, humidifier function OFF = 0x42

This property shall be effective even when the value of the “operation status” property (0x80) is OFF (0x31).

(28) Ventilation air flow rate setting

Used to specify the ventilation air flow rate by selecting a level from among the 8 predefined levels (0x31 to 0x38) or to specify using the function to automatically control the ventilation air flow rate (0x41 = automatic ventilation air flow rate control used), and to acquire the current setting.

The ventilation air flow rate values for the 8 levels may be defined freely, as long as 0x31 and 0x38 are used for the minimum and maximum ventilation air flow rates, respectively.

This property shall be effective even when the value of the “operation status” property (0x80) is OFF (0x31).

(29) Degree of humidification setting

Used to specify the amount of moisture to add for humidification by selecting a level from among the 8 predefined levels (0x31 to 0x38) or to specify using the function to automatically control the amount of moisture to add (0x41 = automatic control used), and to acquire the current setting. The moisture values for the 8 levels may be defined freely, as long as 0x31 and 0x38 are used for the minimum and maximum amounts, respectively. This property shall be effective even when the value of the “operation status” property (0x80) is OFF (0x31).

(30) Mounted air cleaning method

This property indicates, in bitmap format, the air purifier function(s) supported by the air conditioner. A value of “0” for Bit 0 or Bit 1 shall mean that the air conditioner is not equipped with an electrical dust collection-based or cluster ion-based air purifier function, respectively, and a value of “1” for Bit 0 or Bit 1 shall mean that the air conditioner is equipped with an electrical dust collection-based or cluster ion-based air purifier function, respectively.

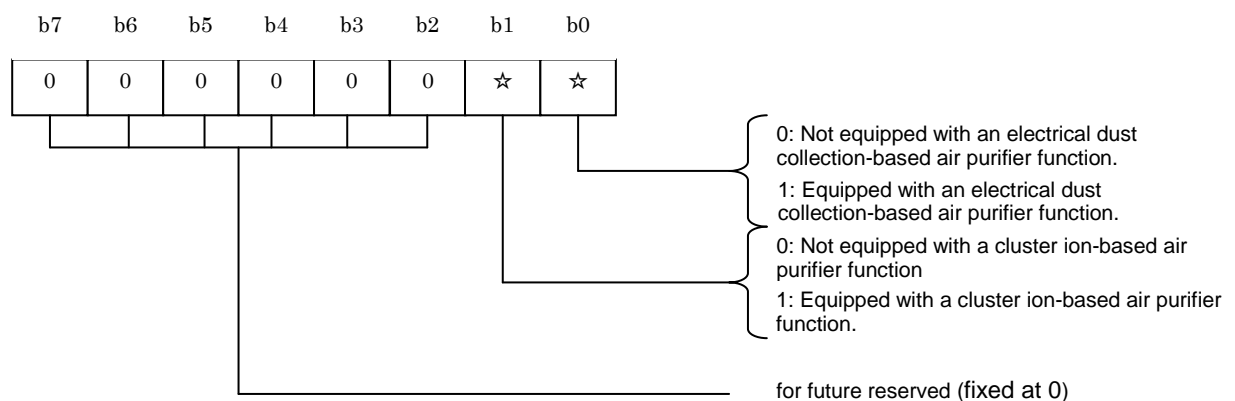

This property shall be effective even when the value of the “operation status” property (0x80) is OFF (0x31).

(31) Air purifier function setting

An 8-element array is used to specify, for each type of air purifier function, whether or not to use the air purifier function, whether or not to use the function to automatically control the degree of air purification, the degree of air purification to achieve with the air purifier function when the function to automatically control the degree of air purification is not used, and to acquire the current settings.

Each element of the array is used for a different type of air purifier function:

- Element 0: Electrical dust collection type
- Element 1: Cluster ion type
- Elements 2 to 7: Reserved for future use.

The size of each element is 1 byte. Bits 0 through 2 are used to specify the degree of air purification to achieve with the air purifier function by selecting a level from the 8 predefined levels (000b to 111b). The degree of air purification for the 8 levels may be defined freely, as long as 000b and 111b are used for the lowest and highest levels, respectively. Bit 3 specifies whether or not to use the air purifier function (“OFF” when the value of Bit 3 is “0” and “ON” when the value of Bit 3 is “1”). Bit

4 specifies whether or not to use the function to automatically control the degree of air purification for the air purifier function (“non-automatic” when the value of Bit 4 is “0” and “automatic” when the value of Bit 4 is “1”). When the value of Bit 4 is “1” (automatic), the degree of air purification specified by Bits 0 through 2 becomes ineffective. The figure below illustrates the composition of an element.

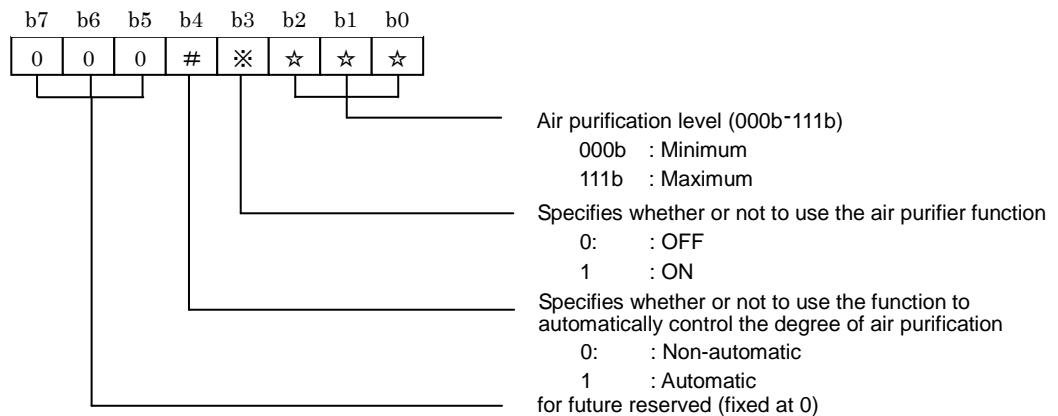

This property shall be effective even when the value of the “operation status” property (0x80) is OFF (0x31).

(32) Mounted air refresh method

This property indicates, in bitmap format, the air refresher function(s) supported by the air conditioner. A value of “0” for Bit 0 or Bit 1 shall mean that the air conditioner is not equipped with a minus ion-based or cluster ion-based air refresher function, respectively, and a value of “1” for Bit 0 or Bit 1 shall mean that the air conditioner is equipped with a minus ion-based or cluster ion-based air refresher function, respectively.

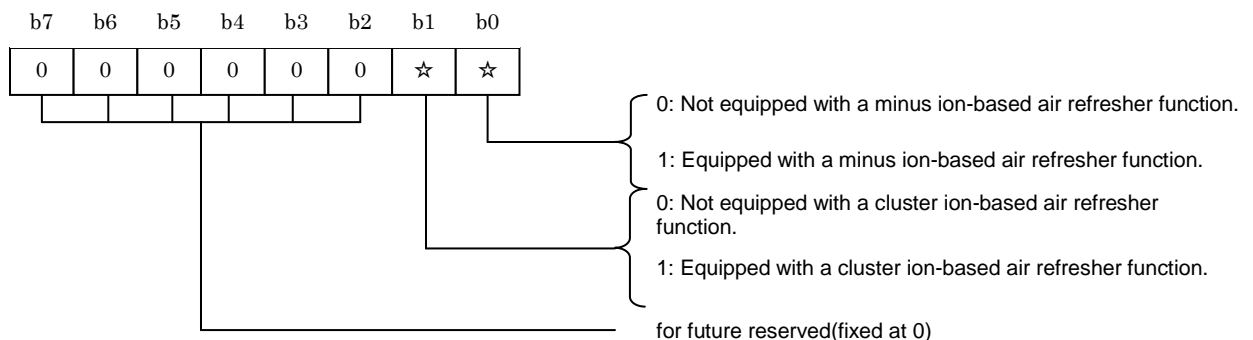

This property shall be effective even when the value of the “operation status” property (0x80) is OFF (0x31).

(33) Air refresher function setting

An 8-element array is used to specify, for each type of air refresher function, whether or not to use the air refresher function, whether or not to use the function to automatically control the degree of air refreshing, the degree of air refreshing to achieve with the air refresher function when the function to automatically control the degree of air refreshing is not used, and to acquire the current settings.

Each element of the array is used for a different type of air refresher function:

Element 0: Negative ion type

Element 1: Cluster ion type

Elements 2 to 7: Reserved for future use.

The size of each element is 1 byte. Bits 0 through 2 are used to specify the degree of air refreshing to achieve with the air refresher function by selecting a level from the 8 predefined levels (000b to 111b). The degree of air refreshing for the 8 levels may be defined freely, as long as 000b and 111b are used for the lowest and highest levels, respectively. Bit 3 specifies whether or not to use the air refresher function (“OFF” when the value of Bit 3 is “0” and “ON” when the value of Bit 3 is “1”). Bit 4 specifies whether or not to use the function to automatically control the degree of air refreshing for the air refresher function (“non-automatic” when the value of Bit 4 is “0” and “automatic” when the value of Bit 4 is “1”). When the value of Bit 4 is “1” (automatic), the degree of air refreshing specified by Bits 0 through 2 becomes ineffective. The figure below illustrates the composition of an element.

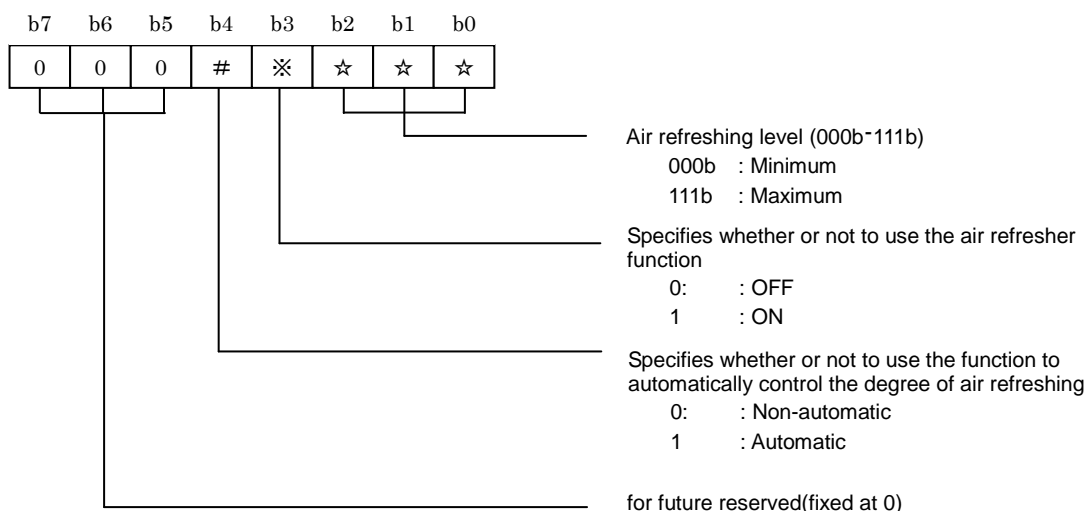

This property shall be effective even when the value of the “operation status” property (0x80) is OFF (0x31).

(34) Mounted self-cleaning method

This property indicates, in bitmap format, the self-cleaning function(s) supported by the air conditioner. A value of “0” for Bit 0 or Bit 1 shall mean that the air conditioner is not equipped with an ozone-based or drying-based self-cleaning function, respectively, and a value of “1” for Bit 0 or Bit 1 shall mean that the air conditioner is equipped with an ozone-based or drying-based self-cleaning function, respectively.

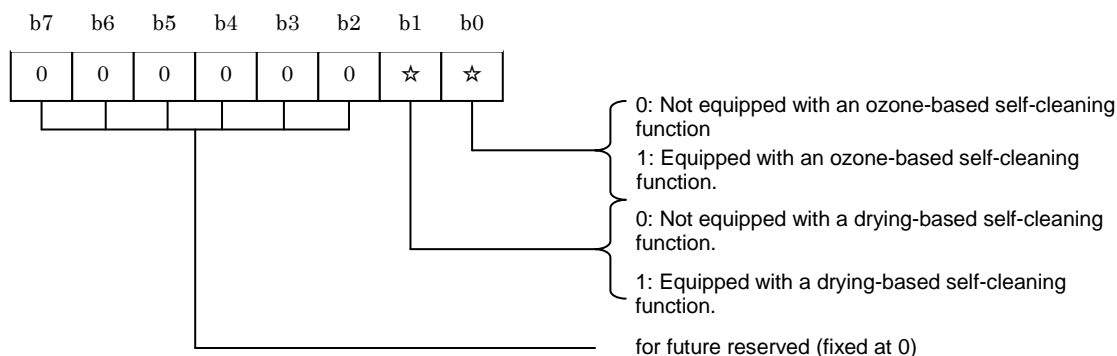

This property shall be effective even when the value of the “operation status” property (0x80) is OFF (0x31).

(35) Self-cleaning function setting

An 8-element array is used to specify, for each type of self-cleaning function, whether or not to use the self-cleaning function, whether or not to use the function to automatically control the degree of self-cleaning, the degree of self-cleaning to achieve with the self-cleaning function when the function to automatically control the degree of self-cleaning is not used, and to acquire the current settings.

Each element of the array is used for a different type of self-cleaning function:

- Element 0: Ozone-type
- Element 1: Drying-type
- Elements 2 to 7: Reserved for future use.

The size of each element is 1 byte. Bits 0 through 2 are used to specify the degree of self-cleaning to achieve with the self-cleaning function by selecting a level from the

8 predefined levels (000b to 111b). The degree of self-cleaning for the 8 levels may be defined freely, as long as 000b and 111b are used for the lowest and highest levels, respectively. Bit 3 specifies whether or not to use the self-cleaning function (“OFF” when the value of Bit 3 is “0” and “ON” when the value of Bit 3 is “1”). Bit 4 specifies whether or not to use the function to automatically control the degree of self-cleaning for the self-cleaning function (“non-automatic” when the value of Bit 4 is “0” and “automatic” when the value of Bit 4 is “1”). When the value of Bit 4 is “1” (automatic), the degree of self-cleaning specified by Bits 0 through 2 becomes ineffective. The figure below illustrates the composition of an element.

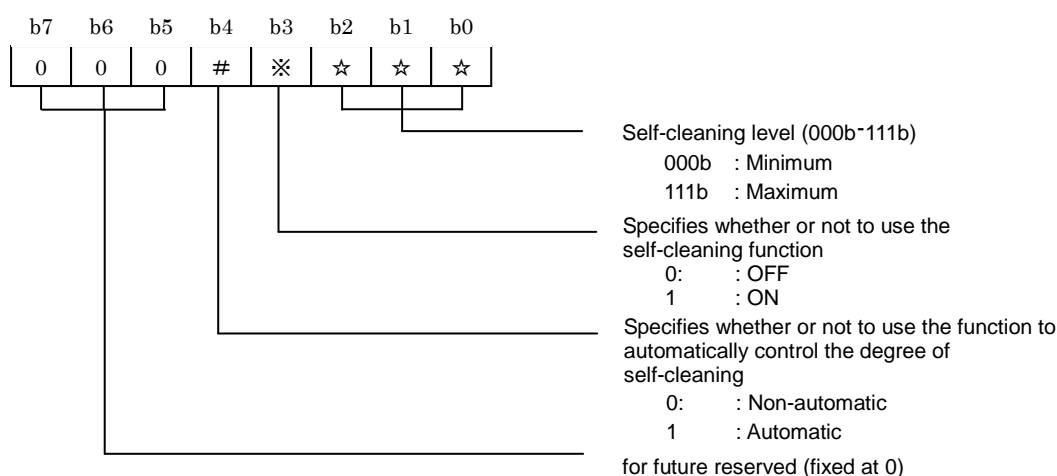

This property shall be effective even when the value of the “operation status” property (0x80) is OFF (0x31).

(36) Special function setting

Used to specify the “special function” to use in the mode specified by the “operation mode setting” property (0xB0), and to acquire the current setting. 0x41, 0x42, 0x43 and 0x44 shall be used for the clothes dryer function, condensation suppressor function, mite and mold control function and active defrosting function, respectively. When none of the 4 special functions are specified, 0x40 shall be used. 0x45 and succeeding values shall be reserved for future use.

In cases where any one of the special functions is designed in such a way that setting the value for that function in the “special function’ setting” property necessitates an “operation mode setting” property (0xB0) value change to ensure consistency between the content of the “operation mode setting” property and the content of the “special function’ setting” property, a means shall be provided to automatically make any required change to the content of the “operation mode

setting” property. For instance, if the clothes dryer function is designed to only operate in the “heating” mode, the “operation mode setting” property value must be changed to the value for the “heating” mode whenever the clothes dryer function is specified and the “operation mode setting” property value is that for a function other than the “heating” mode. However, the relationship between the two properties shall be implementation-dependent and is not specified in this ECHONET Specification. It is only required to implement the property values that correspond to the functions provided by the actual piece of equipment in which this class is implemented. This property shall be effective even when the value of the “operation status” property (0x80) is OFF (0x31).

(37) Operation status of components

This property indicates the operation status of the air conditioner components in bitmap format.

Bit 0: Operation status of the compressor:

0: Not operating

1: In operation

Bit 1: Operation status of the thermostat:

0: Thermostat OFF

1: Thermostat ON

Bits 2 to 7: Reserved for future use.

The “thermostat OFF” state shall mean a state in which “the air conditioner is in operation but the target temperature has been achieved (i.e. the difference between the room temperature and the room temperature setting is less than the specified value) and no heat exchange is being made.” The “thermostat ON” state shall mean a state in which “the difference between the room temperature and the room temperature setting is equal to or more than the specified value and heat exchange is being made to achieve the target temperature.”

This property shall be effective even when the value of the “operation status” property (0x80) is OFF (0x31).

(38) Thermostat setting override function

Used to specify whether or not the household air conditioner shall operate ignoring its thermostat setting.

Normal setting = 0x40, thermostat setting override function ON = 0x41, thermostat

setting override function OFF = 0x42

The “normal setting” mode is a mode in which the air conditioner is dynamically and automatically switched from the “thermostat ON” state to the “thermostat OFF” state or from the “thermostat OFF” state to the “thermostat ON” state as appropriate depending on the room and outdoor temperatures (The air conditioner remains in operation even after it is switched to the “thermostat OFF” state). The “thermostat setting override function ON” mode is a mode in which the air conditioner continues performing heat exchange ignoring the temperature setting and the “thermostat setting override function OFF” mode is a mode in which the air conditioner performs no heat exchange regardless of the temperature setting. This property shall be effective even when the value of the “operation status” property (0x80) is OFF (0x31).

(39) Air purification mode setting

Used to turn on (0x41)/ off (0x42) the air purification function mode of the household air conditioner, and to acquire the current setting.

This property shall be effective even when the value of the “Operation status” property (0x80) is OFF (0x31).

(40) ON timer-based reservation setting

Used to specify whether or not to use the ON timer (time-based reservation function, relative time-based reservation function or both), and to acquire the current setting.

This property is used in combination with the “ON timer setting (time)” or “ON timer setting (relative time)” property.

Both the time- and relative time-based reservation functions are ON = 0x41, both reservation functions are OFF = 0x42, time-based reservation function is ON = 0x43, relative time-based reservation function is ON = 0x44

This property shall be effective even when the value of the “operation status” property (0x80) is OFF (0x31).

(41) ON timer setting (time)

When the ““ON timer-based reservation’ setting” property value is a value for using the time-based reservation function, this property is used to specify the time when the air conditioner will be turned on in the “hour (0x00 to 0x17 (0 to 23)) : minute (0x00 to 0x3B (0 to 59))” format, and to acquire the current setting. The higher- and lower-order bytes shall be used for the “hour” and “minute” values, respectively.

This property shall be effective even when the value of the “operation status”

property (0x80) is OFF (0x31).

(42) ON timer setting (relative time)

When the ““ON timer-based reservation’ setting” property value is a value for using the relative time-based reservation function, this property is used to specify the time when the air conditioner will be turned on, in terms of a relative time relative to the current time, and to acquire the current setting. The “hour (0x00 to 0xFF (0 to 255)) : minute (0x00 to 0x3B (0 to 59))” format shall be used, with the higher- and lower-order bytes used for the “hour” and “minute” values, respectively.

This property shall be effective even when the value of the “operation status” property (0x80) is OFF (0x31).

(43) OFF timer-based reservation setting

Used to specify whether or not to use the OFF timer (time-based reservation function, relative time-based reservation function or both), and to acquire the current setting. This property is used in combination with the “OFF timer setting (time)” or “OFF timer setting (relative time)” property.

Both the time- and relative time-based reservation functions are ON = 0x41, both reservation functions are OFF = 0x42, time-based reservation function is ON = 0x43, relative time-based reservation function is ON = 0x44

This property shall be effective even when the value of the “operation status” property (0x80) is OFF (0x31).

(44) OFF timer setting (time)

When the ““OFF timer-based reservation’ setting” property value is a value for using the time-based reservation function, this property is used to specify the time when the air conditioner will be turned off in the “hour (0x00 to 0x17 (0 to 23)) : minute (0x00 to 0x3B (0 to 59))” format, and to acquire the current setting. The higher- and lower-order bytes shall be used for the “hour” and “minute” values, respectively.

This property shall be effective even when the value of the “operation status” property (0x80) is OFF (0x31).

(45) OFF timer setting (relative time)

When the ““OFF timer-based reservation’ setting” property value is a value for using the relative time-based reservation function, this property is used to specify

the time when the air conditioner will be turned off, in terms of a relative time relative to the current time, and to acquire the current setting. The “hour (0x00 to 0xFF (0 to 255)) : minute (0x00 to 0x3B (0 to 59))” format shall be used, with the higher- and lower-order bytes used for the “hour” and “minute” values, respectively. This property shall be effective even when the value of the “operation status” property (0x80) is OFF (0x31).

3. 2. 2 Requirements for ventilation fan class

Class group code : 0x01

Class code : 0x33

Instance code : 0x01–0x7F (0x00: All-instance specification code)

Property name	EPC	Contents of property	Data type	Data size	Unit	Access rule	Mandatory	Announcement at status change	Remark
		Value range (decimal notation)							
Operation status	0x80	This property indicates the ON/OFF status.	unsigned char	1 byte	—	Set	○	○	
		ON=0x30, OFF=0x31				Get	○		
Ventilation auto setting	0xBF	Auto/Non-auto	unsigned char	1 byte	-	Set/Get			
		Auto = 0x41, Non-auto = 0x42							
Set value of ventilation air flow rate	0xA0	Sets ventilation air flow rate level and ventilation air flow rate auto status. This property specifies ventilation air flow rate level (8-step).	unsigned char	1 byte	-	Set/Get			
		Ventilation air flow rate auto status = 0x41 Ventilation air flow rate level = 0x31–0x38							

Note: In the “Announcement at status change” column, ○ denotes mandatory processing when the property is implemented.

(1) Operation status (inherited from the device object super class property)

This property indicates the operation/stop status of the ventilation fan. The property value of 0x30/0x31 shall be associated with both operation and stop.

(2) Ventilation auto setting

Sets either Auto or Non-auto for the auto ventilating operation.

Auto = 0x41, Non-auto = 0x42

(3) Set value of ventilation air flow rate

This property indicates the ventilation air flow rate level and the ventilation air flow rate auto status. The property value of the ventilation air flow rate auto status shall be 0x41. The air flow rate level shall be set (8-step) and take a property value of 0x31 to 0x38. The values for the 8 levels may be defined freely, as long as 0x31 and 0x38 are used for the minimum and maximum air flow rates, respectively.

3. 2. 3 Requirements for air conditioner ventilation fan class

Class group code : 0x01

Class code : 0x34

Instance code : 0x01–0x7F (0x00: All-instance specification code)

Property name	EPC	Contents of property	Data type	Data size	Unit	Access rule	Mandatory	Announcement at status change	Remark
		Value range (decimal notation)							
Operation status	0x80	This property indicates the ON/OFF status.	unsigned char	1 byte	—	Set	○	○	
		ON=0x30, OFF=0x31				Get	○		
Set value of room relative humidity	0xB4	Set value of relative humidity at auto ventilating operation.	unsigned char	1 byte	%	Set/Get			
		0x00–0x64, (0–100%)							
Ventilation auto setting	0xBF	Auto/Non-auto	unsigned char	1 byte	–	Set/Get			
		Auto = 0x41, Non-auto = 0x42							
Measured value of room relative humidity	0xBA	Measured value of room relative humidity	unsigned char	1 byte	%	Get			
		0x00–0x64 (0–100%)							
Set value of ventilation air flow rate	0xA0	Sets ventilation air flow rate level and ventilation air flow rate auto status. This property specifies ventilation air flow rate level (8-step).	unsigned char	1 byte	–	Set/Get			
		Ventilation air flow rate auto status = 0x41 Ventilation air flow rate level = 0x31–0x38							
Heat exchanger operation setting	0xE0	This property indicates ON/OFF status of heat exchanger.	unsigned char	1 byte	–	Set/Get			
		Heat exchanger ON = 0x41, OFF=0x42							
Measured value of CO ₂ concentration	0xC0	This property indicates measured value of CO ₂ concentration in ppm.	unsigned short	2 bytes	ppm	Get			
		0x0000–0xFFFFD (0–65533 ppm)							
Smoke (cigarette) detection status	0xC1	This property indicates smoke (cigarette) detection status.	unsigned char	1 byte	–	Get			
		Smoke (cigarette) detection status found = 0x41 Smoke (cigarette) detection status not found = 0x42							
Pollution detection status	0xC2	This property indicates pollution detection status	unsigned char	1 byte	–	Get			
		Pollution detected = 0x41 Pollution non-detected = 0x42							

Note: In the “Announcement at status change” column, ○ denotes mandatory processing when the property is implemented.

(1) Operation status (inherited from the device object super class property)

This property indicates the operation/stop status of the air conditioner. The property value of 0x30/0x31 shall be associated with both operation and stop.

(2) Set value of room relative humidity

Sets the set value of room relative humidity in the auto ventilating operation in %. If the measured value of room relative humidity exceeds the set value of room relative humidity when the “ventilation auto status” is set to Auto, the “operation status” switches to ON. The property value range shall be 0x00 to 0x64 (0 to 100%). When the property value of the actual device exceeds the property value range, the overflow code 0xFF shall be used. When the property value falls below the property value range, the underflow code 0xFE shall be used.

(3) Ventilation auto setting

Sets either Auto or Non-auto for the auto ventilating operation.

Auto = 0x41, Non-auto = 0x42

(4) Measured value of room relative humidity

Sets the measured value of room relative humidity in %. The property value range shall be 0x00 to 0x64 (0 to 100%). When the property value of the actual device is higher than the property value range, the overflow code 0xFF shall be used. When the property value is lower than the property value range, the underflow code 0xFE shall be used.

(5) Set value of ventilation air flow rate

This property indicates the ventilation air flow rate level and the ventilation air flow rate auto status. The property value of the ventilation air flow rate auto status shall be 0x41. The air flow rate level shall be set (8-step) and take a property value of 0x31 to 0x38. The values for the 8 levels may be defined freely, as long as 0x31 and 0x38 are used for the minimum and maximum air flow rates, respectively.

(6) Heat exchange operation setting

Sets ON/OFF as the operation status of the heat exchange function.

Heat exchange function ON = 0x41, OFF = 0x42

(7) Measured value of CO₂ concentration

This property indicates the measured value of CO₂ concentration in ppm. The property value range shall be 0x0000 to 0xFFFFD (0 to 65533 ppm). When the property value of the actual device is higher than the property value range, the overflow code 0xFFFF shall be used. When the property value is lower than the

property value range, the underflow code 0xFFFE shall be used.

(8) Smoke (cigarette) detection status

This property indicates whether a smoke (cigarette) detection status is found or not. “Smoke (cigarette) detection status found” shall be 0x41 and “Smoke (cigarette) detection status not found” shall be 0x42.

3. 2. 4 Requirements for air cleaner class

Class group code : 0x01

Class code : 0x35

Instance code : 0x01–0x7F (0x00: All-instance specification code)

Property name	EPC	Contents of property	Data type	Data size	Unit	Access rule	Mandatory	Announcement at status change	Remark
		Value range (decimal notation)							
Operation status	0x80	This property indicates the ON/OFF status.	unsigned char	1 byte	—	Set	○	○	
		ON=0x30, OFF=0x31							
Filter change notice	0xE1	Filter change time notice found/not found	unsigned char	1 byte	–	Get			
		Found = 0x41, Not found = 0x42							
Air flow rate setting	0xA0	Sets air flow rate level and air flow rate auto status. The ventilation air flow rate is specified (8-step).	unsigned char	1 byte	–	Set/Get			
		Ventilation air flow rate auto status = 0x41 Ventilation air flow rate level = 0x31–0x38							
Smoke (cigarette) detection status	0xC1	This property indicates smoke (cigarette) detection status.	unsigned char	1 byte	–	Get			
		Smoke (cigarette) detection status found = 0x41 Smoke (cigarette) detection status not found = 0x42							
Optical catalyst operation setting	0xC2	Optical catalyst ON/OFF status	unsigned char	1 byte	–	Set/Get			
		Optical catalyst ON = 0x41 Optical catalyst OFF = 0x42							
Air pollution detection status	0xC0	This property indicates air pollution detection status	unsigned char	1 byte	–	Get			
		Air pollution detected = 0x41 Air pollution non-detected = 0x42							

Note: In the “Announcement at status change” column, ○ denotes mandatory processing when the property is implemented.

(1) Operation status (inherited from the device object super class property)

This property indicates the operation/stop status of the air cleaner. The property value of 0x30/0x31 shall be associated with both operation and stop.

(2) Filter change notice

This property indicates whether notification of filter change is to be made or not. This property shall disclose that the time has come to change the air cleaner filter. The transition from “Filter change time notice found” to “Filter change time notice not found” shall be achievable using the reset switch on the air cleaner body, etc.

Found = 0x41, not found = 0x42

(3) Air flow rate setting

This property indicates the air flow rate level and air flow rate auto status. The property value of the air flow rate auto status shall be 0x41. The air flow rate level shall be set (8-step) and take a property value of 0x31 to 0x38. The values for the 8 levels may be defined freely, as long as 0x31 and 0x38 are used for the minimum and maximum air flow rates, respectively.

(4) Smoke (cigarette) detection status

This property indicates whether smoke (cigarette) detection status is found or not. “Smoke (cigarette) detection status found” = 0x41 and “Smoke (cigarette) detection status not found” = 0x42 shall be specified.

(5) Optical catalyst operation setting

This property indicates the operation status of the optical catalyst function as ON/OFF. “Optical catalyst ON” = 0x41 and “Optical catalyst OFF” = 0x42 shall be specified.

(6) Air pollution detection status

This property indicates air pollution detection status. Air pollution detected = 0x41 and Air pollution non-detected = 0x42 shall be specified.

3. 2. 5 Requirements for humidifier class

Class group code : 0x01

Class code : 0x39

Instance code : 0x01–0x7F (0x00: All-instance specification code)

Property name	EPC	Contents of property	Data type	Data size	Unit	Access rule	Mandatory	Announcement at status change	Remark
		Value range (decimal notation)							
Operation status	0x80	This property indicates the ON/OFF status.	unsigned char	1 byte	—	Set	○	○	
		ON=0x30, OFF=0x31				Get	○		
Humidifying setting 1	0xC0	Sets value of relative humidity and get setting status	unsigned char	1 byte		Set/Get	○		Note1
		0x00–0x64, (0–100%) Automatic setting =0x70, Continuous operation =0x71, intermittent operation =0x72							
Humidifying setting 2	0xC1	Sets humidifying level by 3 steps	unsigned char	1 byte		Set/Get	○		Note1
		Humidifying levels =0x31–0x33 Automatic setting =0x70, Continuous operation =0x71, intermittent operation =0x72							
Measured value of relative humidity	0xB4	This property indicates measured value of relative humidity	unsigned char	1 byte	–	Get			
		0x00–0x64, (0–100%)							
Reservation set of OFF timer	0x94	Sets reservation ON/OFF and set setting status	unsigned char	1 byte		Set/Get			
		Reservation ON =0x41, OFF =0x42							
Relative time value set of OFF timer	0x96	Sets timer value HH:MM and get updated time	unsigned char ×2	2 bytes		Set/Get			
		Reservation ON =0x41, OFF =0x42							
Ion emission setting	0xC2	Sets ON/OFF of ion emission and gets setting status	unsigned char	1 byte	–	Set/Get			
		Emission ON= 0x41, OFF=0x42							
Implemented ion emission method	0xC3	Sets ion emission method equipped in humidifier by bit map	unsigned char	1 byte	–	Get			
		Bit 0: negative ion method, Bit 1: cluster ion method,							
Special operation mode setting	0xC4	Sets special operation mode and gets setting status. Specifies by bit map	unsigned short	1 byte		Set/Get			
		Specifies 1 for effective setting Bit 0: Throat dry prevention Bit 1: Quiet operation Bit 2–7: for future reserved							
Water amount level	0xC5	This property indicates water amount level in water tank by 6 steps.	unsigned char	1 byte	–	Get			
		0x40: empty 0x41–0x45: minimum to maximum level							

Note: In the “Announcement at status change” column, ○ denotes mandatory processing when the property is implemented.

Note1: Either the “humidifying setting 1” or “humidifying setting 2” property must be implemented.

(1) Operation status (inherited from super class property)

Sets operation ON/OFF of humidifier and gets operation status. Operation ON/OFF corresponds to 0x30/0x31 respectively. For humidifiers, access rule “Set” must be implemented.

(2) Humidifying setting 1

Sets relative humidity and continuous operation status and gets setting status. Relative humidity is set in the unit of % and the humidifier is operated according to the property value as a target.

Furthermore, the property value when an automatic humidity detection algorithm of humidifier determines the target is 0x70, the property value of continuous operation is 0x71 and the property value of intermittent operation at a specified interval is 0x72.

Detailed intermittent operation interval is not specified. Either the humidifying set 1 or the humidifying set 2 is mandatory to be implemented.

(3) Humidifying set 2

Sets humidifying level and continuous operation status, and gets setting status.

Humidifying levels are decided by 3 steps and take the property values of 0x31 to 0x 33. Each value of the humidifying level is not specified. The minimum humidifying is 0x31 and the maximum humidifying is 0x33.

The property value when the target value is automatically decided by calculation algorithm for automatic humidity setting value of the humidifier is 0x70. The property value when the humidifier is operated continuously is 0x71. The property value when the humidifier is operated off and on at a specified interval is 0x72. The details of operation interval are not specified when the humidifier is operated off and on.

Either “Humidifying setting 1” or “Humidifying setting 2” is mandatorily implemented.

(4) Measured value of relative humidity

Expresses a measured value of relative humidity in unit of %. The value range of property is 0x00 to 0x64(100%). When the property value of actual equipment is over the value range of property, an overflow code 0xFF is used. When the property value is less than the value range of property, an underflow code 0xFE is used. When a measurement value cannot be returned, a code 0xFD is used.

(5) Reservation setting of OFF timer

Sets on/off of an OFF timer and gets setting status. The property is related to “Relative time value setting of OFF timer”. Reservation setting ON=0x41, reservation setting OFF=0x42.

(6) Relative time value setting of OFF timer

Sets the time when the humidifier turn to OFF and gets updated time when “Reservation setting of OFF timer” is ON. The data format is hour: 0x00-0x17 (0-23minutes) and minute: 0x00-0x3B (0-59). The property value is taken from the upper bytes in the order of hour and minute.

(7) Ion emission setting

Sets ON/OFF of ion emitting function implemented in humidifier and gets setting status. Ion emitting ON=0x41, ion emitting OFF=0x42.

(8) Implemented ion emission method

Expresses implemented method of ion emission functions by a bit map. As realizing methods, negative ion method and cluster ion method are specified. The details are as follows. The bit 0 means that the realizing method is not implemented, and bit 1 means that the realizing method is implemented.

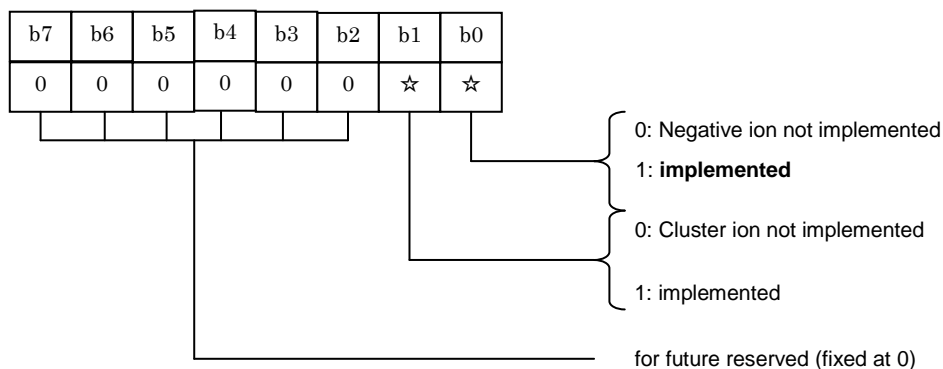

(9) Water amount level

Expresses an amount of water remained in the tank by 6 steps. Each value of level is not specified. The empty status is 0x40 and full maximum amount status is 0x45.

3. 2. 6 Requirements for electric heater class

Class group code : 0x01

Class code : 0x42

Instance code : 0x01–0x7F (0x00: All-instance specification code)

Property name	EPC	Contents of property	Data type	Data size	Unit	Access rule	Mandatory	Announcement at status change	Remark
		Value range (decimal notation)							
Operation status	0x80	This property indicates the ON/OFF status.	unsigned char	1 byte	—	Set		○	
		ON=0x30, OFF=0x31				Get			
Automatic temperature control setting	0xB1	Used to specify whether or not to use the automatic temperature control function.	unsigned char	1 byte	–	Set/Get			
		Automatic = 0x41, non-automatic = 0x42							
Temperature setting	0xB3	Used to set the temperature.	unsigned char	1 byte	°C	Set/Get	○		
		0x00–0x32 (0–50°C)							
Measured room temperature	0xBB	This property indicates the measured room temperature.	signed char	1 byte	°C	Get			
		0x81–0x7E (-128–127°C)							
Remotely set temperature	0xBC	This property indicates the last temperature (°C) set by the user using a remote controller unit.	unsigned char	1 byte	°C	Get			
		0x00–0x32 (0–50°C)							
Air flow rate setting	0xA0	Used to specify the air flow rate or to specify using the function to automatically control the air flow rate. The air flow rate is selected from among the 8 predefined levels.	unsigned char	1 byte	–	Set/Get			
		Automatic air flow rate control used = 0x41 Air flow rate = 0x31 to 0x38							
ON timer-based reservation setting	0x90	Used to specify whether or not to use the ON timer-based reservation function.	unsigned char	1 byte	–	Set/Get			
		ON timer-based reservation function ON: 0x41 ON timer-based reservation function OFF: 0x42							
ON timer setting (time)	0x91	Used to specify the time for the ON timer-based reservation function in the HH:MM format.	unsigned char × 2	2 bytes	–	Set/Get			
		0–0x17: 0–0x3B (= 0–23): (= 0–59)							
ON timer setting (relative time)	0x92	Used to specify the relative time for the ON timer-based reservation function in the HH:MM format	unsigned char × 2	2 bytes	–	Set/Get			
		0–0x17: 0–0x3B (= 0–23): (= 0–59)							

OFF timer-based reservation setting	0x94	Used to specify whether or not to use the OFF timer-based reservation function.	unsigned char	1 byte	-	Set/Get			
		OFF timer-based reservation function ON: 0x41 OFF timer-based reservation function OFF: 0x42							
OFF timer setting (time)	0x95	Used to specify the time for the OFF timer-based reservation function in the HH:MM format.	unsigned char × 2	2 bytes	-	Set/Get			
		0-0x17: 0-0x3B (= 0-23): (= 0-59)							
Set value of OFF timer relative time	0x96	Timer value HH:MM	unsigned char × 2	2 bytes	-	Set/Get			
		0-0x17: 0-0x3B (= 0-23): (= 0-59)							

Note: In the “Announcement at status change” column, ○ denotes mandatory processing when the property is implemented.

(1) Operation status (inherited from the device object super class property)

This property indicates the operation/stop status of the electric heater. The property value of 0x30/0x31 shall be associated with both operation and stop.

(2) Automatic temperature control setting

This property indicates the operation status ON/OFF setting when the electric heater is operated by the auto temperature setting calculation algorithm of the electric heater body without using “Set temperature value” (EPC = 0xB3) as the target value. This property shall take 0x41 for auto status ON and 0x42 for auto status OFF.

(3) Temperature setting

This property indicates the set temperature value in the current “operation mode” in °C. If the electric heater does not have the “temperature auto setting” function, or if the electric heater having the “temperature auto setting” function is placed in the “non-auto” (0x42) state, the electric heater operates on the assumption that the value of this property is the target temperature value. If the target temperature value indicated by this property is unknown when the “temperature auto setting” function is placed in the “auto” state, this property shall take the value 0xFD (set temperature value unknown).

(4) Measured room temperature

This property indicates the measured value of the room temperature in °C. The property value range shall be 0x81 to 0x7E (-127 to 126°C). When the property value of the actual device is higher than the property value range, the overflow code 0x80 shall be used. When the property value is lower than the property value range, the underflow code 0x7E shall be used.

(5) Remotely set temperature

This property indicates the last temperature (°C) set by the user using a remote controller unit. This property is used for reference purposes after changing the temperature setting for the electric heater by means of a controller, etc.

(6) Air flow rate setting

Used to specify the air flow rate or to specify using the function to automatically control the air flow rate. The air flow rate shall be selected from among the 8 levels predefined in the 0x31 to 0x38 range. When the automatic air flow rate control function is used, the property value shall be 0x41. The air flow rate values for the 8 levels may be defined freely, as long as 0x31 and 0x38 are used for the minimum and maximum air flow rates, respectively.

(7) ON timer-based reservation setting

Sets the reservation ON/OFF of the ON timer. This property is related to the “Set value of ON timer time” or “Set value of ON timer relative time”.

Reservation ON = 0x41, reservation OFF = 0x42

(8) ON timer setting (time)

This property indicates the electric heater ON time with “ON timer reservation status” ON by hour: 0x00 to 0x17 (0 to 23) and minute: 0x00 to 0x3B (0 to 59). The property shall begin with the high-order byte in the order of hour, minute.

(9) ON timer setting (relative time)

This property indicates the electric heater ON time with “ON timer time reservation status” ON by the relative time from the current time. The data format shall be hour: 0x00 to 0x17 (0 to 23) and minute: 0x00 to 0x3B (0 to 59), and the property value shall begin with the high-order byte in the order of hour, minute.

(10) OFF timer-based reservation setting

Sets the reservation ON/OFF of the OFF timer. This property is associated with the “Set value of OFF timer time” or “Set value of OFF timer relative time”.

Reservation ON = 0x41, reservation OFF = 0x42

(11) OFF timer setting (time)

This property indicates the air conditioner OFF time with “OFF timer reservation status” ON by hour: 0x00 to 0x17 (0 to 23) and minute: 0x00 to 0x3B (0 to 59). The

property value shall begin with the high-order byte in the order of hour, minute.

(12) Set value of OFF timer relative time

This property indicates the air conditioner OFF time by the relative time from the current time with “OFF timer reservation status” ON. The data format shall be hour: 0x00 to 0x17 (2 to 23) and minute: 0x00 to 0x3B (0 to 59). The property value shall begin with the high-order byte in the order of hour, minute.

3. 2. 7 Requirements for Fan heater class

Class group code : 0x01

Class code : 0x43

Instance code : 0x01-0x7F (0x00: All-instance specification code)

Property name	EPC	Contents of property	Data type	Data size	Unit	Access rule	Mandatory	Announcement at status change	Remark
		Value range (decimal notation)							
Operation status	0x80	This property indicates the ON/OFF status.	unsigned char	1 byte	—	Set	○	○	
		ON=0x30, OFF=0x31				Get	○		
Temperature setting value	0xB3	Sets the temperature and gets the setting status.	unsigned char	1 byte	°C	Set/Get	○		
		0x00-0x32 (0-50°C)							
Measured temperature	0xBB	This property indicates the measured room temperature.	signed char	1 byte	°C	Get			
		0x81-0x7D (-128-125°C)							
Automatic temperature control setting	0xB1	Sets automatic/non-automatic and gets the setting status	unsigned char	1 byte	-	Set/Get			
		Automatic = 0x41, non-automatic = 0x42							
ON timer reservation setting	0x90	Sets ON/OFF of reservation and gets the setting status.	unsigned char	1 byte	-	Set/Get			
		Reservation ON: 0x41, OFF:0x42 for both time and relative time Timer-based reservation ON:0x43, Relative time reservation ON:0x44							
ON timer setting value (time)	0x91	Sets timer value HH:MM and gets setting status	unsigned char × 2	2 bytes	-	Set/Get			
		0-0x17: 0-0x3B (= 0-23): (= 0-59)							
ON timer setting value (relative time)	0x92	Sets timer value HH:MM and gets the updated time	unsigned char × 2	2 bytes	-	Set/Get			
		0-0x17: 0-0x3B (= 0-23): (= 0-59)							
OFF timer reservation setting	0x94	Sets ON/OFF of reservation and gets setting status	unsigned char	1 byte	-	Set/Get			
		Reservation ON: 0x41, OFF:0x42 for both time and relative time Timer-based reservation ON:0x43, Relative time reservation ON:0x44							
OFF timer setting value (time)	0x95	Sets timer value HH:MM and gets the setting status.	unsigned char × 2	2 bytes	-	Set/Get			
		0-0x17: 0-0x3B (= 0-23): (= 0-59)							
OFF timer value (relative time)	0x96	Sets timer value HH:MM and gets updated time	unsigned char × 2	2 bytes	-	Set/Get			
		0-0x17: 0-0x3B (= 0-23):(= 0-59)							

Extensional operation setting	0xC0	Sets ON/OFF of extensional operation and gets setting status.	unsigned char	1 byte	-	Set/Get			
		Extension ON=0x41, OFF=0x42							
Extensional operation timer time setting value	0xC1	Sets extension time HH:MM and gets the extended time	unsigned char × 2	2 byte	-	Set/Get			
		0-0x17: 0-0x3B (= 0-23):(= 0-59)							
Ion emission setting	0xC2	Sets ON/OFF of ion emission and gets setting status.	unsigned char	1 byte	-	Set/Get			
		Emission ON=0x41, OFF=0x42							
Implemented ion emission method	0xC3	Specifies ion emission method implemented in humidifier by bit map	unsigned char	1 byte	-	Get			
		Extension ON=0x41, OFF=0x42							
Oil amount level	0xC4	Specifies oil amount in the tank by 6 levels.	unsigned char	1 byte	-	Get			
		0x40: empty 0x41-0x45: minimum to maximum levels							

Note: In the “Announcement at status change” column, ○ denotes mandatory processing when the property is implemented.

- (1) Operation status (inherited from the device object super class property)
 Sets the operation/stop status of the fan heater. The property value of 0x30/0x31 shall be associated with both operation and stop. The access rule “Set” must be implemented for fan heaters.
- (2) Temperature setting value
 Sets the temperature value in °C and gets the setting status. The fan heater operates as a target of the property value.
- (3) Measured room temperature
 This property indicates the measured value of the room temperature in °C. The property value range shall be 0x81 to 0x7D. When the property value of the actual device is higher than the property value range, the overflow code 0x7F shall be used. When the property value is lower than the property value range, the underflow code 0x80 shall be used. When a measured temperature cannot be obtained, the code 0x7E shall be used.
- (4) Automatic temperature control setting
 Sets the operation status ON/OFF when the fan heater is operated by the auto temperature setting calculation algorithm of the fan heater body without using “Set temperature value” (EPC = 0xB3) as the target value. This property shall take 0x41 for auto status ON and 0x42 for auto status OFF.

(5) ON timer reservation setting

Sets the reservation ON/OFF of the ON timer and gets the setting value. This property is related to the “Set value of ON timer time” or “Set value of ON timer relative time”.

Reservation ON = 0x41, reservation OFF = 0x42

(6) ON timer setting value (time)

This property indicates the fan heater ON time with “ON timer reservation status” ON by hour: 0x00 to 0x17 (0 to 23) and minute: 0x00 to 0x3B (0 to 59). The property shall begin with the high-order byte in the order of hour, minute.

(7) ON timer setting value (relative time)

This property indicates the fan heater ON time with “ON timer reservation status” ON by the relative time from the current time. The data format shall be hour: 0x00 to 0x17 (0 to 23) and minute: 0x00 to 0x3B (0 to 59), and the property value shall begin with the high-order byte in the order of hour, minute.

(8) OFF timer reservation setting

Sets the reservation ON/OFF of the OFF timer. This property is associated with the “Set OFF timer time value” or “Set OFF timer relative time value”.

Reservation ON = 0x41, reservation OFF = 0x42 for both time reservation and relative time reservation. ON=0x43 for only time reservation, and ON=0x44 for only relative time reservation.

(9) OFF timer setting value (time)

Sets the fan heater OFF time with “OFF timer reservation status” ON by hour: 0x00 to 0x17 (0 to 23) and minute: 0x00 to 0x3B (0 to 59). The property value shall begin with the high-order byte in the order of hour, minute.

(10) OFF timer setting value (relative time)

Sets the fan heater OFF time by the relative time from the current time with “OFF timer reservation status” ON. The data format shall be hour: 0x00 to 0x17 (2 to 23) and minute: 0x00 to 0x3B (0 to 59). The property value shall begin with the high-order byte in the order of hour, minute.

(11) Extensional operation setting

Sets ON/OFF of the extensional operation and gets the operation status when the operation status (0x80) is ON (0x30). The property has relation to “Extensional

timer time setting value”. Extensional operation ON=0x41, extensional operation OFF=0x42.

(12) Extensional operation timer time setting

Sets the operation time of the fan heater by relative time from the current time when “extensional operation setting” is ON. The data format shall be hour: 0x00 to 0x17 (2 to 23) and minute: 0x00 to 0x3B (0 to 59). The property value shall begin with the high-order byte in the order of hour, minute.

(13) Ion emission setting

Sets ON/OFF of the ion emission function implemented in the fan heater, and gets the setting status. Ion emission ON=0x41, Ion emission OFF=0x42.

(14) Implemented ion emission method

Expresses the implemented method of ion emission functions by a bit map. As realizing methods, negative ion method and cluster ion method are specified. The details are as follows. The bit 0 means that the realizing method is not implemented, and bit 1 means that the realizing method is implemented.

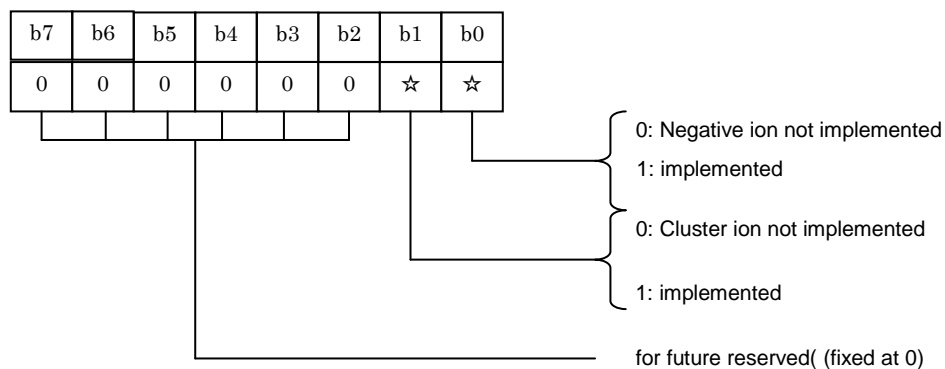

(15) Oil amount level

Expresses an amount of oil remained in the tank by 6 steps. Each value of level is not specified. The empty status is 0x40 and full maximum amount status is 0x45.

3. 2. 8 Requirements for package-type commercial air conditioner (indoor unit) class

Class group code : 0x01

Class code : 0x45

Instance code : 0x01 to 0x7F (0x00: All-instance specification code)

Property name	EPC	Contents of property	Data type	Data size	Unit	Access rule	Mandatory	Announcement at status change	Remark
		Value range (decimal notation)							
Operation status	0x80	This property indicates the ON/OFF status.	unsigned char	1 byte	—	Set	○	○	
		ON=0x30, OFF=0x31				Get	○		
Operation mode setting	0xB0	Used to specify the operation mode (“automatic,” “cooling,” “heating,” “dehumidification” or “air circulator”) and to acquire the current setting.	unsigned char	1 byte		Set/Get	○	○	
		The following values shall be used: Automatic: 0x41 Cooling: 0x42 Heating: 0x43 Dehumidification: 0x44 Air circulator: 0x45							
Temperature setting 1	0xB3	Used to set the temperature and to acquire the current setting.	signed char	1 byte	1°C	Set/Get	○	○	Note1
		0x00–0x32 (0–50°C)							
“Relative humidity setting for ‘dehumidification’ mode” 1	0xB4	Used to set the relative humidity for the “dehumidification” mode and to acquire the current setting.	unsigned char	1 byte	1%	Set/Get		○	
		0x00–0x64 (0–100%)							
“Temperature setting for ‘cooling’ mode” 1	0xB5	Used to set the temperature for the “cooling” mode and to acquire the current setting.	signed char	1 byte	1°C	Set/Get			
		0x00–0x32 (0–50°C)							
“Temperature setting for ‘heating’ mode” 1	0xB6	Used to set the temperature for the “heating” mode and to acquire the current setting.	signed char	1 byte	1°C	Set/Get			
		0x00–0x32 (0–50°C)							
“Temperature setting for ‘dehumidification’ mode” 1	0xB7	Used to set the temperature for the “dehumidification” mode and to acquire the current setting.	signed char	1 byte	1°C	Set/Get			
		0x00–0x32 (0–50°C)							
Rated power consumption of indoor unit	0xB8	This property indicates the rated power consumption for the cooling, heating, dehumidification and air circulator modes.	unsigned short × 4	8 bytes	W	Get			
		0x0000–0xFFFD (0–65533W) Cooling: heating: dehumidification: air circulator							
Measured electric current	0xB9	This property indicates the measured electric current consumption.	unsigned	2 bytes	0.1A	Get			

consumption of indoor unit		0x0000–0xFFFFD (0–6553.3A)	short						
Measured indoor relative humidity 1	0xBA	Used to acquire the measured indoor relative humidity.	unsigned char	1 byte	1%	Get			
		0x00–0x64 (0–100%)							
Measured indoor temperature 1	0xBB	Used to acquire the measured indoor temperature.	signed char	1 byte	1°C	Get			
		0x81–0x7D (-127–125°C)							
Relative temperature setting	0xBF	Used to set the relative temperature relative to the target temperature for an air conditioner operation mode and to acquire the current setting.	signed char	1 byte	0.1°C	Set/Get			
		0x81–0x7D (-12.7°C–12.5°C)							
Air flow rate setting	0xA0	Used to specify the air flow rate or to specify using the function to automatically control the air flow rate, and to acquire the current setting. The air flow rate shall be selected from among the 8 predefined levels.	unsigned char	1 byte		Set/Get			
		Automatic air flow rate control function used = 0x41 Air flow rate = 0x31–0x38							
“Air flow direction (vertical)” setting	0xA4	Used to specify the air flow direction in the vertical plane by selecting a pattern from among the 9 predefined patterns or to specify using the automatic air flow direction control function or automatic air flow swing function, and to acquire the current setting.	unsigned char	1 byte		Set/Get			
		Automatic = 0x31, swing = 0x32 Air flow direction: 0x41–0x49 (0x41 and 0x49 shall be used for the uppermost and lowermost directions, respectively.)							
“Air flow direction (horizontal)” setting	0xA5	Used to specify the air flow direction in the horizontal plane by selecting a pattern from among the 6 predefined patterns or to specify using the automatic air flow direction control function or automatic air flow swing function, and to acquire the current setting.	unsigned char	1 byte		Set/Get			
		Automatic = 0x31, swing = 0x32 Air flow direction: Rightward = 0x41, leftward = 0x42, central = 0x43, rightward and leftward = 0x44							
“Special” state	0xAA	This property indicates when the air conditioner is in a “special” state.	unsigned char	1 byte	–	Get			
		“Normal operation” state = 0x40, “preheating” state = 0x42, “heat removal” state = 0x43							
Thermostat state	0xAC	This property indicates the state (ON or OFF) of the thermostat.	unsigned char	1 byte		Get			
		Thermostat ON = 0x41 Thermostat OFF = 0x42							

Current function (“automatic” operation mode)	0xAE	This property indicates, when the air conditioner is operating in the “automatic” operation mode, the function (“cooling,” “heating,” “dehumidification,” “air circulator” or “other”) that is currently being used.	unsigned char	1 byte		Get		○	
		The following values shall be used: Cooling: 0x42 Heating: 0x43 Dehumidification: 0x44 Air circulator: 0x45 Other: 0x40							
Ventilation mode setting	0xC0	Used to specify the ventilation mode and to acquire the current setting.	unsigned char	1 byte	—	Set/Get			
		Ordinary ventilation = 0x41, ventilation plus total heat exchanger-based heat exchange = 0x42, automatic control of ventilation (i.e. automatic switching between ordinary ventilation and ventilation plus total heat exchanger-based heat exchange) = 0x43							
Combined operation of indoor unit and total heat exchanger	0xC1	Used to specify whether or not to use the “combined operation of indoor unit and total heat exchanger” function, and to acquire the current setting.	unsigned char	1 byte	—	Set/Get			
		“Combined operation of indoor unit and total heat exchanger” function used = 0x41 “Combined operation of indoor unit and total heat exchanger” function not used= 0x42							
Ventilation air flow rate setting	0xC2	Used to specify the ventilation air flow rate by selecting a level from among the predefined levels and to acquire the current setting.	unsigned char	1 byte	—	Set/Get			
		Automatic control of ventilation air flow rate = 0x41 Ventilation air flow rate = 0x31 to 0x38							
“Disabling of air conditioner” setting	0xCD	Used to specify whether or not to disable the air conditioner, and to acquire the current setting.	unsigned char	1 byte		Set/Get			
		Disabled = 0x41, not disabled = 0x42							
Thermostat setting override function	0xCE	Used to specify whether or not the air conditioner shall operate ignoring its thermostat setting.	unsigned char	1 byte		Set/Get			
		Normal setting = 0x40, thermostat setting override function ON = 0x41, thermostat setting override function OFF = 0x42							
Filter cleaning reminder lamp setting	0xCF	Used to specify whether or not to enable the filter cleaning reminder lamp, and to acquire the current setting.	unsigned char	1 byte		Set/Get		○	
		Enabled = 0x41, disabled = 0x42							
Measured power consumption of indoor unit	0xDB	This property indicates the measured power consumption of the indoor unit.	unsigned short	2 bytes	W	Get			
		0x0000–0xFFFFD (0–65533W)							

Aperture of expansion valve	0xDC	This property indicates the aperture of the expansion valve in %. 0-0x64 (0-100%)	unsigned char	1 byte	%	Get			
Temperature setting 2	0xE3	Used to set the temperature and to acquire the current setting. 0xFE0C-0x3E8 (-50.0-100.0°C)	unsigned short	2 bytes	0.1°C	Set/Get	○	○	Note1
“Relative humidity setting for ‘dehumidification’ mode” 2	0xE4	Used to set the relative humidity for the “dehumidification” mode and to acquire the current setting. 0x0000-0x3E8 (0.0-100.0%)	unsigned short	2 bytes	0.1%	Set/Get		○	
“Temperature setting for ‘cooling’ mode” 2	0xE5	Used to set the temperature for the “cooling” mode and to acquire the current setting. 0xFE0C-0x3E8 (-50.0-100.0°C)	unsigned short	2 bytes	0.1°C	Set/Get			
“Temperature setting for ‘heating’ mode” 2	0xE6	Used to set the temperature for the “heating” mode and to acquire the current setting. 0xFE0C-0x3E8 (-50.0-100.0°C)	unsigned short	2 bytes	0.1°C	Set/Get			
“Temperature setting for ‘dehumidification’ mode” 2	0xE7	Used to set the temperature for the “dehumidification” mode and to acquire the current setting. 0xFE0C-0x3E8 (-50.0-100.0°C)	unsigned short	2 bytes	0.1°C	Set/Get			
Measured indoor relative humidity 2	0xEA	Used to acquire the measured indoor relative humidity. 0x0000-0x3E8 (0.0-100.0%)	unsigned short	2 bytes	0.1%	Get			
Measured indoor temperature 2	0xEB	Used to acquire the measured indoor temperature. 0xF554-0x7FFD (-273,2-3276,5°C)	unsigned short	2 bytes	0.1°C	Get			
“ON timer-based reservation” setting	0x90	Used to specify whether or not to use the ON timer (time-based reservation function, relative time-based reservation function or both), and to acquire the current setting. Both the time- and relative time-based reservation functions are ON = 0x41, both reservation functions are OFF = 0x42, time-based reservation function is ON = 0x43, relative time-based reservation function is ON = 0x44	unsigned char	1 byte	—	Set/Get			
ON timer setting (time)	0x91	Used to specify the time for the time-based reservation function in the HH:MM format and to acquire the current setting. 0-0x17: 0-0x3B (= 0-23): (= 0-59)	unsigned char × 2	2 bytes	—	Set/Get			
ON timer setting (relative time)	0x92	Used to specify the relative time for the relative time-based reservation function in the HH:MM format and to acquire the current setting. 0-0xFF: 0-0x3B (= 0-255): (= 0-59)	unsigned char × 2	2 bytes	—	Set/Get			
“OFF timer-based reservation” setting	0x94	Used to specify whether or not to use the OFF timer (time-based reservation function, relative time-based reservation function or both), and to acquire the current setting.	unsigned char	1 bytes	—	Set/Get			

		Both the time- and relative time-based reservation functions are ON = 0x41, both reservation functions are OFF = 0x42, time-based reservation function is ON = 0x43, relative time-based reservation function is ON = 0x44							
OFF timer setting (time)	0x95	Used to specify the time for the time-based reservation function in the HH:MM format and to acquire the current setting. 0-0x17: 0-0x3B (= 0-23): (= 0-59)	unsigned char × 2	2 bytes	—	Set/Get			
OFF timer setting (relative time)	0x96	Used to specify the relative time for the relative time-based reservation function in the HH:MM format and to acquire the current setting. 0-0xFF: 0-0x3B (= 0-255): (= 0-59)	unsigned char × 2	2 bytes	—	Set/Get			

Note: In the “Announcement at status change” column, ○ denotes mandatory processing when the property is implemented.

Note1: Either the “temperature setting 1” property (0xB3) or “temperature setting 2” property (0xE3) must be implemented.

<Communication definition class setting examples (Communication definition objects are excluded because they are not defined in the ECHONET Lite.)>

- Example 1: When it is necessary to totally or partly disable the controls on the main unit side (remote control, etc.) for a mode specified by the “operation mode setting” property (0xB0), the “local control limit setting” communication definition class is used.
- Example 2: When the piece of equipment is designed to allow modifications to the setting of the “Temperature setting for cooling mode’ 1” property (0xB5), the “network control limit status display” communication definition class is used.

(1) Operation status (inherited from the device super class property)

Used to specify whether to turn on or off the package-type commercial air conditioner (indoor unit), and to acquire the current operation status. 0x30 and 0x31 shall be used for the ON and OFF states, respectively.

(2) Operation mode setting

Used to specify the operation mode of the package-type commercial air conditioner (indoor unit) (“automatic,” “cooling,” “heating,” “dehumidification” or “air circulator”) and to acquire the current setting. 0x41, 0x42, 0x43, 0x44 and 0x45 shall be used for “automatic,” “cooling,” “heating,” “dehumidification” and “air circulator,” respectively.

It is only required to implement the property values that correspond to the functions provided by the actual piece of equipment in which this class is implemented. For example, if the piece of equipment in which this class is implemented does not have an air circulator function, it is not necessary to implement the value for the air circulator mode (0x45).

This property shall be effective even when the value of the “operation status” property (0x80) is OFF (0x31).

(3) Temperature setting 1

Used to set the temperature (in 1°C increments) for the current operation mode of the indoor unit that is specified by the “operation mode setting” property, and to acquire the current setting. The air conditioner shall use the value of this property as the target temperature.

This property shall be effective even when the value of the “operation status” property (0x80) is OFF (0x31).

(4) “Relative humidity setting for ‘dehumidification’ mode” 1

Used to set the relative humidity (in 1% increments) for the “dehumidification” mode (as specified by the “operation mode setting” property (EPC = 0xB0)), and to acquire the current setting. Implementation of this property allows values to be specified and referenced even when a mode other than the “dehumidification” mode is specified by the “operation mode setting” property (EPC = 0xB0). This property shall be effective even when the value of the “operation status” property (0x80) is OFF (0x31).

(5) “Temperature setting for ‘cooling’ mode” 1

Used to set the temperature (in 1°C increments) for the “cooling” mode (as specified by the “operation mode setting” property (EPC = 0xB0)), and to acquire the current setting. Implementation of this property allows values to be specified and referenced even when a mode other than the “cooling” mode is specified by the “operation mode setting” property (EPC = 0xB0).

The content of this property must match the content of the “temperature setting” property (EPC = 0xB3).

This property shall be effective even when the value of the “operation status” property (0x80) is OFF (0x31).

- (6) “Temperature setting for ‘heating’ mode” 1
Used to set the temperature (in 1°C increments) for the “heating” mode (as specified by the “operation mode setting” property (EPC = 0xB0)), and to acquire the current setting. Implementation of this property allows values to be specified and referenced even when a mode other than the “heating” mode is specified by the “operation mode setting” property (EPC = 0xB0).
The content of this property must match the content of the “temperature setting” property (EPC = 0xB3).
This property shall be effective even when the value of the “operation status” property (0x80) is OFF (0x31).
- (7) “Temperature setting for ‘dehumidification’ mode” 1
Used to set the temperature (in 1°C increments) for the “dehumidification” mode (as specified by the “operation mode setting” property (EPC = 0xB0)), and to acquire the current setting. Implementation of this property allows values to be specified and referenced even when a mode other than the “dehumidification” mode is specified by the “operation mode setting” property (EPC = 0xB0).
The content of this property must match the content of the “temperature setting” property (EPC = 0xB3).
This property shall be effective even when the value of the “operation status” property (0x80) is OFF (0x31).
- (8) Rated power consumption of indoor unit
This property indicates, in watts, the rated power consumption values (brochure values) for the “cooling,” “heating,” “dehumidification” and “air circulator” modes of the indoor unit. The range of rated power consumption value for each of the 4 modes shall be 0x0000 to 0xFFFFD (0 to 65533W) and the bytes shall be used in such a manner that the four values are indicated in the order stated in the previous sentence. When the actual piece of equipment does not support one or more of the four modes, the underflow code 0xFFFFE shall be used for the unsupported mode(s).
This property shall be effective even when the value of the “operation status” property (0x80) is OFF (0x31).
- (9) Measured electric current consumption of the indoor unit
This property indicates the present measured electric current consumption of the indoor unit in 0.1A increments. When the measured electric current is alternating

current, the effective value shall be indicated. The property value range shall be 0x0000 to 0xFFFFD (0 to 6553.3A). When the property value of the actual piece of equipment is higher than the upper limit of the property value range, the overflow code 0xFFFF shall be used. When the property value is lower than the lower limit of the property value range, the underflow code 0xFFFFE shall be used.

(10) Measured indoor relative humidity 1

This property indicates the measured indoor relative humidity in 1% increments. The property value range shall be 0x00 to 0x64 (0 to 100%). When the property value of the actual piece of equipment is higher than the upper limit of the property value range, the overflow code 0xFF shall be used. When the property value is lower than the lower limit of the property value range, the underflow code 0xFE shall be used. When the measurement value cannot be returned, 0xFD shall be used. This property shall be effective even when the value of the “operation status” property (0x80) is OFF (0x31).

(11) Measured indoor temperature 1

This property indicates the measured room temperature in 1°C increments. The property value range shall be 0x81 to 0x7D (-127 to 125°C). When the property value of the actual piece of equipment is higher than the upper limit of the property value range, the overflow code 0x7F shall be used. When the property value is lower than the lower limit of the property value range, the underflow code 0x80 shall be used. When the measurement value cannot be returned, 0x7E shall be used. This property shall be effective even when the value of the “operation status” property (0x80) is OFF (0x31).

(12) Relative temperature setting

Used to specify, in 0.1°C increments, the relative temperature relative to the target temperature (i.e. the temperature differential above or below the target temperature the user wishes to achieve) for an air conditioner operation mode of the package-type commercial air conditioner (indoor unit), and to acquire the current setting. It is also possible to use this property to specify a relative temperature for an operation mode that does not use an absolute value of temperature as the target such as the “automatic” mode. The property value range shall be 0x81 to 0x7D (-12.7 to 12.5°C). 0xF6 shall be used for a differential of 1.0 °C below the target temperature and 0x0A shall be used for a differential of 1.0 °C above the target temperature.

When the property value of the actual piece of equipment is higher than the upper limit of the property value range, the overflow code 0x7F shall be used. When the property value is lower than the lower limit of the property value range, the underflow code 0x80 shall be used. When the setting cannot be returned, 0x7E shall be used.

This property shall be effective even when the value of the “operation status” property (0x80) is OFF (0x31).

(13) Air flow rate setting

Used to specify the air flow rate or to specify using the function to automatically control the air flow rate, and to acquire the current setting. The air flow rate shall be selected from among the 8 levels predefined in the 0x31 to 0x38 range. When the automatic air flow rate control function is used, the property value shall be 0x41. The air flow rate values for the 8 levels may be defined freely, as long as 0x31 and 0x38 are used for the minimum and maximum air flow rates, respectively.

This property shall be effective even when the value of the “operation status” property (0x80) is OFF (0x31).

(14) “Air flow direction (vertical)” setting

Used to specify the air flow direction in the vertical plane by selecting a pattern from among the 9 predefined patterns (0x41 to 0x49) or to specify using the function to automatically swing the air flow in the vertical plane (0x32) or the function to automatically control the air flow direction in the vertical plane (0x31), and to acquire the current setting.

0x41 and 0x49 shall be used for the uppermost and lowermost directions, respectively. 0x42 to 0x48 shall be used for the highest to lowest directions in between the uppermost and lowermost directions. It is recommended that 0x45 be used for the central direction.

It is only required to implement the property values that correspond to the directions supported by the actual piece of equipment in which this class is implemented.

Applicability of this property to the automatic air flow swing function shall be equipment-dependent.

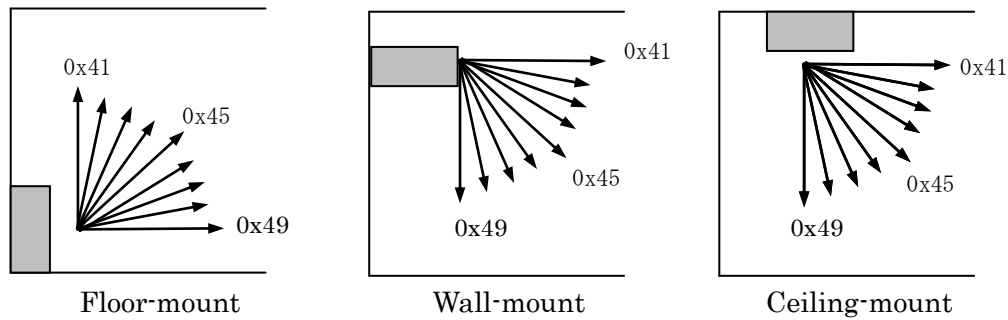

(15) “Air flow direction (horizontal)” setting

Used to specify the air flow direction in the horizontal plane by selecting a pattern from among the predefined patterns (rightward = 0x41, leftward = 0x42, central = 0x43, rightward and leftward = 0x44) or to specify using the function to automatically swing the air flow in the horizontal plane (0x32) or the function to automatically control the air flow direction in the horizontal plane (0x31), and to acquire the current setting.

It is only required to implement the property values that correspond to the directions supported by the actual piece of equipment in which this class is implemented.

Applicability of this property to the automatic air flow swing function shall be equipment-dependent.

(16) “Special” state

This property indicates when the package-type commercial air conditioner is in a “special” state, namely, the “defrosting,” “preheating,” or “heat removal” state.

0x41, 0x42 and 0x43 shall be used for the “defrosting,” “preheating,” and “heat removal” states, respectively. When the air conditioner is in a state other than the “defrosting,” “preheating” and “heat removal” states, 0x40 shall be used.

The “preheating” state shall mean a state in which the compressor is being preheated with the indoor unit fan rotating at a low speed or not rotating, after the heating function is activated or after completion of a defrosting cycle, to allow the air conditioner to supply warm air.

The “heat removal” state shall mean a state in which a fan (the indoor unit fan in most cases) is rotating and the refrigerating cycle is operating to release the residual heat from the air conditioner after the air conditioner is turned off (especially after being used in the heating mode).

This property shall be effective even when the value of the “operation status” property (0x80) is OFF (0x31).

(17) Thermostat state

This property indicates the state (ON or OFF) of the thermostat of the package-type commercial air conditioner (indoor unit). 0x41 and 0x42 shall be used for the ON and OFF states, respectively.

This property shall be effective even when the value of the “operation status” property (0x80) is OFF (0x31).

(18) Current function (“automatic” operation mode)

When “automatic” is specified by the “operation mode setting” property (EPC = 0xB0) for the package-type commercial air conditioner (indoor unit), this property is used to acquire information as to which function (of the actual piece of equipment) is currently being used (i.e. “cooling,” “heating,” “dehumidification,” “air circulator” or “other”). 0x42, 0x43, 0x44, 0x45 and 0x40 shall be used for “cooling,” “heating,” “dehumidification,” “air circulator” and “other,” respectively. “Other” shall mean that the air conditioner is in operation but is not performing any of the “cooling,” “heating,” “dehumidification” and “air circulator” functions.

It is only required to implement the property values that correspond to the functions provided by the actual piece of equipment in which this class is implemented. For example, if the piece of equipment in which this class is implemented does not have an air circulator function, it is not necessary to implement the value for the air circulator function (0x45).

This property shall be effective even when the value of the “operation status” property (0x80) is OFF (0x31).

(19) Ventilation mode setting

Used to specify the ventilation mode (i.e. (a) ordinary ventilation, (b) ventilation plus total heat exchanger-based heat exchange or (c) automatic control of ventilation) of the package-type commercial air conditioner, and to acquire the current setting.

0x41, 0x42 and 0x43 shall be used for (a), (b) and (c), respectively.

This property shall be effective even when the value of the “operation status” property (0x80) is OFF (0x31). The “ordinary ventilation” mode shall mean a ventilation mode in which the air conditioner takes in outdoor air without exchanging heat between the exhaust and supply air. The “ventilation plus total heat exchanger-based heat exchange” mode shall mean a ventilation mode in which the

air conditioner exchanges heat between the exhaust and supply air before it takes in outdoor air. The “automatic control of ventilation” mode shall mean a ventilation mode in which the air conditioner automatically switches between the “ordinary ventilation” and “ventilation plus total heat exchanger-based heat exchange” modes based on the measured indoor and outdoor air temperatures.

(20) Combined operation of indoor unit and total heat exchanger

Used to specify whether or not to use the “combined operation of indoor unit and total heat exchanger” function, and to acquire the current setting.

“Combined operation of indoor unit and total heat exchanger” function used = 0x41

“Combined operation of indoor unit and total heat exchanger” function not used = 0x42

This property shall be effective even when the value of the “operation status” property (0x80) is OFF (0x31).

“Combined operation” (0x43) shall mean combined operation of the indoor unit and total heat exchanger that can be started or stopped in response to a control signal from a single remote controller unit designed to control both the indoor unit and the total heat exchanger.

(21) Ventilation air flow rate setting

Used to specify the ventilation air flow rate by selecting a level from among the 8 predefined levels (0x31 to 0x38) or to specify using the function to automatically control the ventilation air flow rate (0x41 = automatic ventilation air flow rate control used), and to acquire the current setting.

The ventilation air flow rate values for the 8 levels may be defined freely, as long as 0x31 and 0x38 are used for the minimum and maximum ventilation air flow rates, respectively.

This property shall be effective even when the value of the “operation status” property (0x80) is OFF (0x31).

(22) “Disabling of air conditioner” setting

Used to specify whether or not to disable the package-type commercial air conditioner (indoor unit), and to acquire the current setting.

0x41 and 0x42 shall be used for the “disabled” and “not disabled” states, respectively.

When 0x41 (disabled) is selected as the value of this property, the value of the

“operation status” property (EPC = 0x80) shall change to 0x31 (OFF) (unless the “operation status” property already contains “0x31”) and the air conditioner shall remain disabled (after being placed out of operation if it was in operation) and shall ignore all signals from the remote controller and all instructions to switch back to the “not disabled” state including “operation status” property (EPC = 0x80) settings. When the value of this property is changed from 0x41 (disabled) to 0x42 (not disabled), the air conditioner shall be switched from the “disabled” state to be ready to operate as instructed by signals from the remote controller or as specified by the “operation status” property (EPC = 0x80) or by other applicable means (This will not place back into operation an air conditioner that has stopped operating). This property shall be effective even when the value of the “operation status” property (0x80) is OFF (0x31).

(23) Thermostat setting override function

Used to specify whether or not the package-type commercial air conditioner (indoor unit) shall operate ignoring its thermostat setting, and to acquire the current setting. Normal setting = 0x40, thermostat setting override function ON = 0x41, thermostat setting override function OFF = 0x42

The “normal setting” mode is a mode in which the air conditioner is dynamically and automatically switched from the “thermostat ON” state to the “thermostat OFF” state or from the “thermostat OFF” state to the “thermostat ON” state as appropriate depending on the room and outdoor temperatures (The air conditioner remains in operation even after it is switched to the “thermostat OFF” state). The “thermostat setting override function ON” mode is a mode in which the air conditioner continues performing heat exchange ignoring the temperature setting. The “thermostat setting override function OFF” mode is a mode in which the air conditioner performs no heat exchange regardless of the temperature setting. This property shall be effective even when the value of the “operation status” property (0x80) is OFF (0x31).

(24) Filter cleaning reminder lamp setting

Used to specify whether or not to enable the filter cleaning reminder lamp of the package-type commercial air conditioner (indoor unit), and to acquire the current setting.

Filter cleaning reminder lamp enabled = 0x41

Filter cleaning reminder lamp disabled = 0x42

This property shall be effective even when the value of the “operation status” property (0x80) is OFF (0x31).

(25) Measured power consumption of indoor unit

This property indicates the measured power consumption of the indoor unit in 1W increments. The property value range shall be 0x0000 to 0xFFFFD (0 to 65533W). When the property value of the actual piece of equipment is higher than the upper limit of the property value range, 0xFFFF shall be used. When the property value is lower than the lower limit of the property value range, 0xFFFFE shall be used.

(26) Aperture of expansion valve

This property indicates the aperture, in %, of the expansion valve of the indoor unit. The property value range shall be 0x00 to 0x64 (0 to 100%). 0% shall mean that the expansion valve is fully closed and 100% shall mean that the expansion valve is fully open.

This property is used, for example, to control the flow rate of the refrigerant flowing to the individual indoor units.

(27) Temperature setting 2

Used to set the temperature, in 0.1°C increments, for the current operation mode of the package-type commercial air conditioner (indoor unit) that is specified by the “operation mode setting” property, and to acquire the current setting. The air conditioner shall use the value of this property as the target temperature.

This property shall be effective even when the value of the “operation status” property (0x80) is OFF (0x31).

(28) “Relative humidity setting for ‘dehumidification’ mode” 2

Used to set the relative humidity for the “dehumidification” mode (as specified by the “operation mode setting” property (EPC = 0xB0)) in 0.1% increments, and to acquire the current setting. Implementation of this property allows values to be specified and referenced even when a mode other than the “dehumidification” mode is specified by the “operation mode setting” property (EPC = 0xB0).

This property shall be effective even when the value of the “operation status” property (0x80) is OFF (0x31).

(29) “Temperature setting for ‘cooling’ mode” 2

Used to set the temperature for the “cooling” mode (as specified by the “operation mode setting” property (EPC = 0xB0)) in 0.1°C increments, and to acquire the current setting. Implementation of this property allows values to be specified and referenced even when a mode other than the “cooling” mode is specified by the “operation mode setting” property (EPC = 0xB0).

The content of this property must match the content of the “temperature setting” property (EPC = 0xB3).

This property shall be effective even when the value of the “operation status” property (0x80) is OFF (0x31).

(30) “Temperature setting for ‘heating’ mode” 2

Used to set the temperature for the “heating” mode (as specified by the “operation mode setting” property (EPC = 0xB0)) in 0.1°C increments, and to acquire the current setting. Implementation of this property allows values to be specified and referenced even when a mode other than the “heating” mode is specified by the “operation mode setting” property (EPC = 0xB0).

The content of this property must match the content of the “temperature setting” property (EPC = 0xB3).

This property shall be effective even when the value of the “operation status” property (0x80) is OFF (0x31).

(31) “Temperature setting for ‘dehumidification’ mode” 2

Used to set the temperature for the “dehumidification” mode (as specified by the “operation mode setting” property (EPC = 0xB0)) in 0.1°C increments, and to acquire the current setting. Implementation of this property allows values to be specified and referenced even when a mode other than the “dehumidification” mode is specified by the “operation mode setting” property (EPC = 0xB0).

The content of this property must match the content of the “temperature setting” property (EPC = 0xB3).

This property shall be effective even when the value of the “operation status” property (0x80) is OFF (0x31).

(32) Measured indoor relative humidity 2

This property indicates the measured indoor relative humidity in 0.1% increments. The property value range shall be 0x0000 to 0x3E8 (0.0 to 100.0%). When the property value of the actual piece of equipment is higher than the upper limit of the

property value range, the overflow code 0xFFFF shall be used. When the property value is lower than the lower limit of the property value range, the underflow code 0xFFFE shall be used. When the measurement value cannot be returned, 0xFFFD shall be used.

This property shall be effective even when the value of the “operation status” property (0x80) is OFF (0x31).

(33) Measured indoor temperature 2

This property indicates the measured room temperature in 0.1°C increments. The property value range shall be 0xF554 to 0x7FFD (-273.2 to 3276.5°C). When the property value of the actual piece of equipment is higher than the upper limit of the property value range, the overflow code 0x7FFF shall be used. When the property value is lower than the lower limit of the property value range, the underflow code 0x8000 shall be used. When the measurement value cannot be returned, 0x7FFE shall be used.

This property shall be effective even when the value of the “operation status” property (0x80) is OFF (0x31).

(34) “ON timer-based reservation” setting

Used to specify whether or not to use the ON timer (time-based reservation function, relative time-based reservation function or both), and to acquire the current setting. This property is used in combination with the “ON timer setting (time)” or “ON timer setting (relative time)” property.

Both the time- and relative time-based reservation functions are ON = 0x41, both reservation functions are OFF = 0x42, time-based reservation function is ON = 0x43, relative time-based reservation function is ON = 0x44

This property shall be effective even when the value of the “operation status” property (0x80) is OFF (0x31).

(35) ON timer setting (time)

When the ““ON timer-based reservation’ setting” property value is a value for using the time-based reservation function, this property is used to specify the time when the air conditioner will be turned on in “hour (0x00 to 0x17 (0 to 23)) : minute (0x00 to 0x3B (0 to 59))” format, and to acquire the current setting. The higher- and lower-order bytes shall be used for the “hour” and “minute” values, respectively.

This property shall be effective even when the value of the “operation status”

property (0x80) is OFF (0x31).

(36) ON timer setting (relative time)

When the ““ON timer-based reservation’ setting” property value is a value for using the relative time-based reservation function, this property is used to specify the time when the air conditioner will be turned on, in terms of a relative time relative to the current time, and to acquire the current setting. The “hour (0x00 to 0xFF (0 to 255)) : minute (0x00 to 0x3B (0 to 59))” format shall be used, with the higher- and lower-order bytes used for the “hour” and “minute” values, respectively.

This property shall be effective even when the value of the “operation status” property (0x80) is OFF (0x31).

(37) “OFF timer-based reservation” setting

Used to specify whether or not to use the OFF timer (time-based reservation function, relative time-based reservation function or both), and to acquire the current setting. This property is used in combination with the “OFF timer setting (time)” or “OFF timer setting (relative time)” property.

Both the time- and relative time-based reservation functions are ON = 0x41, both reservation functions are OFF = 0x42, time-based reservation function is ON = 0x43, relative time-based reservation function is ON = 0x44

This property shall be effective even when the value of the “operation status” property (0x80) is OFF (0x31).

(38) OFF timer setting (time)

When the ““OFF timer-based reservation’ setting” property value is a value for using the time-based reservation function, this property is used to specify the time when the air conditioner will be turned off in the “hour (0x00 to 0x17 (0 to 23)) : minute (0x00 to 0x3B (0 to 59))” format, and to acquire the current setting. The higher- and lower-order bytes shall be used for the “hour” and “minute” values, respectively.

This property shall be effective even when the value of the “operation status” property (0x80) is OFF (0x31).

(39) OFF timer setting (relative time)

When the ““OFF timer-based reservation’ setting” property value is a value for using the relative time-based reservation function, this property is used to specify

the time when the air conditioner will be turned off, in terms of a relative time relative to the current time, and to acquire the current setting. The “hour (0x00 to 0xFF (0 to 255)) : minute (0x00 to 0x3B (0 to 59))” format shall be used, with the higher- and lower-order bytes used for the “hour” and “minute” values, respectively.

3. 2. 9 Requirements for package-type commercial air conditioner (outdoor unit) class

Class group code : 0x01

Class code : 0x46

Instance code : 0x01 to 0x7F (0x00: All-instance specification code)

Property name	EPC	Contents of property	Data type	Data size	Unit	Access rule	Mandatory	Announcement at status change	Remark
		Value range (decimal notation)							
Operation status	0x80	This property indicates the ON/OFF status.	unsigned char	1 byte	—	Set		○	
		ON=0x30, OFF=0x31				Get	○		
Operation mode setting	0xB0	Used to acquire the current operation mode setting (i.e. “automatic,” “cooling,” “heating,” “dehumidification” or “air circulator”).	unsigned char	1 byte		Set/Get		○	
		The following values shall be used: Automatic: 0x41 Cooling: 0x42 Heating: 0x43 Dehumidification: 0x44 Air circulator: 0x45							
Rated power consumption of outdoor unit	0xB8	Used to acquire the rated power consumption for the cooling, heating and dehumidification modes.	unsigned short × 3	6 bytes	W	Get			
		0x0000–0xFFFD (0–65533W) Cooling: heating: dehumidification							
Measured electric current consumption of outdoor unit	0xB9	Used to acquire the measured electric current consumption.	unsigned short	2 bytes	0.1A	Get			
		0x0000–0xFFFD (0–6553.3A)							
Measured outdoor air temperature 1	0xBE	Used to acquire the measured temperature of the outdoor air.	signed char	1 byte	1°C	Get			
		0x81–0x7D (-127–125°C)							
“Special” state	0xAA	This property indicates when the air conditioner is in the “special” state (i.e. “defrosting” state).	unsigned char	1 byte	-	Get			
		“Normal operation” state = 0x40, “defrosting” state = 0x41							
Operation status of compressor	0xD0	Used to acquire the operation status (i.e. ON or OFF) of the compressor.	unsigned char	1 byte		Get			
		Compressor ON: 0x41 Compressor OFF: 0x42							
Operation mode information	0xD1	Used to acquire the current operation mode (i.e. “cooling,” “heating,” “dehumidification” or “other”).	unsigned char	1 byte		Get	○		
		Cooling: 0x42 Heating: 0x43 Dehumidification: 0x44 Other: 0x40							

Fan rotation speed	0xD2	Used to acquire the rotation speed of the fan of the outdoor unit (expressed in %).	unsigned char	1 byte	%	Get			
		0x00–0x64 (0–100%)							
Measured power consumption of outdoor unit	0xDB	Used to acquire the measured power consumption of the outdoor unit.	unsigned short	2 bytes	W	Get			
		0x0000–0xFFFF (0–65533W)							
Measured outdoor air temperature 2	0xEE	Used to acquire the measured temperature of the outdoor air.	signed short	2 bytes	0.1°C	Get			
		0xF554–0x7FFD (-273,2 –3276,5°C)							

Note: In the “Announcement at status change” column, ○ denotes mandatory processing when the property is implemented.

(1) Operation status (inherited from the device super class property)

This property indicates whether the package-type commercial air conditioner (outdoor unit) is in the ON state (i.e. can respond to user operation) or OFF state. 0x30 and 0x31 shall be used for the ON and OFF states, respectively. In cases where the package-type commercial air conditioner (outdoor unit) belongs to a node in which the “package-type commercial air conditioner (outdoor unit)” class is implemented and is ready to respond to user operation as soon as the node starts up, 0x30 may be implemented as the fixed value.

(2) Operation mode setting

Used to acquire the current operation mode setting of the package-type commercial air conditioner (outdoor unit) (“automatic,” “cooling,” “heating,” “dehumidification” or “air circulator”). 0x41, 0x42, 0x43, 0x44 and 0x45 shall be used for “automatic,” “cooling,” “heating,” “dehumidification” and “air circulator,” respectively. When the value of this property is 0x42 (“cooling”), the outdoor unit can operate in the cooling mode only. In the case of an air conditioner equipped with both an indoor heating unit and an indoor cooling unit, the value for either the indoor heating or indoor cooling unit shall be acquired.

It is only required to implement the property values that correspond to the modes supported by the actual piece of equipment in which this class is implemented. For example, if the piece of equipment in which this class is implemented does not have a heating function, it is not necessary to implement the value for the heating mode (0x43). The current operation mode can be acquired using the “operation mode information” property (Get).

This property shall be effective even when the value of the “operation status” property (0x80) is OFF (0x31).

(3) Rated power consumption of outdoor unit

This property indicates, in watts, the rated power consumption values (brochure values) for the “cooling,” “heating” and “dehumidification” modes. The range of rated power consumption value for each of the 3 modes shall be 0x0000 to 0xFFFFD (0 to 65533W) and the bytes shall be used in such a manner that the three values are indicated in the order stated in the previous sentence. When the actual piece of equipment does not support one or more of the three modes, the underflow code 0xFFFFE shall be used for the unsupported mode(s).

This property shall be effective even when the value of the “operation status” property (0x80) is OFF (0x31).

(4) Measured electric current consumption of outdoor unit

This property indicates the present measured electric current consumption of the outdoor unit in 0.1A increments. When the measured electric current is alternating current, the effective value shall be indicated. The property value range shall be 0x0000 to 0xFFFFD (0 to 6553.3A). When the property value of the actual piece of equipment is higher than the upper limit of the property value range, the overflow code 0xFFFFF shall be used. When the property value is lower than the lower limit of the property value range, the underflow code 0xFFFFE shall be used.

(5) Measured outdoor air temperature 1

This property indicates, in 1°C increments, the measured air temperature (outdoor atmospheric temperature) where the outdoor unit of the package-type commercial air conditioner is installed. The property value range shall be 0x81 to 0x7D (-127 to 125°C). When the property value of the actual piece of equipment is higher than the upper limit of the property value range, the overflow code 0x7F shall be used. When the property value is lower than the lower limit of the property value range, the underflow code 0x80 shall be used. When the measurement value cannot be returned, 0x7E shall be used.

This property shall be effective even when the value of the “operation status” property (0x80) is OFF (0x31).

(6) “Special” state

This property indicates when the package-type commercial air conditioner is in the “special” state, namely, the “defrosting” state.

0x41 shall be used for the “defrosting” state. When the air conditioner is in a state other than the “defrosting” state, 0x40 shall be used.

This property shall be effective even when the value of the “operation status” property (0x80) is OFF (0x31).

(7) Operation status of compressor

This property indicates the operation status (i.e. ON or OFF) of the compressor of the outdoor unit of the package-type commercial air conditioner. 0x41 and 0x42 shall be used for the “compressor ON” and “compressor OFF” states, respectively. In the case where the outdoor unit has two or more compressors, the “compressor OFF” state shall be defined as a state in which all of the compressors are OFF. This property shall be effective even when the value of the “operation status” property (0x80) is OFF (0x31).

(8) Operation mode information

Used to acquire the current operation mode (i.e. “cooling,” “heating,” “dehumidification” or “other”). 0x42, 0x43, 0x44 and 0x40 shall be used for “cooling,” “heating,” “dehumidification” and “other,” respectively. For example, when the value of this property is 0x42 (cooling), it shall mean that the outdoor unit is operating in the “cooling” mode. “Other” shall represent a mode other than the “cooling,” “heating” and “dehumidification” modes, such as an “air circulator” mode. It is only required to implement the property values that correspond to the modes supported by the actual piece of equipment in which this class is implemented.

(9) Fan rotation speed

This property indicates the rotation speed of the fan of the outdoor unit in %. The property value range shall be 0x00 to 0x64 (0 to 100%). When the property value of the actual piece of equipment is higher than the upper limit of the property value range, 0xFF shall be used. When the property value is lower than the lower limit of the property value range, 0xFE shall be used.

(10) Measured power consumption of outdoor unit

This property indicates the measured power consumption of the outdoor unit in 1W increments. The property value range shall be 0x0000 to 0xFFFFD (0 to 65533W). When the property value of the actual piece of equipment is higher than the upper

limit of the property value range, 0xFFFF shall be used. When the property value is lower than the lower limit of the property value range, 0xFFFE shall be used.

(11) Measured outdoor air temperature 2

This property indicates, in 0.1°C increments, the measured air temperature (outdoor atmospheric temperature) where the outdoor unit of the package-type commercial air conditioner is installed.

The property value range shall be 0xF554 to 0x7FFD (-273.2 to 3276.5°C). When the property value of the actual piece of equipment is higher than the upper limit of the property value range, the overflow code 0x7FFF shall be used. When the property value is lower than the lower limit of the property value range, the underflow code 0x8000 shall be used. When the measurement value cannot be returned, 0x7FFE shall be used.

This property shall be effective even when the value of the “operation status” property (0x80) is OFF (0x31).

3. 3 Housing/Facilities-related Device Class Group

This section specifies detailed codes and properties for each ECHONET object belonging to the housing/facilities-related device class group (class group specification code X1 = 0x02). Table 3-3 shows a list of classes specified in detail in this section. In the class requirements, “Mandatory” means that the device mounting each class must mount a combination of its property and service.

Table 3-3 Housing/Facilities-related Device Class Group Object List

Class group code	Class code	Class name	Detailed requirements	Remarks
0x02	0x00 to 0x5F	Reserved for future use		
	0x60	Electrically operated blind/shade	○	
	0x61	Electrically operated shutter	○	
	0x62	Electrically operated curtain		
	0x63	Electrically operated rain sliding door/shutter	○	
	0x64	Electrically operated gate	○	
	0x65	Electrically operated window	○	
	0x66	Automatically operated entrance door/sliding door	○	
	0x67	Garden sprinkler	○	
	0x68	Fire sprinkler		
	0x69	Fountain		
	0x6A	Instantaneous water heater		
	0x6B	Electric water heater	○	
	0x6C	Solar water heater		
	0x6D	Circulation pump		
	0x6E	Bidet-equipped toilet (with electrically warmed seat)	○	
	0x6F	Electric lock	○	
	0x70	Gas line valve		
	0x71	Home sauna		
	0x72	Hot water generator	○	
0x73	Bathroom dryer	○		
0x74	Home elevator			
0x75	Electrically operated room divider			
0x76	Horizontal transfer			
0x77	Electrically operated clothes-drying pole			
0x78	Septic tank			

	0x79	Home solar power generation	○	
	0x7A	Cold/hot water heat source equipment	○	
	0x7B	Floor heater	○	
	0x7C	Fuel cell	○	
	0x7D	Storage battery	○	
	0x7E	Electric vehicle charger/discharger	○	
	0x7F	Engine cogeneration	○	
	0x80	Electric energy meter	○	
	0x81	Water flow meter	○	
	0x82	Gas meter	○	
	0x83	LP gas meter	○	
	0x84	Clock		
	0x85	Automatic door		
	0x86	Commercial elevator		
	0x87	Distribution panel metering	○	
	0x88	Smart electric energy meter	○	
	0x89	Smart gas meter	○	
	0x8A to 0x8F	Reserved for future use		
	0x90 (Note 1)	General lighting class	○	Including chandelier, stand, bracket, downlight, spotlight, pendant light, ceiling light, wall light, etc.
	0x91 to 0x98	Reserved for future use		
	0x99 (Note 2)	Emergency lighting		Including exit light, emergency light, security light, anticrime light, etc.
	0x9A to 0x9C	Reserved for future use		
	0x9D	Equipment light		
	0xA0	Buzzer	○	
	0x9E to 0x9F 0xA1 to 0xFF	Reserved for future use		

Note: ○ indicates that details are explained including the property structure in the APPENDIX.

Note 1: Before Version 2.10, chandeliers, desk/floor stands, brackets, downlight, spotlights, pendant lights, ceiling lights and wall lights were allocated their own class codes. After Version 2.11, these codes were unified into general lighting

fixtures.

Note 2: Before Version 2.10, exit lights, emergency lights, security lights and safety lights were allocated their own class codes. After Version 2.11, these codes were unified into emergency lighting fixtures.

3. 3. 1 Requirements for electrically operated blind/shade class

Class group code : 0x02

Class code : 0x60

Instance code : 0x01–0x7F (0x00: All-instance specification code)

Property name	EPC	Contents of property	Data type	Data size	Unit	Access rule	Mandatory	Announcement at status change	Remark
		Value range (decimal notation)							
Operation status	0x80	This property indicates the ON/OFF status.	unsigned char	1 byte	—	Set		○	
		ON = 0x30, OFF = 0x31				Get			
Fault description (Recoverable faults)	0x89	Fault description	unsigned short	2 bytes	–	Get		○	
		Lower order one byte Restarting the device by performing a reset operation = 0x02 Higher-order one byte Obstacle caught = 0x04 Recovery from outage = 0x05 Time out = 0x06 Battery low = 0x07 0x45 to 0xFF: Defined by user							
Timer operation setting	0x90	Used to specify the timer operation ON or OFF.	unsigned char	1 byte	–	Set/Get		○	
		ON = 0x41, OFF = 0x42							
Wind detection status	0xC2	This property indicates whether wind is detected.	unsigned char	1 byte	–	Get		○	
		Wind = 0x41, No wind = 0x42							
Sunlight detection status	0xC3	This property indicates whether sunlight is detected.	unsigned char	1 byte	–	Get		○	
		Sunlight = 0x41, No sunlight = 0x42							
Opening (extension) speed setting	0xD0	This property specifies the normal opening (extension) speed by levels.	unsigned char	1 byte	–	Set/Get			
		Low = 0x41, Medium = 0x42, High = 0x43							
Closing (retraction) speed setting	0xD1	This property specifies the normal closing (retraction) speed by three levels.	unsigned char	1 byte	–	Set/Get			
		Low = 0x41, Medium = 0x42, High = 0x43							
Operation time	0xD2	This property specifies the operation time in seconds.	unsigned char	1 byte	second	Set/Get			
		0x00–0xFD (0–253 seconds)							
Automatic operation setting	0xD4	Automatic operation ON or OFF.	unsigned char	1 byte	–	Set/Get		○	
		ON = 0x41, OFF = 0x42							
Open/close (extension/retraction) setting	0xE0	Open/close/stop	unsigned char	1 byte	–	Set/Get	○	○	
		Open = 0x41, close = 0x42, stop = 0x43							

Degree-of-opening level	0xE1	Used to specify the Degree-of-opening level in %, and to acquire the current setting. 0x00-0x64 (0-100%)	unsigned char	1 byte	-	Set/Get	ⓔ ⓗ		
Shade angle setting	0xE2	Shade angle value 0x00-0xB4 (0-180°)	unsigned char	1 byte	degree	Set/Get			
Open/close (extension/retraction) speed	0xE3	Low/Medium/High Low = 0x41, Medium = 0x42, High = 0x43	unsigned char	1 byte	-	Set/Get			
Electric lock setting	0xE5	Lock or unlock of an electric lock Lock = 0x41, Unlock = 0x42	unsigned char	1 byte	-	Set/Get			
Remote operation setting status	0xE8	This property indicates whether remote operation is permitted or prohibited. ON (permitted) = 0x41, OFF (prohibited) = 0x42	unsigned char	1 byte	-	Get		○	
Selective opening (extension) operation setting	0xE9	Sets a stop at a specified value. Degree-of-setting position: Open = 0x41 Operation time setting value: Open = 0x42 Operation time setting value: Close = 0x43 Local setting position = 0x44 Hereinafter, defined by user (Shortcut to degree-of-opening setting, etc.)	unsigned char	1 byte	-	Set/Get		○	
Open/closed (extended/retracted) status	0xEA	This property indicates the open/closed status. Fully open = 0x41, Fully closed = 0x42, Open = 0x43, Closed = 0x44, Stopped halfway = 0x45	unsigned char	1 byte	-	Get		○	
One-time opening (extension) speed setting	0xEE	Used to specify the speed of single opening operation by three levels. Low = 0x41, Medium = 0x42, High = 0x43, None = 0x44	unsigned char	1 byte	-	Set/Get			
One-time closing (retraction) speed setting	0xEF	Used to specify the speed of single closing operation by three levels. Low = 0x41, Medium = 0x42, High = 0x43, None = 0x44	unsigned char	1 byte	-	Set/Get			

Note: In the “Announcement at status change” column, ○ denotes mandatory processing when the property is implemented.

(1) Operation status (inherited from the device object super class property)

This property indicates whether an electrically operated blind/shade is ready to accept control commands (ON) or not (OFF). The property value is 0x30 for ON and 0x31 for OFF. If an electrically operated blind/shade ready to accept control commands at the start of a node where the electrically operated blind/shade class is installed, the value can be fixed at 0x30 at installation.

(2) Fault description (inherited from the device object super class property)

The description here is limited to what are not defined in the super class. This property acquires the description of recoverable faults about an electrically operated blind/shade up to the detailed fault classification. The general fault classification shall be fixed at the lower-order byte, and 0x02 indicates a fault that can be recovered from by restarting the device by performing a reset operation in the super class classification. The detailed fault classification shall be fixed at the higher-order byte.

Obstacle caught = 0x04, Recovery from outage = 0x05, Time out = 0x06, Battery low = 0x07, 0x45 to 0xFF are defined by the user

(3) Timer operation setting

The property value is 0x41 (ON) to enable timer operation that starts opening or closing at a time preset to the device or 0x42 (OFF) to disable timer operation. Then the contents of setting are acquired.

(4) Wind detection status

This property indicates whether the wind speed has reached the level preset in the device. The value is 0x41 (Wind) when the level has been reached and 0x42 (No wind) when not.

(5) Sunlight detection status

This property indicates whether the illuminance has reached the level preset in the device. The value is 0x41 (Sunlight) when the level has been reached and 0x42 (No sunlight) when not.

(6) Opening (extension) speed setting

This property specifies the speed in the opening (extension) direction as a repeatedly available value and indicates the speed by three levels (Low/Medium/High).

(7) Closing (retraction) speed setting

This property specifies the speed in the closing (retraction) direction as a repeatedly available value and indicates the speed by three levels (Low/Medium/High).

(8) Operation time

When operation is set by the opening/closing (extension/retraction) operation setting property (0xE0), this property sets the operation time of an electrically operated blind/shade in seconds and acquires the contents of the setting. The operation time

is 0 to 253 seconds (0x00 to 0xFD).

(9) Automatic operation setting

The property value is set to 0x41 (ON) to enable the automatic operation of a device supporting automatic operation or 0x42 (OFF) to disable it. Then the contents of setting are acquired.

(10) Open/close (extension/retraction) operation setting

This property sets the open/close (extension/retraction) or stop operation of an electrically operated blind/shade and acquires the contents of the setting. The property value is 0x41 for open (extension), 0x42 for close (retraction), and 0x43 for stop. The target of operation setting by this property is the fully open position after open (extension) and the fully closed position after close (retraction). For a stop at any other position, stop operation shall be set (0x43) during operation or the selective opening (extension) operation setting property (0xE9) shall be used.

(11) Degree-of-opening

This property sets the degree-of-opening of an electrically operated blind/shade within the range from 0 to 100% and acquires the operation setting when the value of the selective opening (extension) operation setting property (0xE9) is 0x41 (open). The value 0x00 (degree-of-opening: 0%) shall represent the state nearest to the fully closed state (i.e., not fully closed) and the value 0x64 (degree-of-opening: 100%) shall represent the fully open state. During the process of the blind/shade reaching the target position, the target degree-of-opening setting position shall be returned. In the case where an “energy service” or a “home amenity service” is to be supported, the implementation of this property is mandatory.

(12) Shade angle setting

This property indicates the blind angle of an electrically operated blind from the indoor side in degrees.

In the case of a horizontal electric blind, the blind slats shall be regarded as being in the 90° and 0° positions when blind slats are horizontal and at the highest position inside the room (the light blocking side (convex face outward) is vertical), respectively.

In the case of a vertical electric blind, the blind slats shall be regarded as being in the 0° and 180° positions when the outdoor side surfaces of the blind slats are in the rightmost and leftmost positions as seen from the inside, respectively. The blind slats shall be regarded as being in the 90° position when they are at the midpoint between the 0° and 180° positions.

- (13) Open/close (extension/retraction) speed setting
This property indicates the open/close (extension/retraction) speed by three levels (Low/Medium/High).
- (14) Electric lock setting
This property locks or unlocks an electrically operated blind/shade and acquires the lock status. The property value is 0x41 for the locked status and 0x42 for the unlocked status.
- (15) Remote operation setting status
This property acquires whether an electrically operated blind/shade permits or prohibits remote operation from outside. The value is 0x41 (ON) when remote operation from outside is permitted and 0x42 (OFF) when it is prohibited. The value can be fixed at 0x41 (ON) at installation to use an electrically operated blind/shade not independently but always by remote operation.
- (16) Selective opening (extension) operation setting
This property indicates the setting to operate or stop an electrically operated blind/shade as specified by another property or device. The property value is 0x41 for operation by “Degree-of-opening level” (0xE1), 0x42 for operation in the opening (extension) direction by “Operation time” (0xD2), 0x43 for operation in the closing (retraction) direction by “Operation time setting value” (0xD2), and 0x44 for stop at a position stored independently by the electrically operated blind/shade. User definition shall be permitted for a stop by opening (extension) level setting using a single signal.
- (17) Open/closed (extended/retracted) status
This property acquires the open/closed (extended/retracted) status of an electrically operated blind/shade. In the fully open (extended) status, the blind/shade is stopped at the upper limit and the property value is 0x41. In the fully closed (retracted) status, the blind/shade is stopped at the lower limit and the property value is 0x42. In the opening (extension) operation status, the blind/shade is being operated in the opening (extension) direction and the property value is 0x43. In the closing (retraction) operation status, the blind/shade is being operated in the closing (retraction) direction and the property value is 0x44. When the blind/shade is stopped not at the upper or lower limit but halfway, the property value is 0x45.
- (18) One-time opening (extension) speed setting
This property specifies the speed in the opening (extension) direction once only by

three levels (Low/Medium/High) and acquires the contents of the setting. The value is 0x41 for low speed, 0x42 for medium speed, 0x43 for high speed, and 0x44 for no setting. After single operation at the speed set by this property, the value changes to 0x44. When the value of this property is 0x44, the operation speed is as set by the opening speed setting property.

(19) One-time closing (retraction) speed setting

This property specifies the speed in the closing (retraction) direction once only by three levels (Low/Medium/High) and acquires the contents of the setting. The value is 0x41 for low speed, 0x42 for medium speed, 0x43 for high speed, and 0x44 for no setting. After single operation at the speed set by this property, the value changes to 0x44. When the value of this property is 0x44, the operation speed is as set by the closing speed setting property.

3. 3. 2 Requirements for electrically operated shutter class

Class group code : 0x02

Class code : 0x61

Instance code : 0x01–0x7F (0x00: All-instance specification code)

Property name	EPC	Contents of property	Data type	Data size	Unit	Access rule	Mandatory	Announcement at status change	Remark
		Value range (decimal notation)							
Operation status	0x80	This property indicates the ON/OFF status.	unsigned char	1 byte	—	Set		○	
		ON = 0x30, OFF = 0x31				Get			
Fault description (Recoverable faults)	0x89	Fault description	unsigned short	2 bytes	—	Get		○	
		Lower order one byte Restarting the device by performing a reset operation = 0x02 Higher-order one byte Obstacle caught = 0x04 Recovery from outage = 0x05 Time out = 0x06 Battery low = 0x07 0x45 to 0xFF: Defined by user							
Timer operation setting	0x90	Timer operation ON/OFF	unsigned char	1 byte	—	Set/Get		○	
		ON = 0x41, OFF = 0x42							
Opening speed setting	0xD0	Used to specify the normal opening speed by three levels.	unsigned char	1 byte	—	Set/Get			
		Low = 0x41, Medium = 0x42, High = 0x43							
Closing speed setting	0xD1	Used to specify the normal closing speed by three levels.	unsigned char	1 byte	—	Set/Get			
		Low = 0x41, Medium = 0x42, High = 0x43							
Operation time	0xD2	Used to specify the operation time in seconds.	unsigned char	1 byte	second	Set/Get			
		0x00 to 0xFD (0 to 253 s)							
Open/close operation setting	0xE0	Open/Close/Stop	unsigned char	1 byte	—	Set/Get	○	○	
		Open = 0x41, Close = 0x42, Stop = 0x43							
Degree-of-opening setting	0xE1	Used to specify the degree-of-opening in %.	unsigned char	1 byte	—	Set/Get			
		0x00–0x64 (0–100%)							
Blind angle setting	0xE2	Blind angle	unsigned char	1 byte	degree	Set/Get			
		0x00–0xB4 (0–180°)							
Open/close speed setting	0xE3	Low/Medium/High	unsigned char	1 byte	—	Set/Get			
		Low = 0x41, Medium = 0x42, High = 0x43							
Electric lock setting	0xE5	Locks or unlocks an electric lock	unsigned char	1 byte	—	Set/Get			
		Lock = 0x41, Unlock = 0x42							

Remote operation setting status	0xE8	Indicates whether remote operation is permitted or prohibited.	unsigned char	1 byte	—	Get		○	
		ON (permitted) = 0x41 OFF (prohibited) = 0x42							
Selective degree-of-opening setting	0xE9	Sets a stop at a specified value.	unsigned char	1 byte	—	Set/Get		○	
		Degree-of-opening setting position: Open = 0x41 Operation time setting value: Open = 0x42 Operation time setting value: Close = 0x43 Local setting position = 0x44 Slit degree-of-opening setting = 0x45 Hereinafter, defined by user (Shortcut to degree-of-opening setting, etc.)							
Open/closed status	0xEA	Indicates the open/closed status.	unsigned char	1 byte	—	Get		○	
		Fully open = 0x41, Fully closed = 0x42, Opening = 0x43, Closing = 0x44, Stopped halfway = 0x45							
Slit degree-of-opening setting	0xED	Used to specify the degree-of-opening by 8 levels.	unsigned char	1 byte	—	Set/Get			
		0x31–0x38							
One-time opening speed setting	0xEE	Used to specify the speed of single opening operation by three levels.	unsigned char	1 byte	—	Set/Get			
		Low = 0x41, Medium = 0x42, High = 0x43, None = 0x44							
One-time closing speed setting	0xEF	Used to specify the speed of single closing operation by three levels.	unsigned char	1 byte	—	Set/Get			
		Low = 0x41, Medium = 0x42, High = 0x43, None = 0x44							

Note: In the “Announcement at status change” column, ○ denotes mandatory processing when the property is implemented.

It is recommended that the electrically operated shutter class is used when the shutter is mounted alone, and the electrically operated rain sliding door/shutter class is used when the shutter is mounted with windows, sliding doors, etc.

(1) Operation status (inherited from the device object super class property)

This property indicates whether the electrically operated shutter is in the ON state (i.e. the electric shutter responds to user operation) or OFF state. The property value is 0x30 for ON and 0x31 for OFF. If an electrically operated shutter ready to accept control commands at the start of a node where the electrically operated shutter class is installed, the value can be fixed at 0x30 at installation.

(2) Fault description (inherited from the device object super class property)

The description here is limited to what are not defined in the super class. This

property acquires the description of recoverable faults about an electrically operated shutter up to the detailed fault classification. The general fault classification shall be fixed at the lower-order byte, and 0x02 indicates a fault that can be recovered from by restarting the device by performing a reset operation in the super class classification. The detailed fault classification shall be fixed at the higher-order byte. Obstacle caught = 0x04, Recovery from outage = 0x05, Time out = 0x06, Battery low = 0x07, 0x45 to 0xFF are defined by the user

(3) Timer operation setting

The property value is 0x41 (ON) to enable timer operation that starts opening or closing at a time preset to the device or 0x42 (OFF) to disable timer operation. Then the contents of setting are acquired.

(4) Opening speed setting

This property specifies the speed in the opening direction as a repeatedly available value and indicates the speed by three levels (Low/Medium/High).

(5) Closing speed setting

This property specifies the speed in the closing direction as a repeatedly available value and indicates the speed by three levels (Low/Medium/High).

(6) Operation time setting value

When operation is set by the open/close operation setting property (0xE0), this property sets the operation time of an electrically operated shutter in seconds and acquires the contents of the setting. The operation time is 0 to 253 seconds (0x00 to 0xFD).

(7) Open/close operation setting

Used to specify whether to open, close or stop the electrically operated shutter, and to acquire the current setting. 0x41, 0x42 and 0x43 shall be used for the “open,” “close” and “stop” options, respectively. For the purposes of this property, “open” or “close” shall mean fully opening or closing the shutter, respectively. For a stop at any other position, stop operation shall be set (0x43) during operation or the selective degree-of-opening setting property (0xE9) shall be used.

(8) Degree-of-opening level setting

Used, when the value of the selective degree-of-opening setting property (0xE9) indicates 0x41 (open), to specify the extent of opening of the electrically operated shutter by selecting a level within the range from 0 to 100%, and to acquire the

current setting. The value 0x00 (degree-of-opening: 0%) shall represent the state nearest to the fully closed state (i.e., not fully closed) and the value 0x64 (degree-of-opening: 100%) shall represent the fully open state. When the shutter reaches the target position, the target of degree-of-opening level shall be returned.

(9) Blind angle setting

This property indicates the blind angle (in degrees) of the electrically operated shutter.

In the case of a horizontal blind, the blind slats shall be regarded as being in the 90° and 0° positions when the blind slats are horizontal and when the indoor side surfaces of the blind slats are in the highest position (the light blocking side (convex face outward) is vertical), respectively.

In the case of a vertical blind, the blind slats shall be regarded as being in the 0° and 180° positions when the outdoor side surfaces of the blind slats are in the rightmost and leftmost positions, respectively, as seen from the inside. The blind slats shall be regarded as being in the 90° position when they are at the midpoint between the 0° and 180° positions.

(10) Open/close speed setting

This property indicates the opening and closing speed of the electrically operated shutter at 3 levels: low, medium or high.

(11) Electric lock setting

This property locks or unlocks an electrically operated shutter and acquires the lock status. The property value is 0x41 for the locked status and 0x42 for the unlocked status.

(12) Remote operation setting status

This property acquires whether an electrical shutter permits or prohibits remote operation from outside. The value is 0x41 (ON) when remote operation from outside is permitted and 0x42 (OFF) when it is prohibited. The value can be fixed at 0x41 (ON) at installation to use an electrically operated shutter not independently but always by remote operation.

(13) Selective degree-of-opening setting

This property indicates the setting to operate or stop an electrically operated shutter as specified by another property or device. The property value is 0x41 for operation by “Degree-of-opening setting” (0xE1), 0x42 for operation in the opening direction by “Operation time setting value” (0xD2), 0x43 for operation in the closing direction by “Operation time setting value” (0xD2), 0x44 for stop at a position stored

independently by the electrically operated shutter, and 0x45 for slit operation by the slit degree-of-opening setting property (0xED). User definition shall be permitted for a stop by opening level setting using a single signal.

(14) Open/closed status

This property acquires the open/closed status of an electrically operated shutter. In the fully open status, the shutter is stopped at the upper limit and the property value is 0x41. In the fully closed status, the shutter is stopped at the lower limit and the property value is 0x42. When the shutter has a slit, the slit should also be closed. In the opening operation status, the shutter is being operated in the opening direction and the property value is 0x43. In the closing operation status, the shutter is being operated in the closing direction and the property value is 0x44. When the shutter is stopped not at the upper or lower limit but halfway, the property value is 0x45.

(15) Slit degree-of-opening setting

This property indicates the degree of slit opening of a shutter with a slit by 8 levels and acquires the contents of the setting. The status on each level is not defined specifically. However, the property value is 0x31 for the most open status and 0x38 for the most closed status (not fully closed).

(16) One-time opening speed setting

This property specifies the speed in the opening direction once only by three levels (Low/Medium/High) and acquires the contents of the setting. The value is 0x41 for low speed, 0x42 for medium speed, 0x43 for high speed, and 0x44 for no setting. After single operation at the speed set by this property, the value changes to 0x44. When the value of this property is 0x44, the operation speed is as set by the opening speed setting property.

(17) One-time closing speed setting

This property specifies the speed in the closing direction once only by three levels (Low/Medium/High) and acquires the contents of the setting. The value is 0x41 for low speed, 0x42 for medium speed, 0x43 for high speed, and 0x44 for no setting. After single operation at the speed set by this property, the value changes to 0x44. When the value of this property is 0x44, the operation speed is as set by the closing speed setting property.

3. 3. 3 Requirements for electrically operated rain sliding door/shutter class

Class group code : 0x02

Class code : 0x63

Instance code : 0x01 to 0x7F (0x00: All-instance specification code)

Property name	EPC	Contents of property	Data type	Data size	Unit	Access rule	Mandatory	Announcement at status change	Remark
		Value range (decimal notation)							
Operation status	0x80	This property indicates the ON/OFF status.	unsigned char	1 byte	—	Set	○	○	
		ON = 0x30, OFF = 0x31				Get			
Fault description (Recoverable faults)	0x89	Fault description	unsigned short	2 bytes	—	Get	○	○	
		Lower order one byte Restarting the device by performing a reset operation = 0x02 Higher-order one byte Obstacle caught = 0x04 Recovery from outage = 0x05 Time out = 0x06 Battery low = 0x07 0x45 to 0xFF: Defined by user							
Timer operation setting	0x90	Turns the timer operation ON or OFF.	unsigned char	1 byte	—	Set/Get	○	○	
		ON = 0x41, OFF = 0x42							
Opening speed setting	0xD0	Used to specify the normal opening speed by three levels.	unsigned char	1 byte	—	Set/Get			
		Low = 0x41, Medium = 0x42, High = 0x43							
Closing speed setting	0xD1	Used to specify the normal closing speed by three levels.	unsigned char	1 byte	—	Set/Get			
		Low = 0x41, Medium = 0x42, High = 0x43							
Operation time	0xD2	Used to specify the operation time in seconds.	unsigned char	1 byte	second	Set/Get			
		0x00~0xFD (0–255 seconds)							
Open/close operation setting	0xE0	Open/Close/Stop	unsigned char	1 byte	—	Set/Get	○	○	
		Open = 0x41, Close = 0x42, Stop = 0x43							
Degree-of-opening setting	0xE1	Used to specify the degree-of-opening in %.	unsigned char	1 byte	—	Set/Get			
		0x00–0x64 (0–100%)							
Blind angle	0xE2	Blind angle	unsigned	1	degr	Set/			

setting		0x00-0xB4 (0-180°)	char	byte	ee	Get			
Opening/closing speed setting	0xE3	Low/Medium/High	unsigned char	1 byte	—	Set/Get			
		Low = 0x41, Medium = 0x42, High = 0x43							
Electric lock setting	0xE5	Locks or unlocks an electric lock.	unsigned char	1 byte	—	Set/Get			
		Lock = 0x41, Unlock = 0x42							
Remote operation setting status	0xE8	Indicates whether remote operation is permitted or prohibited.	unsigned char	1 byte	—	Get		○	
		ON (permitted) = 0x41 OFF (prohibited) = 0x42							
Selective degree-of-opening setting	0xE9	Sets a stop at a specified value.	unsigned char	1 byte	—	Set/Get		○	
		Degree-of-opening setting position: Open = 0x41 Operation time setting value: Open = 0x42 Operation time setting value: Close = 0x43 Local setting position = 0x44 Slit degree-of-opening setting = 0x45 Hereinafter, defined by user (Shortcut to degree-of-opening setting, etc.)							
Open/closed status	0xEA	Indicates the open/closed status.	unsigned char	1 byte	—	Get		○	
		Fully open = 0x41, Fully closed = 0x42, Opening = 0x43, Closing = 0x44, Stopped halfway = 0x45							
Slit degree-of-opening	0xED	Used to specify the degree-of-opening by 8 levels.	unsigned char	1 byte	—	Set/Get			
		0x31 to 0x38							
One-time opening speed setting	0xEE	Used to specify the speed of single opening operation by three levels.	unsigned char	1 byte	—	Set/Get			
		Low = 0x41, Medium = 0x42, High = 0x43, None = 0x44	unsigned char						
One-time closing speed setting	0xEF	Used to specify the speed of single closing operation by three levels.	unsigned char	1 byte	—	Set/Get			
		Low = 0x41, Medium = 0x42, High = 0x43, None = 0x44							

Note: In the “Announcement at status change” column, ○ denotes mandatory processing when the property is implemented.

It is recommended that the electrically operated rain sliding door/shutter class is used

when the shutter is mounted with windows, sliding doors, etc. and the electrically operated shutter class is used when the shutter is mounted alone.

(1) Operation status (inherited from the super class property)

This property indicates whether the electrically operated rain sliding door/shutter is in the ON state (i.e. the electrically operated rain sliding door/shutter responds to user operation) or OFF state. The property value is 0x30 for ON and 0x31 for OFF. If an electrically operated rain sliding door/shutter ready to accept control commands at the start of a node where the electrically operated rain sliding door/shutter class is installed, the value can be fixed at 0x30 at installation.

(2) Fault description (inherited from the device object super class property)

The description here is limited to what are not defined in the super class. This property acquires the description of recoverable faults about an electrically operated rain sliding door/shutter up to the detailed fault classification. The general fault classification shall be fixed at the lower-order byte, and 0x02 indicates a fault that can be recovered from by restarting the device by performing a reset operation in the super class classification. The detailed fault classification shall be fixed at the higher-order byte.

Obstacle caught = 0x04, Recovery from outage = 0x05, Time out = 0x06, Battery low = 0x07, 0x45 to 0xFF are defined by the user

(3) Timer operation setting

The property value is 0x41 (ON) to enable timer operation that starts opening or closing at a time preset to the device or 0x42 (OFF) to disable timer operation. Then the contents of setting are acquired.

(4) Opening speed setting

This property specifies the speed in the opening direction as a repeatedly available value and indicates the speed by three levels (Low/Medium/High).

(5) Closing speed setting

This property specifies the speed in the closing direction as a repeatedly available value and indicates the speed by three levels (Low/Medium/High).

(6) Operation time setting value

When operation is set by the open/close operation setting property (0xE0), this property sets the operation time of an electrically operated rain sliding door/shutter in seconds and acquires the contents of the setting. The operation time is 0 to 253

seconds (0x00 to 0xFD).

(7) Open/close operation setting

This property sets the opening/closing or stop operation of an electrically operated rain sliding door/shutter and acquires the contents of the setting. The property value is 0x41 for opening, 0x42 for closing, and 0x43 for stop. The target of operation setting by this property is the fully open position after opening and the fully closed position after closing. For a stop at any other position, stop operation shall be set (0x43) during operation or the selective degree-of-opening setting property (0xE9) shall be used.

(8) Degree-of-opening setting

When “Degree-of-opening setting position: Open” (0x41) is set by the selective degree-of-opening property (0xE9), this property sets the degree-of-opening of an electrically operated rain sliding door/shutter within the range from 0 to 100% and acquires the operation result. The property value is 0x00 (Degree-of-opening: 0%) for a status closest to the closed status (not fully closed) and 0x64 (Degree-of-opening: 100%) for a status of the greatest opening (fully open). During the process of reaching the target position, the target of degree-of-opening setting position shall be returned.

(9) Blind angle setting value

This property indicates the blind angle of an electrically operated rain sliding door/shutter from the indoor side in degrees.

In the case of a horizontal blind, the slats are horizontal at 90 degrees and at the highest position inside the room (the light blocking side (convex face outward) is vertical) at 0 degree.

In the case of a vertical blind, the slats outside the room are at the rightmost position at 0 degree when viewed from inside the room, at the leftmost position at 180 degrees, and in the middle between them at 90 degrees.

(10) Opening/closing speed setting

This property indicates the opening/closing speed of an automatically operated rain sliding door/shutter by three levels (Low/Medium/High).

(11) Electric lock setting

This property locks or unlocks an electrically operated rain sliding door/shutter and acquires the lock status. The property value is 0x41 for the locked status and 0x42 for the unlocked status.

(12) Remote operation setting status

This property acquires whether an electrically operated rain sliding door/shutter permits or prohibits remote operation from outside. The value is 0x41 (ON) when remote operation from outside is permitted and 0x42 (OFF) when it is prohibited. The value can be fixed at 0x41 (ON) at installation to use an electrically operated rain sliding door/shutter not independently but always by remote operation.

(13) Selective degree-of-opening setting

This property indicates the setting to operate or stop an electrically operated rain sliding door/shutter as specified by another property or device. The property value is 0x41 for operation by “Degree-of-opening setting” (0xE1), 0x42 for operation in the opening direction by “Operation time setting value” (0xD2), 0x43 for operation in the closing (retraction) direction by “Operation time setting value” (0xD2), 0x44 for stop at a position stored independently by the electrically operated rain sliding door/shutter, and 0x45 for slit operation by the slit degree-of-opening setting property (0xED). User definition shall be permitted for a stop by opening level setting using a single signal.

(14) Open/closed status

This property acquires the open/closed status of an electrically operated rain sliding door/shutter. In the fully open status, the rain sliding door/shutter is stopped at the upper limit and the property value is 0x41. In the fully closed status, the rain sliding door/shutter is stopped at the lower limit and the property value is 0x42. When the rain sliding door/shutter has a slit, the slit should also be closed. In the opening operation status, the rain sliding door/shutter is being operated in the opening direction and the property value is 0x43. In the closing operation status, the rain sliding door/shutter is being operated in the closing direction and the property value is 0x44. When the rain sliding door/shutter is stopped not at the upper or lower limit but halfway, the property value is 0x45.

(15) Slit degree-of-opening setting

This property indicates the degree of slit opening of a rain sliding door/shutter with a slit by 8 levels and acquires the contents of the setting. The status on each level is not defined specifically. However, the property value is 0x31 for the most open status and 0x38 for the most closed status (not fully closed).

(16) One-time opening speed setting

This property specifies the speed in the opening direction once only by three levels (Low/Medium/High) and acquires the contents of the setting. The value is 0x41 for low speed, 0x42 for medium speed, 0x43 for high speed, and 0x44 for no setting.

After single operation at the speed set by this property, the value changes to 0x44.
When the value of this property is 0x44, the operation speed is as set by the opening speed setting property.

(17) One-time closing speed setting

This property specifies the speed in the closing direction once only and by three levels (Low/Medium/High) and acquires the contents of the setting. The value is 0x41 for low speed, 0x42 for medium speed, 0x43 for high speed, and 0x44 for no setting. After single operation at the speed set by this property, the value changes to 0x44. When the value of this property is 0x44, the operation speed is as set by the closing speed setting property.

3. 3. 4 Requirements for electrically operated gate class

Class group code : 0x02

Class code : 0x64

Instance code : 0x01 to 0x7F (0x00: All-instance specification code)

Property name	EPC	Contents of property	Data type	Data size	Unit	Access rule	Mandatory	Announcement at status change	Remark
		Value range (decimal notation)							
Operation status	0x80	This property indicates the ON/OFF status.	unsigned char	1 byte	—	Set		○	
		ON = 0x30, OFF = 0x31				Get	○		
Fault description (Recoverable faults)	0x89	Fault description	unsigned short	2 bytes		Get		○	
		Lower order one byte Restarting the device by performing a reset operation = 0x02 Higher-order one byte Obstacle caught = 0x04 Recovery from outage = 0x05 Time out = 0x06 Battery low = 0x07 0x45 to 0xFF: Defined by user							
Opening speed setting	0xD0	Used to specify the normal opening speed by three levels.	unsigned char	1 byte		Set/Get			
		Low = 0x41, Medium = 0x42, High = 0x43							
Closing speed setting	0xD1	Used to specify the normal closing speed by three levels.	unsigned char	1 byte		Set/Get			
		Low = 0x41, Medium = 0x42, High = 0x43							
Operation time setting value	0xD2	Used to specify the operation time in seconds.	unsigned char	1 byte		Set/Get			
		0x00 to 0xFD (0 to 253 seconds)							
Opening/closing operation setting	0xE0	Open/Close/Stop	unsigned char	1 byte		Set/Get	○	○	
		Open = 0x41, Close = 0x42, Stop = 0x43							
Degree-of-opening setting	0xE1	Used to specify the degree-of-opening in %.	unsigned char	1 byte		Set/Get			
		0x00 to 0x64 (0 to 100%)							
Opening/closing speed setting	0xE3	Low/Medium/High	unsigned char	1 byte	—	Set/Get			
		Low = 0x41, Medium = 0x42, High = 0x43							
Electric lock setting	0xE5	Locks or unlocks an electric lock.	unsigned char	1 byte	—	Set/Get			
		Lock = 0x41, Unlock = 0x42							
Remote operation	0xE8	Indicates whether remote operation is permitted or prohibited.	unsigned	1	—	Get		○	

setting status		ON (permitted) = 0x41, OFF (prohibited) = 0x42	char	byte					
Selective degree-of-opening setting	0xE9	Sets a stop at a specified value.	unsigned char	1 byte	—	Set/Get		○	
		Degree-of-opening setting position: Open = 0x41 Operation time setting value: Open = 0x42 Operation time setting value: Close = 0x43 Local setting position = 0x44 Hereinafter, defined by user (Shortcut to degree-of-opening setting, etc.)							
Open/closed status	0xEA	Indicates the open/closed status.	unsigned char	2 bytes	—	Get		○	
		Fully open = 0x41, Fully closed = 0x42, Opening = 0x43, Closing = 0x44, Stopped halfway = 0x45							
One-time opening speed setting	0xEE	Used to specify the speed of single opening operation by three levels.	unsigned char	1 byte	—	Set/Get			
		Low = 0x41, Medium = 0x42, High = 0x43, None = 0x44							
One-time closing speed setting	0xEF	Used to specify the speed of single closing operation by three levels.	unsigned char	1 byte		Set/Get			
		Low = 0x41, Medium = 0x42, High = 0x43, None = 0x44							

Note: In the “Announcement at status change” column, ○ denotes mandatory processing when the property is implemented.

(1) Operation status (inherited from the super class property)

This property indicates whether an electrically operated gate is ready to accept control commands (ON) or not (OFF). The property value is 0x30 for ON and 0x31 for OFF. If an electrically operated gate becomes ready to accept control commands at the start of a node where the electrically operated gate class is installed, the value can be fixed at 0x30 at installation.

(2) Fault description (inherited from the super class property)

The description here is limited to what are not defined in the super class. This property acquires the description of recoverable faults about an electrically operated gate up to the detailed fault classification. The general fault classification shall be fixed at the lower-order byte, and 0x02 indicates a fault that can be recovered from by restarting the device by performing a reset operation in the super class classification. The detailed fault classification shall be fixed at the higher-order byte.

Obstacle caught = 0x04, Recovery from outage = 0x05, Time out = 0x06, Battery low = 0x07, 0x45 to 0xFF are defined by the user

(3) Opening speed setting

This property specifies the speed in the opening direction as a repeatedly available value and indicates the speed by three levels (Low/Medium/High).

(4) Closing speed setting

This property specifies the speed in the closing direction as a repeatedly available value and indicates the speed by three levels (Low/Medium/High).

(5) Operation time setting value

When operation is set by the opening/closing operation setting property (0xE0), this property sets the operation time of an electrically operated gate in seconds and acquires the contents of the setting. The operation time is 0 to 253 seconds (0x00 to 0xFD).

(6) Opening/closing operation setting

This property sets the opening/closing or stop operation of an electrically operated gate and acquires the contents of the setting. The property value is 0x41 for opening, 0x42 for closing, and 0x43 for stop. The target of operation setting by this property is the fully open position after opening and the fully closed position after closing. For a stop at any other position, stop operation shall be set (0x43) during operation or the selective opening operation setting property (0xE9) shall be used.

(7) Degree-of-opening setting

When “Degree-of-opening setting position: Open” (0x41) is set by the selective degree-of-opening property (0xE9), this property sets the degree-of-opening of an electrically operated gate within the range from 0 to 100% and acquires the operation result. The property value is 0x00 (Degree-of-opening: 0%) for a status closest to the closed status (not fully closed) and 0x64 (Degree-of-opening: 100%) for a status of the greatest opening (fully open). When the gate reaches the target position, the target degree-of-opening setting position shall be returned.

(8) Opening/closing speed setting

This property indicates the opening/closing speed of an electrically operated gate by three levels (Low/Medium/High).

(9) Electric lock setting

This property locks or unlocks an electrically operated gate and acquires the lock status. The property value is 0x41 for the locked status and 0x42 for the unlocked status.

(10) Remote operation setting status

This property acquires whether an electrically operated gate permits or prohibits remote operation from outside. The value is 0x41 (ON) when remote operation from outside is permitted and 0x42 (OFF) when it is prohibited. The value can be fixed at 0x41 (ON) at installation to use an electrically operated gate not independently but always by remote operation.

(11) Selective degree-of-opening setting

This property indicates the setting to operate or stop an electrically operated gate as specified by another property or device. The property value is 0x41 for operation by “Degree-of-opening setting” (0xE1), 0x42 for operation in the opening direction by “Operation time setting value” (0xD2), 0x43 for operation in the closing direction by “Operation time setting value” (0xD2), and 0x44 for stop at a position stored independently by the electrically operated gate. User definition shall be permitted for a stop by opening level setting using a single signal.

(12) Open/closed status

This property acquires the open/closed status of an electrically operated gate. In the fully open status, the gate is stopped at the upper limit and the property value is 0x41. In the fully closed status, the gate is stopped at the lower limit and the property value is 0x42. In the opening operation status, the gate is being operated in the opening direction and the property value is 0x43. In the closing operation status, the gate is being operated in the closing direction and the property value is 0x44. When the shutter is stopped not at the upper or lower limit but halfway, the property value is 0x45.

(13) One-time opening speed setting

This property specifies the speed in the opening direction once only and by three levels (Low/Medium/High) and acquires the contents of the setting. The value is 0x41 for low speed, 0x42 for medium speed, 0x43 for high speed, and 0x44 for no setting. After single operation at the speed set by this property, the value changes to 0x44. When the value of this property is 0x44, the operation speed is as set by the opening speed setting property.

(14) One-time closing speed setting

This property specifies the speed in the closing direction once only and by three levels (Low/Medium/High) and acquires the contents of the setting. The value is 0x41 for low speed, 0x42 for medium speed, 0x43 for high speed, and 0x44 for no setting. After single operation at the speed set by this property, the value changes to 0x44. When the value of this property is 0x44, the operation speed is as set by the closing speed setting property.

3. 3. 5 Requirements for electrically operated window class

Class group code : 0x02

Class code : 0x65

Instance code : 0x01–0x7F (0x00: All-instance specification code)

Property name	EPC	Contents of property	Data type	Data size	Unit	Access rule	Mandatory	Announcement at status change	Remark
		Value range (decimal notation)							
Operation status	0x80	This property indicates the ON/OFF status.	unsigned char	1 byte	-	Set		○	
		ON = 0x30, OFF = 0x31				Get			
Fault description (Recoverable faults)	0x89	Fault description	unsigned short	2 bytes	-	Get		○	
		Lower order one byte Restarting the device by performing a reset operation = 0x02 Higher-order one byte Obstacle caught = 0x04 Recovery from outage = 0x05 Time out = 0x06 Battery low = 0x07 0x45 to 0xFF: Defined by user							
Timer operation setting	0x90	Turns the timer operation ON or OFF.	unsigned char	1 byte	-	Set/Get		○	
		ON = 0x41, OFF = 0x42							
Registered temperature detection status	0xC0	Indicates the detection of a registered temperature.	unsigned char	1 byte	-	Get			
		Registered temperature detected = 0x41 Registered temperature not detected = 0x42							
Rain detection status	0xC1	Indicates the detection of rain.	unsigned char	1 byte	-	Get			
		Rain detected = 0x41, Rain not detected = 0x42							
Opening speed setting	0xD0	Used to specify the normal opening speed by three levels.	unsigned char	1 byte	-	Set/Get			
		Low = 0x41, Medium = 0x42, High = 0x43							
Closing speed setting	0xD1	Used to specify the normal closing speed by three levels.	unsigned char	1 byte	-	Set/Get			
		Low = 0x41, Medium = 0x42, High = 0x43							
Operation time setting value	0xD2	Used to specify the operation time in seconds.	unsigned char	1 byte	second	Set/Get			
		0x00 to 0xFF (0 to 253 seconds)							
Automatic operation setting	0xD4	Turns automatic operation ON or OFF.	unsigned char	1 byte	-	Set/Get		○	
		ON = 0x41, OFF = 0x42							

Opening/closing operation setting	0xE0	Open/Close/Stop	unsigned char	1 byte	—	Set/Get	○	○	
		Open = 0x41, Close = 0x42, Stop = 0x43							
Degree-of-opening setting	0xE1	Used to specify the degree-of-opening in %.	unsigned char	1 byte	—	Set/Get			
		0x00 to 0x64 (0 to 100%)							
Opening/closing speed setting	0xE3	Low/Medium/High	unsigned char	1 byte	—	Set/Get			
		Low = 0x41, Medium = 0x42, High = 0x43							
Electric lock setting	0xE5	Locks or unlocks an electric lock.	unsigned char	1 byte	—	Set/Get			
		Lock = 0x41, Unlock = 0x42							
Remote operation setting status	0xE8	Indicates whether remote operation is permitted or prohibited.	unsigned char	1 byte	—	Get		○	
		ON (permitted) = 0x41, OFF (prohibited) = 0x42							
Selective degree-of-opening setting	0xE9	Sets a stop at a specified value.	unsigned char	1 byte	—	Set/Get		○	
		Degree-of-opening setting position: Open = 0x41 Operation time setting value: Open = 0x42 Operation time setting value: Close = 0x43 Local setting position = 0x44 Hereinafter, defined by user (Shortcut to degree-of-opening setting, etc.)							
Open/closed status	0xEA	Indicates the open/closed status.	unsigned char	1 byte	—	Get		○	
		Fully open = 0x41, Fully closed = 0x42, Opening = 0x43, Closing = 0x44, Stopped halfway = 0x45							
One-time opening speed setting	0xEE	Used to specify the speed of single opening operation by three levels.	unsigned char	1 byte	—	Set/Get			
		Low = 0x41, Medium = 0x42, High = 0x43, None = 0x44							
One-time closing speed setting	0xEF	Used to specify the speed of single closing operation by three levels.	unsigned char	1 byte	—	Set/Get			
		Low = 0x41, Medium = 0x42, High = 0x43, None = 0x44							

Note: In the “Announcement at status change” column, ○ denotes mandatory processing when the property is implemented.

(1) Operation status (inherited from the super class property)

This property indicates whether an electrically operated window is ready to accept control commands (ON) or not (OFF). The property value is 0x30 for ON and 0x31 for OFF. If an electrically operated window becomes ready to accept control commands at the start of a node where the electrically operated window class is installed, the value can be fixed at 0x30 at installation.

(2) Fault description (inherited from the device object super class property)

The description here is limited to what are not defined in the super class. This property acquires the description of recoverable faults about an electrically operated window up to the detailed fault classification. The general fault classification shall be fixed at the lower-order byte, and 0x02 indicates a fault that can be recovered from by restarting the device by performing a reset operation in the super class classification. The detailed fault classification shall be fixed at the higher-order byte.

Obstacle caught = 0x04, Recovery from outage = 0x05, Time out = 0x06, Battery low = 0x07, 0x45 to 0xFF are defined by the user

(3) Timer operation setting

The property value is 0x41 (ON) to enable timer operation that starts opening or closing at a time preset to the device or 0x42 (OFF) to disable timer operation. Then the contents of setting are acquired.

(4) Registered temperature detection status

This property indicates whether a preregistered temperature has been reached. The property value is 0x41 when the registered temperature is detected and 0x42 when not.

(5) Rain detection status

This property indicates whether rain has been detected. The property value is 0x41 when rain has been detected and 0x42 when not.

(6) Opening speed setting

This property specifies the speed in the opening direction as a repeatedly available value and indicates the speed by three levels (Low/Medium/High).

(7) Closing speed setting

This property specifies the speed in the closing direction as a repeatedly available value and indicates the speed by three levels (Low/Medium/High).

(8) Operation time setting value

When operation is set by the opening/closing operation setting property (0xE0), this property sets the operation time of an electrically operated window in seconds and acquires the contents of the setting. The operation time is 0 to 253 seconds (0x00 to 0xFD).

(9) Automatic operation setting

The property value is set to 0x41 (ON) to enable the automatic operation of a device supporting automatic operation or 0x42 (OFF) to disable it. Then the contents of setting are acquired.

(10) Opening/closing operation setting

This property sets the opening/closing or stop operation of an electrically operated window and acquires the contents of the setting. The property value is 0x41 for opening, 0x42 for closing, and 0x43 for stop. The target of operation setting by this property is the fully open position after opening and the fully closed position after closing. For a stop at any other position, stop operation shall be set (0x43) during operation or the selective opening operation setting property (0xE9) shall be used.

(11) Degree-of-opening setting

When “Degree-of-opening setting position: Open” (0x41) is set by the selective degree-of-opening property (0xE9), this property sets the degree-of-opening of an electrically operated window within the range from 0 to 100% and acquires the operation result. The property value is 0x00 (Degree-of-opening: 0%) for a status closest to the closed status (not fully closed) and 0x64 (Degree-of-opening: 100%) for a status of the greatest opening (fully open). When the window reaches the target position, the target degree-of-opening setting position shall be returned.

(12) Opening/closing speed setting

This property indicates the opening/closing speed of an automatically operated window by three levels (Low/Medium/High).

(13) Electric lock setting

This property locks or unlocks an electrically operated window and acquires the lock status. The property value is 0x41 for the locked status and 0x42 for the unlocked status.

(14) Remote operation setting status

This property acquires whether an electrically operated window permits or prohibits remote operation from outside. The value is 0x41 (ON) when remote operation from outside is permitted and 0x42 (OFF) when it is prohibited. The value can be fixed at 0x41 (ON) at installation to use an electrically operated window not independently but

always by remote operation.

(15) Selective degree-of-opening setting

This property indicates the setting to operate or stop an electrically operated window as specified by another property or device. The property value is 0x41 for operation by “Degree-of-opening setting” (0xE1), 0x42 for operation in the opening direction by “Operation time setting value” (0xD2), 0x43 for operation in the closing direction by “Operation time setting value” (0xD2), and 0x44 for stop at a position stored independently by the electrically operated window. User definition shall be permitted for a stop by opening level setting using a single signal.

(16) Open/closed status

This property acquires the open/closed status of an electrically operated window. In the fully open status, the window is stopped at the upper limit and the property value is 0x41. In the fully closed status, the window is stopped at the lower limit and the property value is 0x42. In the opening operation status, the window is being operated in the opening direction and the property value is 0x43. In the closing operation status, the window is being operated in the closing direction and the property value is 0x44. When the window is stopped not at the upper or lower limit but halfway, the property value is 0x45.

(17) One-time opening speed setting

This property specifies the speed in the opening direction once only by three levels (Low/Medium/High) and acquires the contents of the setting. The value is 0x41 for low speed, 0x42 for medium speed, 0x43 for high speed, and 0x44 for no setting. After single operation at the speed set by this property, the value changes to 0x44. When the value of this property is 0x44, the operation speed is as set by the opening speed setting property.

(18) One-time closing speed setting

This property specifies the speed in the closing direction once only by three levels (Low/Medium/High) and acquires the contents of the setting. The value is 0x41 for low speed, 0x42 for medium speed, 0x43 for high speed, and 0x44 for no setting. After single operation at the speed set by this property, the value changes to 0x44. When the value of this property is 0x44, the operation speed is as set by the closing speed setting property.

3. 3. 6 Requirements for automatically operated entrance door/sliding door class

Class group code : 0x02

Class code : 0x66

Instance code : 0x01–0x7F (0x00: All-instance specification code)

Property name	EPC	Contents of property	Data type	Data size	Unit	Access rule	Mandatory	Announcement at status change	Remark
		Value range (decimal notation)							
Operation status	0x80	This property indicates the ON/OFF status.	unsigned char	1 byte	—	Set		○	
		ON = 0x30, OFF = 0x31				Get			
Fault description (Recoverable faults)	0x89	Fault description	unsigned short	2 bytes	—	Get		○	
		Lower order one byte Restarting the device by performing a reset operation = 0x02 Higher-order one byte Obstacle caught = 0x04 Recovery from outage = 0x05 Time out = 0x06 Battery low = 0x07 0x45 to 0xFF: Defined by user							
Opening speed setting	0xD0	Used to specify the normal opening speed by three levels.	unsigned char	1 byte	—	Set/Get			
		Low = 0x41, Medium = 0x42, High = 0x43							
Closing speed setting	0xD1	Used to specify the normal closing speed by three levels.	unsigned char	1 byte	—	Set/Get			
		Low = 0x41, Medium = 0x42, High = 0x43							
Operation time setting value	0xD2	Used to specify the operation time in seconds.	unsigned char	1 byte	second	Set/Get			
		0x00 to 0xFD (0 to 253 seconds)							
Opening time setting	0xD5	Used to specify the opening time. MM:SS	unsigned char × 2	2 bytes	—	Set/Get		○	
		0 to 0x3B:0 to 0x3B (= 0 to 59 minutes):(= 0 to 59 seconds) Released = 0xFFFF							
Opening/closing operation setting	0xE0	Open/Close/Stop	unsigned char	1 byte	—	Set/Get	○	○	
		Open = 0x41, Close = 0x42, Stop = 0x43							
Degree-of-opening setting	0xE1	Used to specify the degree-of-opening in %.	unsigned char	1 byte	—	Set/Get			
		0x00 to 0x64 (0 to 100%)							
Opening/closing	0xE3	Low/Medium/High	unsigned	1	—	Set/Get			

g speed setting		Low = 0x41, Medium = 0x42, High = 0x43	char	byte					
Remote operation setting status	0xE8	Indicates whether remote operation is permitted or prohibited.	unsigned char	1 byte	—	Get		○	
		ON (permitted) = 0x41, OFF (prohibited) = 0x42							
Selective degree-of-opening setting	0xE9	Sets a stop at a specified value.	unsigned char	1 byte	—	Set/Get		○	
		Degree-of-opening setting position: Open = 0x41 Operation time setting value: Open = 0x42 Operation time setting value: Close = 0x43 Local setting position = 0x44 Hereinafter, defined by user (Shortcut to degree-of-opening setting, etc.)							
Open/closed status	0xEA	Indicates the open/closed status.	unsigned char	1 byte	—	Get		○	
		Fully open = 0x41, Fully closed = 0x42, Opening = 0x43, Closing = 0x44, Stopped halfway = 0x45							
One-time opening speed setting	0xEE	Used to specify the speed of single opening operation by three levels.	unsigned char	1 byte	—	Set/Get			
		Low = 0x41, Medium = 0x42, High = 0x43, None = 0x44							
One-time closing speed setting	0xEF	Used to specify the speed of single closing operation by three levels.	unsigned char	1 byte	—	Set/Get			
		Low = 0x41, Medium = 0x42, High = 0x43, None = 0x44							

Note: In the “Announcement at status change” column, ○ denotes mandatory processing when the property is implemented.

(1) Operation status (inherited from the super class property)

This property indicates whether an electrically operated entrance door/sliding door is ready to accept control commands (ON) or not (OFF). The property value is 0x30 for ON and 0x31 for OFF. If an electrically operated entrance door/sliding door becomes ready to accept control commands at the start of a node where the electrically operated entrance door/sliding door class is installed, the value can be fixed at 0x30 at installation.

(2) Fault description (inherited from the super class property)

The description here is limited to what are not defined in the super class. This property acquires the description of recoverable faults about an electrically operated entrance door/sliding door up to the detailed fault classification. The general fault classification shall be fixed at the lower-order byte, and 0x02 indicates a fault that can be recovered from by restarting the device by performing a reset operation in the super class

classification. The detailed fault classification shall be fixed at the higher-order byte.

Obstacle caught = 0x04, Recovery from outage = 0x05, Time out = 0x06, Battery low = 0x07, 0x45 to 0xFF are defined by the user

(3) Opening speed setting

This property specifies the speed in the opening direction as a repeatedly available value and indicates the speed by three levels (Low/Medium/High).

(4) Closing speed setting

This property specifies the speed in the closing direction as a repeatedly available value and indicates the speed by three levels (Low/Medium/High).

(5) Operation time setting value

When operation is set by the opening/closing operation setting property (0xE0), this property sets the operation time of an electrically operated entrance door/sliding door in seconds and acquires the contents of the setting. The operation time is 0 to 253 seconds (0x00 to 0xFD).

(6) Opening time setting

This property sets the opening time for an automatically operated entrance door/sliding door that is closed automatically a certain time after opening and acquires the contents of the setting. The data format is MM: 0x00 to 0x3B (0 to 59 min) and SS: 0x00 to 0x3B (0 to 59 s). The property value for no automatic closing (left open) is 0xFFFF.

(7) Opening/closing operation setting

This property sets the opening/closing or stop operation of an electrically operated entrance door/sliding door and acquires the contents of the setting. The property value is 0x41 for opening, 0x42 for closing, and 0x43 for stop. The target of operation setting by this property is the fully open position after opening and the fully closed position after closing. For a stop at any other position, stop operation shall be set (0x43) during operation or the selective degree-of-opening property (0xE9) shall be used.

(8) Degree-of-opening setting

When "Degree-of-opening setting position: Open" (0x41) is set by the selective degree-of-opening property (0xE9), this property sets the degree-of-opening of an electrically operated entrance door/sliding door within the range from 0 to 100% and

acquires the operation result. The property value is 0x00 (Degree-of-opening: 0%) for a status closest to the closed status (not fully closed) and 0x64 (Degree-of-opening: 100%) for a status of the greatest opening (fully open). When the entrance door/sliding door reaches the target position, the target degree-of-opening setting position shall be returned.

(9) Opening/closing speed setting

This property indicates the opening/closing speed of an automatically operated entrance door/sliding door by three levels (Low/Medium/High).

(10) Remote operation setting status

This property acquires whether an electrically operated entrance door/sliding door permits or prohibits remote operation from outside. The value is 0x41 (ON) when remote operation from outside is permitted and 0x42 (OFF) when it is prohibited. The value can be fixed at 0x41 (ON) at installation to use an electrically operated entrance door/sliding door not independently but always by remote operation.

(11) Selective degree-of-opening setting

This property indicates the setting to operate or stop an electrically operated entrance door/sliding door as specified by another property or device. The property value is 0x41 for operation by "Degree-of-opening setting" (0xE1), 0x42 for operation in the opening direction by "Operation time setting value" (0xD2), 0x43 for operation in the closing direction by "Operation time setting value" (0xD2), and 0x44 for stop at a position stored independently by the electrically operated entrance door/sliding door. User definition shall be permitted for a stop by opening level setting using a single signal.

(12) Open/closed status

This property acquires the open/closed status of an electrically operated entrance door/sliding door. In the fully open status, the entrance door/sliding door is stopped at the upper limit and the property value is 0x41. In the fully closed status, the entrance door/sliding door is stopped at the lower limit and the property value is 0x42. In the opening operation status, the entrance door/sliding door is being operated in the opening direction and the property value is 0x43. In the closing operation status, the entrance door/sliding door is being operated in the closing direction and the property value is 0x44. When the entrance door/sliding door is stopped not at the upper or lower limit but halfway, the property value is 0x45.

(13) One-time opening speed setting

This property specifies the speed in the opening direction once only by three levels (Low/Medium/High) and acquires the contents of the setting. The value is 0x41 for low speed, 0x42 for medium speed, 0x43 for high speed, and 0x44 for no setting. After single operation at the speed set by this property, the value changes to 0x44. When the value of this property is 0x44, the operation speed is as set by the opening speed setting property.

(14) One-time closing speed setting

This property specifies the speed in the closing direction once only by three levels (Low/Medium/High) and acquires the contents of the setting. The value is 0x41 for low speed, 0x42 for medium speed, 0x43 for high speed, and 0x44 for no setting. After single operation at the speed set by this property, the value changes to 0x44. When the value of this property is 0x44, the operation speed is as set by the closing speed setting property.

3. 3. 7 Requirements for sprinkler (for garden) class

Class group code: 0x02

Class code: 0x67

Instance code: 0x01 to 0x7F (0x00: All-instance specification code)

Property name	EPC	Contents of property	Data type	Data size	Unit	Access rule	Mandatory	Announcement at status change	Remark
		Value range (decimal notation)							
Operation status	0x80	This property indicates the ON/OFF status.	unsigned char	1 byte	—	Set		○	
		ON=0x30, OFF=0x31				Get			
Sprinkle valve open/close setting	0xE0	Open/close of sprinkle valve	unsigned char	1 byte	—	Set/Get		○	
		Automatic ON=0x40 manual ON=0x41, manual OFF=0x42							
Sprinkle interval setting	0xE1	OFF/daily/every other day/every 3 days/once a week	unsigned long	1 byte	—	Set/Get			
		0x40/0x41/0x42/0x43/0x44							
Number of sprinkles setting	0xE2	Number of sprinkles in a day(up to 2 times) First ON/second ON/both ON	unsigned char	1 byte	—	Set/Get			
		0x41/0x42/0x43							
Sprinkle time setting 1	0xE3	Set timer value HH:MM and get updated time	unsigned char ×2	2 bytes	—	Set/Get			
		0-0x17 : 0-0x3B (=0-23) : (=0-59)							
Sprinkle time setting 2	0xE4	Set timer value HH:MM and get updated time	unsigned char ×2	2 bytes	—	Set/Get			
		0-0x17 : 0-0x3B (=0-23) : (=0-59)							
Sprinkle duration setting	0xE5	Set timer value MM 0 to 59 minutes	unsigned char	1 byte	—	Set/Get			
		0-0x3B (=0-59)							

Note: In the “Announcement at status change” column, ○ denotes mandatory processing when the property is implemented.

(1) Operation status (inherited from the super class property)

This property indicates whether the built-in function of the class is active or not (ON/OFF). For the node equipped with the class, it is possible for the property to be implemented with the fixed value 0x30 (operation status ON) if the function of the class begins to work as the node begins to work,.

(2) Sprinkle valve open/close setting

Sets the electromagnetic valve open/close of a sprinkler and gets open/close status. The 3 settings of automatic ON/manual ON/manual OFF are indicated with

0x40/0x41/0x42. Automatic ON maintains sprinkle valve to be open in the sprinkle the duration (0xE5). Manually open /close of sprinkler electromagnetic valve is set by manual ON or manual OFF.

(3) Sprinkle interval setting

This property indicates sprinkle interval of day (OFF/daily/ every other day/every 3 days/once a week) by 5 steps (0x40/0x41/0x42/0x43/0x44). OFF means no sprinkle.

(4) Number of sprinkles setting

This property indicates the number of sprinkles in a day. The number of sprinkles shall be up to 2 times. ON setting for the first sprinkle and ON setting for the second sprinkle are possible. The 3 steps of first ON/the second ON/the both ON are expressed by 0x41/0x42/0x43. The sprinkle time is set by 0xE3 (the first) and 0xE4 (the second).

(5) Sprinkle time setting 1

This property indicates the sprinkle time setting by hours: 0x00 to 0x17 (0 to 23) and minutes 0x00 to 0x3B (0 to 59). The property value shall begin with the high-order byte in the order of hour, minute.

(6) Sprinkle time setting 2

This property indicates the sprinkle time setting by hours: 0x00 to 0x17 (0 to 23) and minutes 0x00 to 0x3B (0 to 59). The property value shall begin with the high-order byte in the order of hour, minute.

(7) Sprinkle duration setting

This property indicates sprinkle duration and by minutes: 0x00 to 0x3B (0 to 59).

(8) Sprinkle time setting

This property indicates the current time setting by hours: 0x00 to 0x17 (0 to 23) and minutes 0x00 to 0x3B (0 to 59). The property value shall begin with the high-order byte in the order of hour, minute. This property is intended to be used for the purpose of setting the current time corresponds to the time set by ON timer and OFF timer.

(9) Current time setting

This property indicates the current time using by hours: 0x00 to 0x17 (0 to 23) and minutes 0x00 to 0x3B (0 to 59), and to acquire the current setting. The property value shall begin with the high-order byte in the order of hour, minute. This

property shall be effective even when the value of operation status property (0x80) is OFF (0x31).

3. 3. 8 Requirements for electric water heater class

Class group code : 0x02

Class code : 0x6B

Instance code : 0x01 to 0x7F (0x00: All-instance specification code)

Property name	EPC	Contents of property	Data type	Data size	Unit	Access rule	Mandatory	Announcement at status change	Remark
		Value range (decimal notation)							
Operation status	0x80	This property indicates the ON/OFF status.	unsigned char	1 byte	—	Set		○	
		ON = 0x30, OFF = 0x31				Get			
Automatic water heating setting	0xB0	Used to specify whether or not to use the automatic water heating function, and to acquire the current setting.	unsigned char	1 byte	-	Set/Get		○	
		Automatic water heating function used: 0x41 Non-automatic water heating function stopped: 0x43 Non-automatic water heating function used: 0x42							
Automatic water temperature control setting	0xB1	Used to specify whether or not to use the automatic water temperature control function, and to acquire the current setting.	unsigned char	1 byte	-	Set/Get			
		Automatic water temperature control function used: 0x41 Automatic water temperature control function not used: 0x42							
Water heater status	0xB2	This property indicates the current status of the water heater in terms of whether it is heating water or not.	unsigned char	1 byte	-	Get			
		Heating = 0x41 Not heating = 0x42							
Water heating temperature setting	0xB3	Used to specify (in °C) the temperature of heated water to be achieved, and to acquire the current setting.	unsigned char	1 byte	°C	Set/Get			
		0x00-0x64 (0-100°C)							
Manual water heating stop days setting	0xB4	Used to specify manually the number of days to stop "automatic water heating".	unsigned char	1 byte	day	Set/Get			
		0x00-0xFC (= 0-252 days) No time limit: 0xFD							
Relative time setting value for manual water heating OFF	0xB5	Timer value, HH:MM	unsigned char × 2	2 bytes	-	Set/Get			
		0x00-0x17:0x00-0x3B (= 0-23 hours):(= 0-59 minutes)							
Tank operation mode setting	0xB6	Used to specify the setting of operation mode.	unsigned char	1 byte	-	Set/Get			
		Standard = 0x41 Saving = 0x42 Extra = 0x43							

Daytime reheating permission setting	0xC0	Used to specify whether or not to permit daytime reheating, and to acquire the current setting.	unsigned char	1 byte	-	Set/Get	○		
		Daytime reheating permitted: 0x41 Daytime reheating not permitted: 0x42							
Measured temperature of water in water heater	0xC1	This property indicates the current temperature of the water in the water heater.	unsigned char	1 byte	°C	Get			
		0x00-0x64 (0-100°C)							
Alarm status	0xC2	This property indicates the status of an alarm.	unsigned char × 4	4 bytes	-	Get		○	
		First byte: Bit 0: Out of hot water 0 Normal 1 Alarm Bit 1: Water leaking 0 Normal 1 Alarm Bit 2: Water frozen 0 Normal 1 Alarm Bits 3-7: reserved for future use 2-4 bytes: reserved for future use							
Hot water supply status	0xC3	This property indicates the status of supplying hot water.	unsigned char	1 byte	-	Get	○	○	
		Supplying hot water = 0x41 Not supplying hot water = 0x42							
Relative time setting for keeping bath temperature	0xC4	Timer value HH:MM	unsigned char × 2	2 bytes	-	Set/Get			
		0x00-0x17:0x00-0x3B (= 0-23 hours):(= 0-59 minutes)							
Temperature of supplied water setting	0xD1	Used to specify the temperature of water supplied from the water heater in °C, and to acquire the current setting.	unsigned char	1 byte	°C	Set/Get			
		0x00-0x64 (0-100°C)							
Bath water temperature setting	0xD3	Used to specify (in °C) the temperature up to which the water heater will heat bath water, and to acquire the current setting.	unsigned char	1 byte	°C	Set/Get			
		0x00-0x64 (0-100°C)							
Bath water volume setting	0xE0	Used to specify (in %) the volume of bath water the bathtub will contain upon completion of heating, and to acquire the current setting.	unsigned char	1 byte	%	Set/Get			
		0x00-0x64 (0-100%)							
Measured amount of water remaining in tank	0xE1	This property indicates the measured amount of water left in the tank in liters.	unsigned short	2 bytes	liter	Get			
		0x0000-0xFFFFD (0-65533 liters)							
Tank capacity	0xE2	This property indicates the tank capacity in liters.	unsigned short	2 bytes	liter	Get			

		0x0000–0xFFFF (0–65533 liters)							
Automatic bath water heating mode setting	0xE3	Used to specify whether or not to use the “automatic bath water heating” mode, and to acquire the current setting.	unsigned char	1 byte	–	Set/Get	Ⓜ		
		“Automatic bath water heating” mode ON = 0x41 “Automatic bath water heating” mode OFF = 0x42							
Bathroom priority setting	0xE9	Used to specify whether or not to use the function of “priority bathroom.”	unsigned char	1 byte	–	Get			
		Priority bath ON = 0x41 Priority bath OFF = 0x42							
Bath operation status monitor	0xEA	This property indicates the status of bath operation.	unsigned char	1 byte	–	Get		○	
		Filling hot water = 0x41 Stopped = 0x42 Keeping temperature = 0x43							
Manual bath reheating operation setting	0xE4	Used to specify whether or not to use the function to reheat.	unsigned char	1 byte	–	Set/Get			
		Bath reheating ON = 0x41 Bath reheating OFF = 0x42							
Manual bath hot water addition function setting	0xE5	Used to specify whether or not to use the function to add hot water to the bath water in the bathtub, and to acquire the current setting.	unsigned char	1 byte	–	Set/Get			
		“Addition of hot water” function ON = 0x41 “Addition of hot water” function OFF = 0x42							
Manual slight bath water temperature lowering function setting	0xE6	Used to specify whether or not to use the “slight bath water temperature lowering” function, and to acquire the current setting.	unsigned char	1 byte	–	Set/Get			
		“Slight bath water temperature lowering” function ON = 0x41 “Slight bath water temperature lowering” function OFF = 0x42							
Bath water volume setting 1	0xE7	Used to specify the bath water volume in liters, and to acquire the current setting.	unsigned char	1 byte	liter	Set/Get			
		0x00–0xFD (0–253 liters)							
Bath water volume setting 2	0xE8	Used to specify the bath water volume by selecting a level from among the eight predefined levels, and to acquire the current setting.	unsigned char	1 byte	–	Set/Get			
		0x31–0x38							
Bath water volume setting 3	0xEE	Used to specify the bath water volume in liters, and to acquire the current setting.	unsigned short	2 bytes	liter	Set/Get			
		0x0000–0xFFFF (0–65533 liters)							
Bath water volume setting 4	0xD4	The bath hot water volume is specified by a number of steps.	unsigned char	1 byte	–	Set/Get			
		0x01–0xFF							

Bath water volume setting 4- Maximum settable level	0xD5	The maximum settable level is the top step of Bath water volume setting 4.	unsigned char	1 byte	-	Get			
		0x01-0xFF							
ON timer reservation setting	0x90	Reservation ON/OFF	unsigned char	1 byte	liter	Set/Get			
		Reservation ON = 0x41 Reservation OFF = 0x42							
ON timer setting	0x91	ON timer setting (HH:MM)	unsigned char × 2	2 bytes	-	Set/Get			
		0-0x17:0-0x3B (= 0-23):(= 0-59)							
Rated power consumption of H/P unit in wintertime	0xDB	This property indicates the rated power consumption of the heat pump in wintertime (December to March)	unsigned short	2 bytes	W	Get			
		0x0000-0xFFFFD (0-65,533)							
Rated power consumption of H/P unit in in-between seasons	0xDC	This property indicates the rated power consumption of the heat pump in in-between seasons (April, May, October, November)	unsigned short	2 bytes	W	Get			
		0x0000-0xFFFFD (0-65,533)							
Rated power consumption of H/P unit in summertime	0xDD	This property indicates the rated power consumption of the heat pump in summertime (June to September)	unsigned short	2 bytes	W	Get			
		0x0000-0xFFFFD (0-65,533)							

Note: In the “Announcement at status change” column, ○ denotes mandatory processing when the property is implemented.

(1) Operation status (inherited from the device object super class property)

This property indicates whether the function native to this class is operating or not (ON/OFF). In the node mounting this class, if the function of this class is started concurrently with the start of node operation, this property may be implemented at a fixed value of 0x30 (Operation status ON).

(2) Automatic water heating setting

Sets whether the water heating operation in the tank using electric power is performed automatically or not. The automatic water heating function shall be 0x41, the non-automatic water heating function shall be 0x42 and the non-automatic water heating function stopped shall be 0x43.

(3) Automatic water temperature control setting

This property indicates as automatic or non-automatic the temperature value of the electric hot water in the tank depending on the algorithm, etc. Automatic shall be 0x41. Non-automatic shall be 0x42.

(4) Water heater status

This property indicates whether the electric hot water in the tank is presently being

heated or not. Presently heating shall be 0x41. Not heating shall be 0x42.

(5) Water heating temperature setting

This property indicates the °C setting value for heating water in the tank. The property value range is 0x00 to 0x64 (0 to 100°C). 0xFD shall be returned when the “Water heating temperature setting” is unknown or not fixed because the “Automatic water temperature control” setting has been specified.

(6) Manual water heating stop days setting

This property sets the number of days until return to “Automatic water heating” (= 0x41) when “water heating auto setting” (EPC = 0xB0) is “Manual water heating stop” (= 0x43), and acquires the updated number of days. The setting range is 0x00 to 0xFC (0 to 252 days). When the number of days until return to “Automatic water heating” (= 0x41) is infinite, the property value shall be 0xFD. When the property value of the actual device is higher than the upper limit of the value range, the overflow code 0xFF shall be used. When the property value is lower than the lower limit of the value range, the underflow code 0xFE shall be used. This property is valid only when “Water heating auto setting” (EPC = 0xB0) is “Manual water heating stop” (= 0x43).

(7) Relative time setting value for manual water heating OFF

This property indicates the time when “Water heating auto setting” (EPC = 0xB0) returns from “Manual water heating” (= 0x42) to “Automatic water heating” (= 0x41) as a relative time and acquires the updated time. The data format is HH: 0x00 to 0x17 (0 to 23) and MM: 0x00 to 0x3B (0 to 59). The property value is HHMM in order from the highest-order byte. This property is valid only when “Water heating auto setting” (EPC = 0xB0) is “Manual water heating” (= 0x42).

(8) Tank operation mode setting

This property indicates the setting of the operation mode for water heating in the tank. This property is valid only when “Water heating auto setting” (EPC = 0xB0) is “Automatic water heating: 0x41.” The property value is 0x41 for Standard, 0x42 for Saving, and 0x43 for Extra.

Saving: In this mode, less hot water is available than in Standard mode and the power consumption is smaller.

Extra: In this mode, more hot water is available than in Standard mode and the power consumption is greater.

(9) Daytime reheating permission setting

This property indicates permission/prohibition of the permission setting for daytime

reheating of the water in the tank. Daytime reheating permitted shall be 0x41.
 Daytime reheating prohibited shall be 0x42.

(10) Measured temperature of water in water heater

This property indicates the temperature in °C at the present time of hot water inside the tank. The property value range is 0x00 to 0x64 (0 to 100°C).

(11) Alarm status

Out of hot water

If boiling prohibition is set from HEMS or the possibility of a hot water shortage is detected during boiling control, this alarm is output.

Water leaking

If a continuous hot water outflow longer than usual daily use is detected, this alarm is output.

Water frozen

If a possibility of freezing inside equipment or external piping is detected, this alarm is output.

Byte 1:

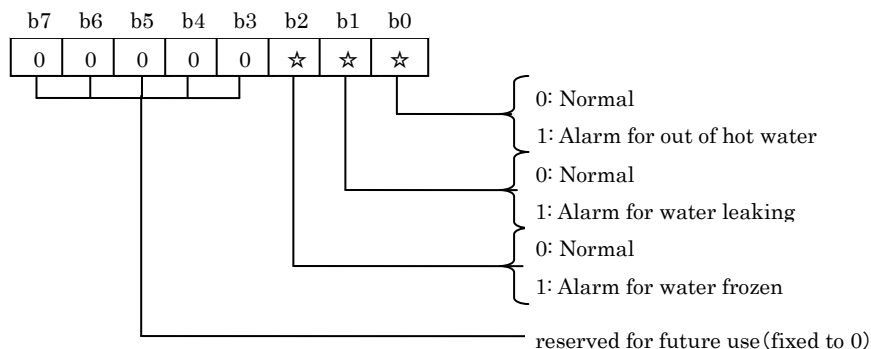

Bytes 2-4:

reserved for future use (fixed to 0)

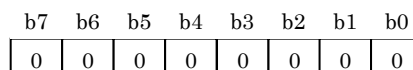

(12) Hot water supply status

This property indicates whether hot water is supplied from a tap in the kitchen or a shower in the bathroom. The property value is 0x41 for “Supplying hot water” and 0x42 for “Not supplying hot water.” This property does not apply to hot water for a bath.

For “Life watching service,” “Announcement at status change” is mandatory.

(13) Relative time setting for keeping bath temperature

This property sets the hot water keeping time of “Bath operation status monitor” (EPC = 0xEA) as a relative value. The data format is HH: 0x00 to 0x17 (0 to 23) and MM: 0x00 to 0x3B (0 to 59). The property value is HHMM in order from the highest-order byte.

(14) Temperature of supplied water setting

This property indicates the temperature setting in °C for the electric water heater supply to a hot water supply terminal. The property value range is 0x00 to 0x64 (0 to 100°C).

(15) Bath water temperature setting

This property indicates the bath water heating temperature setting in °C. The property value range is 0x00 to 0x64 (0 to 100°C).

(16) Bath water volume setting

This property sets the water heating hot water volume as a percentage of the tank capacity. The property value range is 0x00 to 0x64 (0 to 100%).

(17) Measured amount of water remaining in tank

This property indicates the measured amount of water left in the tank in liters. The property value range is 0x0000 to 0xFFFFD (0 to 65,533 liters). When the property value of the actual device is higher than the upper limit of the property value range, the overflow code 0xFFFF shall be used. When the property value is lower than the lower limit of the property value range, the underflow code 0xFFFE shall be used.

(18) Tank capacity

This property indicates the tank capacity in liters. The property value range is 0x0000 to 0xFFFFD (0 to 65533 liters). When the property value of the actual device is higher than the upper limit of the property value range, the overflow code 0xFFFF shall be used. When the property value is lower than the lower limit of the property value range, the underflow code 0xFFFE shall be used.

(19) Automatic bath water heating mode setting

This property indicates whether the bath auto mode is ON or OFF. The property value shall be 0x41 (bath auto mode ON) or 0x42 (bath auto mode OFF). In the case

where a “mobile service” is to be supported, the implementation of this property is mandatory.

(20) Bathroom priority setting

This property indicates whether a water heater is controlled or operated with priority to bath. The property value is 0x41 for Priority to bath ON and 0x42 for Priority to bath OFF. For safety, only Get shall be supported. The contents of priority shall depend on the implementation.

Example of device implementation: When Priority to bath is ON, the temperature of hot water can be changed only from the remote controller in the bathroom. It is prohibited to use the water temperature from any other remote controller or HEMS.

(21) Bath operation status monitor

This property monitors the status of a bath tub in bath auto mode.

When bath auto mode is set (ON: 0x41), the bath tub status is monitored. The property value is 0x41 for “Filling hot water,” 0x43 for “Keeping temperature,” and 0x42 for “Stopped.”

(19) Bath auto mode setting

This property indicates the bath operation status when the bath auto mode is ON.

Filling hot water: Including reheating up to the target temperature after filling

Keeping temperature: Including water adding and reheating while keeping the temperature

Bath operation status monitor indicates “Stopped” when bath auto mode is set to OFF.

(22) Manual bath reheating operation setting

This property indicates whether bath reheating is ON or OFF. The property value is 0x41 for “Bath reheating ON” and 0x42 for “Bath reheating OFF.”

(23) Manual bath hot water addition function setting

This property indicates whether the bath hot water adding operation is ON or OFF. The property value shall be 0x41 (bath hot water adding operation ON) or 0x42 (bath hot water adding operation OFF).

(24) Manual slight bath water temperature lowering function setting

This property indicates whether the bath hot water temperature lowering operation is

ON or OFF. The value 0x41 indicates that the bath hot water temperature lowering operation is ON. The value 0x42 indicates that the bath hot water temperature lowering operation is OFF. When the bath hot water temperature lowering operation is ON, water will be added to the bath to lower the bath hot water temperature.

(22) “Manual bath reheating operation setting,” (23) “Manual bath hot water addition function setting,” and (24) “Manual slight bath water temperature lowering function setting” are possible, irrespective of (19) “Bath auto mode setting,” except when the bath is being filled with hot water.

(25) Bath water volume setting 1

This property indicates the bath hot water volume in liters. The property value range is 0x00 to 0xFD (0 to 253 L). When the property value of the actual device is higher than the property value range, the overflow code 0xFF shall be used. When the property value is lower than the property value range, the underflow code 0xFE shall be used.

(26) Bath water volume setting 2

Sets the bath hot water volume. Eight different levels are available. The values 0x31 and 0x38 represent the minimum and maximum settings, respectively. Specific volume values for the eight different levels are not stipulated.

(27) Bath water volume setting 3

Used to specify the bath water volume in liters, and to acquire the current setting. The property value range is 0x0000 to 0xFFFFD (0 to 65533 liters). When the property value of the actual device is higher than the upper limit of the property value range, the overflow code 0xFFFF shall be used. When the property value is lower than the lower limit of the property value range, the underflow code 0xFFFE shall be used.

(28) Bath water volume setting 4

This property sets the bath water volume. The minimum value is 0x01 and the maximum value is “Bath water volume setting 4 - Maximum settable level.” No actual value is specified for each level. This property is related to “Bath water volume setting 4 - Maximum settable level.”

(29) Bath water volume setting 4 - Maximum settable level

This property indicates the maximum settable level of Bath water volume setting 4. The minimum value is 0x01 and the maximum value is 0xFF. No actual value is

specified for each level. This property is related to “Bath water volume setting 4.”

(30) Rated power consumption of H/P unit in wintertime

This property indicates the rated power consumption of the heat pump in wintertime (to supply hot water at 65°C and water at 9°C) in watts. The property value range is 0x0000 to 0xFFFFD (0 to 65,533). When the property value of the actual device is higher than the upper limit of the value range, 0xFFFF (overflow code) shall be used. When the property value of the actual device is lower than the lower limit of the value range, 0xFFFFE (underflow code) shall be used.

(31) Rated power consumption of H/P unit in in-between seasons

This property indicates the rated power consumption of the heat pump in in-between seasons (to supply hot water at 65°C and water at 17°C) in watts. The property value range is 0x0000 to 0xFFFFD (0 to 65,533). When the property value of the actual device is higher than the upper limit of the value range, 0xFFFF (overflow code) shall be used. When the property value of the actual device is lower than the lower limit of the value range, 0xFFFFE (underflow code) shall be used.

(32) Rated power consumption of H/P unit in summertime

This property indicates the rated power consumption of the heat pump in summertime (to supply hot water at 65°C and water at 24°C) in watts. The property value range is 0x0000 to 0xFFFFD (0 to 65533). When the property value of the actual device is higher than the upper limit of the value range, 0xFFFF (overflow code) shall be used. When the property value of the actual device is lower than the lower limit of the value range, 0xFFFFE (underflow code) shall be used.

(33) ON timer reservation setting

This property indicates whether the bath auto mode reservation is ON or OFF. The property value shall be 0x41 (reservation ON) or 0x42 (reservation OFF). This property is related to the “Set value of ON timer time”.

(34) ON timer setting

When the “ON timer reservation setting” is ON, this property indicates the time at which the bath auto mode setting (EPC = 0xE3) turns ON (0x41). The time is indicated in hours and minutes (hour: 0x00 to 0x17 (0 to 23); minute: 0x00 to 0x3B (0 to 59)). The property value shall sequentially indicate the hour and minute, beginning with the high-order byte.

3. 3. 9 Requirement for the electric toilet seat (warm-water washing toilet seat, heating toilet seat, etc.) class

Class group code : 0x02

Class code : 0x6E

Instance code : 0x01-0x7F (0x00: All-instance specification code)

Property name	EPC	Contents of property	Data type	Data size	Unit	Access rule	Mandatory	Announcement at status change	Remark
		Value range (decimal notation)							
Operation status	0x80	This property indicates the ON/OFF status.	unsigned char	1 byte	—	Set		○	
		ON=0x30, OFF=0x31				Get			
Temperature level of toilet seat	0xE0	Low to high temperature (10 steps) 0x31 for the lowest level, 0x3A for the highest level.	unsigned char	1 byte	—	Set/Get			
		0x31 to 0x3A							
Heater setting of toilet seat	0xE1	ON/OFF	unsigned char	1 byte	-	Set/Get	○		
		ON=0x41, OFF=0x42							
Temporal halt setting of toilet seat	0xE2	Continuous setting/one time setting/no setting.	unsigned char	1 byte	-	Set/Get			
		Continuous setting=0x41, one time setting=0x42, no setting=0x43							
Temporal halt start time of toilet seat	0xE3	Temporal halt start time of toilet seat timer value: HH:MM	unsigned char ×2	2 bytes	-	Set/Get			
		0-0x17 : 0-0x3B (=0-23) : (=0-59)							
Temporal halt time duration of toilet seat	0xE4	Temporal stop time duration of toilet seat timer value: HH:MM	unsigned char ×2	2 bytes	-	Set/Get			
		0-0x17 : 0-0x3B (=0-23) : (=0-59)							
Temperature level setting of room heating	0xE5	Low/medium/high temperature	unsigned char	1 byte	-	Set/Get			
		0x31/0x32/0x33							
Room heating setting	0xE6	Room heating ON/room heating OFF/timer mode setting	unsigned char	1 byte	-	Set/Get			
		0x41/0x42/0x43							
Room heating status	0xE7	Room heating ON/room heating OFF	unsigned char	1 byte	-	Get			
		ON=0x41, OFF=0x42							
Start time of room heating	0xE8	Timer value HH:MM	unsigned char ×2	2 bytes	-	Set/Get			
		0 to 0x17 : 0 to 0x3B (=0 to 23) : (=0 to 59)							
Duration time of room heating	0xE9	Duration time HH:MM	unsigned char ×2	2 bytes	-	Set/Get			
		0-0x17 : 0-0x3B (=0-23) : (=0-59)							
Special operation mode setting	0xEA	Used to set a special operation mode and get the status	unsigned char	1 byte	-	Set/Get			

		No setting: 0x40, Over-cool prevention: 0x41 for future reserved: 0x42-							
Human detection status	0xEB	Indicate detection of human body	unsigned char	1 byte	-	Get			
		Detected = 0x41 Non detected = 0x42							
Seating detection status	0xEC	This property indicates detection of seating	unsigned char	1 byte	-	Get			
		Detected = 0x41 Non detected = 0x42							

Note: In the “Announcement at status change” column, ○ denotes mandatory processing when the property is implemented.

(1) Operation status (inherited from super class property)

This property indicates whether the heating toilet seat can accept the control (ON status) or not (OFF status). The ON status corresponds to 0x30, and the OFF status corresponds to 0x31. For the node equipped with the heating toilet seat class, it is also possible for the property to be implemented with the fixed value 0x30 if the heating toilet seat can accept the control as the node begins to work.

(2) Temperature level of toilet seat

This property indicates 0x31 to 0x3A for the 10 steps of low to high temperature of the toilet seat heating. The lowest level is 0x31 and the highest level is 0x3A. This property shall be effective even when the value of operation status property (0x80) is OFF (0x31).

(3) Heater setting of toilet seat

Sets ON/OFF status for the toilet seat heater. The toilet seat heater ON=0x41 and OFF=0x42.

(4) Temporal halt setting of toilet seat

Sets a temporal halt of the toilet seat and gets the status. There is a continuous setting which the setting is valid at any time, and there is a one time setting which the setting turns to be invalid when the temporal halt is aborted, for the temporal halt setting. The property has relation to “the temporal halt start time of toilet seat” and “the toilet seat temporal halt time duration setting”.

Continuous setting=0x41, one time setting=0x42, no setting=0x43

(5) Temporal halt start time of toilet seat

When the temporal halt setting of toilet seat is continuous or one time setting, The time the toilet seat heater turns OFF is indicated by hours: 0x00 to 0x17(0 to 23) and

minutes 0x00 to 0x3B(0 to 59). The property value shall sequentially indicate the hour and minute, beginning with the high-order byte.

(6) Temporal off time duration of toilet seat

Sets the time from when temporal halt start of the toilet seat heater to when the toilet seat heater turns ON, and gets the status. The data format is hours: 0x00 to 0x17(0 to 23) and minutes 0x00 to 0x3B(0 to 59). The property value shall sequentially indicate the hour and minute, beginning with the high-order byte.

(7) Temperature level setting of room heating

This property indicates setting temperature by 0x31/0x32/0x33 for low/medium/high temperature for the room heating. This property shall be effective even when the value of operation status property (0x80) is OFF (0x31).

(8) Room heating setting

Sets ON/OFF/timer mode of the room heating. The property has relation to “room heating start time setting” or “room heating operation start setting”.

Room heating ON=0x41, room heating OFF=0x42, and timer mode setting=0x43.

(9) Room heating status

Gets the status ON/OFF of room heating.

Room heating ON=0x41, room heating OFF=0x42

(10) Start time of room heating

This property indicates when the room heater turns ON using hours: 0x00 to 0x17(0 to 23) and minutes 0x00 to 0x3B(0 to 59), when the room heating timer mode is set. The property value shall sequentially indicate the hour and minute, beginning with the high-order byte.

(11) Duration time of room heating

This property indicates when the room heater turns ON using the operation time from the start time. The data format is hours: 0x00 to 0x17(0 to 23) and minutes 0x00 to 0x3B(0 to 59). The property value shall sequentially indicate the hour and minute, beginning with the high-order byte.

(12) Special operation mode setting

Sets detail operation mode of the room heating and gets the status. The property value is 0x41 for over-cool prevention or 0x40 for no setting. The possible property values of the actual device as the function shall be only implemented.

This property shall be effective even when the value of operation status property (0x80) is OFF (0x31).

(13) Human detection status

This property indicates the detection of human body, detected/non detected. The property value is maintained until the status changes.

Human body detected=0x41, non detected=0x42

(14) Seating detection status

This property indicates the seating detection. The property value is maintained until the status changes.

Seating detected=0x41, non detected=0x42

3. 3. 10 Requirement for the electric lock class

Class group code : 0x02

Class code : 0x6F

Instance code : 0x01-0x7F (0x00: All-instance specification code)

Property name	EPC	Contents of property	Data type	Data size	Unit	Access rule	Mandatory	Announcement at status change	Remark
		Value range (decimal notation)							
Operation status	0x80	This property indicates the ON/OFF status.	unsigned char	1 byte	—	Set		○	
		ON=0x30, OFF=0x31				Get			
Lock setting 1	0xE0	Lock/unlock of main electric lock	unsigned char	1 byte	—	Set/Get	○	○	
		lock=0x41, unlock=0x42							
Lock setting 2	0xE1	Lock/unlock of sub electric lock	unsigned char	1 byte	-	Set/Get			
		lock=0x41, unlock=0x42							
Lock status of door guard	0xE2	Lock status of door guard.	unsigned char	1 byte	-	Get			
		lock=0x41, unlock=0x42							
Door open/close status	0xE3	Open/close status of door	unsigned char	1 byte	-	Get			
		open=0x41, close=0x42							
Occupant/non-occupant status	0xE4	Occupant/ non-occupant status of persons	unsigned char	1 byte	-	Get			
		occupant=0x41, non-occupant=0x42							
Alarm status	0xE5	Alarm status of electric lock	unsigned char	1 byte	-	Get		○	
		normal (no alarm)=0x40, break open=0x41, door open=0x42, manual unlocked=0x43, tampered=0x44							
Auto lock mode setting	0xE6	Sets ON/OFF of auto lock mode and get the status	unsigned char	1 byte	-	Set/Get			
		ON=0x41, OFF=0x42							
Battery level	0xE7	This property indicates the battery level to get the status of a battery level lower and in need of replacement.	unsigned char	1 byte	-	Set/Get		○	
		Ordinary level=0x40 Notification of battery replacement = 0x41							

Note: In the “Announcement at status change” column, ○ denotes mandatory processing when the property is implemented.

(1) Operation status (inherited from super class property)

This property indicates whether the electric lock can accept the control (ON status) or not (OFF status). The ON status corresponds to 0x30 and the OFF status corresponds to 0x31. For the node equipped with the electric lock class, it is also possible for the property to be implemented with the fixed value 0x30 if the electric lock can accept the control as the node begins to work.

- (2) Lock setting 1
Sets lock/unlock of the main electric lock and gets lock status. The locked status corresponds to 0x41 and the unlocked status corresponds to 0x42.
- (3) Lock setting 2
Sets lock/unlock of the sub electric lock which is mounted on the same door as the main electric lock and gets lock status. The locked status corresponds to 0x41 and the unlocked status corresponds to 0x42.
- (4) Lock status of door guard
Gets the status whether the electric lock is “door guard” status, in which the door can be opened up to a certain slit, or not. The “door guard” status corresponds to 0x41 and the non “door guard” status corresponds to 0x42.
- (5) Door open/close status
Gets open/close status of the door equipped with the main electric lock and the sub electric lock. The open status corresponds to 0x41 and the close status corresponds to 0x42.
- (6) Occupant/ non-occupant status
This property indicates occupant/non-occupant status of persons. The occupant status corresponds to 0x41 and the non-occupant status corresponds to 0x42.
- (7) Alarm status
This property indicates the alarm status. The normal status (no alarm) corresponds to 0x40, break open status corresponds to 0x41, door open status corresponds to 0x42, manual unlocked status corresponds to 0x43, and tampered status corresponds to 0x44. The meanings of individual alarms are shown as follows:
 - Break open: The locked door opened
 - Door open: The door remains open in a certain period of time
 - Manual unlocked: The door was unlocked manually when the door must be unlocked electrically.
 - Tampered: The door was gotten into mischief, removing the cover of the electric lock.
- (8) Auto lock mode setting
Sets ON/OFF of the auto lock mode of electric lock and gets the status. The ON of the auto mode is that the door was automatically locked when the door closes, after

the electric lock is unlocked. The OFF of the auto mode is that the door remains unlocked when the door closes. In other words, the door keeps the status set at the lock setting

(9) Battery level

This property indicates the battery level of an electric lock driven on a battery. Depending on the acquired level, the property indicates 0x40 for an ordinary level and 0x41 for a level lower than the threshold for replacement (notification of battery replacement supported). Then the status is acquired.

3. 3. 11 Requirements for instantaneous water heater class

Class group code : 0x02

Class code : 0x72

Instance code : 0x01-0x7F (0x00: All-instance specification code)

Property name	EPC	Contents of property	Data type	Data size	Unit	Access rule	Mandatory	Announcement at status change	Remark
		Value range (decimal notation)							
Operation status	0x80	This property indicates the ON/OFF status.	unsigned char	1 byte	—	Set		○	
		ON=0x30, OFF=0x31				Get			
Hot water heating status	0xD0	This property indicates the hot water heating status.	unsigned char	1 byte	—	Get		○	
		Hot water heating status found = 0x41 Hot water heating status not found = 0x42							
Set value of hot water temperature	0xD1	This property indicates the set value of the hot water temperature in °C.	unsigned char	1 byte	°C	Get/Set			
		0x00–0x64 (0–100)							
Hot water warmer setting	0xD2	Hot water warmer setting	unsigned char	1 byte	—	Get/Set			
		Hot water warmer operation = 0x41 Hot water warmer operation resetting = 0x42							
“Duration of automatic operation” setting	0xDA	Timer value (HH:MM)	unsigned char × 2	2 bytes	—	Get/Set			
		0–0x17: 0–0x3B (= 0–23): (= 0–59) Limitless: 0xFFFF							
Remaining automatic operation time	0xDB	Timer value (HH:MM)	unsigned char × 2	2 bytes	—	Get			
		0–0x17: 0–0x3B (= 0–23): (= 0–59) Infinite: 0xFFFF							
Set value of bath temperature	0xE1	This property indicates the set value of the bath temperature in °C.	unsigned char	1 byte	°C	Get/Set			
		0x00–0x64 (0–100)							
Bath water heater status	0xE2	This property indicates whether or not the bath water heater is heating the bath water.	unsigned char	1 byte	—	Get		○	
		Heating = 0x41 Not heating = 0x42							
Bath auto mode setting	0xE3	Bath auto mode ON/OFF	unsigned char	1 byte	—	Set/Get			
		Auto ON = 0x41 Auto OFF = 0x42							
Bath additional boil-up operation setting	0xE4	Additional boil-up ON/OFF	unsigned char	1 byte	—	Set/Get			
		Additional boil-up ON = 0x41 Additional boil-up OFF = 0x42							
Bath hot water	0xE5	Hot water addition ON/OFF	unsigned	1 byte	—	Set/Get			

adding operation setting		Hot water addition ON = 0x41 Hot water addition OFF = 0x42	char						
Bath water temperature lowering operation setting	0xE6	Hot water temperature lowering ON/OFF	unsigned char	1 byte	-	Set/Get			
		Hot water temperature lowering ON = 0x41 Hot water temperature lowering OFF = 0x42							
Bath hot water volume setting 1	0xE7	This property indicates bath hot water volume in liters.	unsigned char	1 byte	liters	Set/Get			
		0x00-0xFD (0-253 liters)							
Bath hot water volume setting 2	0xE8	This property indicates the bath hot water volume (in 8 steps).	unsigned char	1 byte	-	Set/Get			
		0x31-0x38							
Bath hot water volume setting 3	0xEE	This property indicates the bath hot water volume in liters.	unsigned short	2 bytes	liter	Set/Get			
		0x0000-0xFFFF (0 to 65533 liters)							
Bath hot water volume setting 4	0xD4	The bath hot water volume is specified by the number of steps.	unsigned char	1 byte	-	Set/Get			
		0x01-0xFF							
Bath hot water volume setting 4 - Maximum settable level	0xD5	The maximum settable level is the top step of Bath hot water volume setting 4.	unsigned char	1 byte	-	Get			
		0x01-0xFF							
Bathroom priority setting	0xE9	Bathroom priority ON/OFF	unsigned char	1 byte	-	Set/Get			
		Bathroom priority ON = 0x41, Bathroom priority OFF = 0x42							
Shower hot water supply status	0xEA	Shower hot water supply ON/OFF	unsigned char	1 byte	-	Get			
		Shower hot water supply ON = 0x41 Shower hot water supply OFF = 0x42							
Kitchen hot water supply status	0xEB	Kitchen hot water supply ON/OFF	unsigned char	1 byte	-	Get			
		Kitchen hot water supply ON = 0x41 Kitchen hot water supply OFF = 0x42							
Hot water warmer ON timer reservation setting	0xEC	Reservation ON/OFF	unsigned char	1 byte	-	Get			
		Reservation ON = 0x41 Reservation OFF = 0x42							
Set value of hot water warmer ON timer time	0xED	Timer value (HH:MM)	unsigned char × 2	2 bytes	-	Set/Get			
		0-0x17:0-0x3B (= 0-23):(= 0-59)							
ON timer reservation setting	0x90	Reservation ON/Reservation OFF	unsigned char	1 byte	-	Set/Get			
		Reservation ON = 0x41 Reservation OFF = 0x42							
Set value of ON timer time	0x91	Timer value (HH:MM)	unsigned char × 2	2 bytes	-	Set/Get			
		0-0x17: 0-0x3B (= 0-23):(= 0-59)							
Set value of ON timer relative time	0x92	Timer value (HH:MM)	unsigned char × 2	2 bytes	-	Set/Get			
		0-0x17: 0-0x3B (= 0-23):(= 0-59)							

Note: In the “Announcement at status change” column, o denotes mandatory processing

when the property is implemented.

This class is intended for use with instantaneous water heaters that use fossil fuels such as gases and kerosene and heat pump-based instantaneous water heaters. For water heaters that heat stored water, it is recommended that the “electric water heater” class (class code = 0x026B) be used. For the purposes of this ECHONET Specification, the term “instantaneous water heaters” shall include both “instantaneous water heaters having a heating unit in which water supplied from a water supply unit is heated by means of heat exchanging” and “instantaneous bath water heaters having a bath water heating unit that heats water or hot water filled in the bathtub by means of heat exchanging by continuously circulating the same water or hot water.” The two types of instantaneous water heaters shall be distinguished by using the terms “water heaters” (or water heating) and “bath water heaters (or bath water heating).” The “addition of hot water” function shall belong to instantaneous water heaters of the former type. If both “water heaters” and “bath water heaters” are indicated, the term “instantaneous water heater” shall be used.

(1) Operation status (inherited from the device object super class property)

This property indicates whether the instantaneous water heater is in the ON state (i.e. the instantaneous water heater responds to user operation) or OFF state. 0x30 and 0x31 shall be used for the ON and OFF states, respectively. In cases where the instantaneous water heater belongs to a node in which the “instantaneous water heater” class is implemented and is ready to respond to user operation as soon as the node starts up, 0x30 may be implemented as the fixed value. When the property value is 0x31 (OFF), values acquired with other properties are not guaranteed, unless otherwise specified in this ECHONET Specification.

(2) Water heating status

This property indicates whether or not the water heater is heating water. 0x41 and 0x42 shall be used for the “heating” and “not heating” states, respectively.

In the case of a heat pump-based water heater, the property value shall be 0x41 (“heating” state) and 0x42 (“not heating” state) when the compressor is in operation and when the compressor is not in operation, respectively.

In cases where the water heater has a separate bath water heater, the “bath water heating status” property (EPC = 0xE2) shall be implemented to indicate whether or not the bath water heater is heating bath water.

(3) Set value of hot water temperature

Used to specify the temperature of water supplied from the water heater to the tap (outlet) unit in °C, and to acquire the current setting. The property value range is

0x00 to 0x64 (0 to 100°C).

(4) Hot water warmer setting

Used to specify whether or not to use the water temperature maintenance function, and to acquire the current setting. 0x41 and 0x42 shall be used for the ON and OFF states, respectively. The water temperature maintenance function shall be defined as a function to maintain the temperature of water in the water heater and the tap (outlet) unit as well as in the section(s) in between using a sub tank or a water circulation system.

(5) “Duration of automatic operation” setting

Used to specify, in terms of a relative time, the period of time between a change in the value of the “Automatic bath water heating mode” setting property (EPC = 0xE3) to 0x41 (ON) and a change back to 0x42 (OFF), and to acquire the current setting. The “hour (0x00 to 0x17 (0 to 23)): minute (0x00 to 0x3B (0 to 59))” format shall be used, with the higher- and lower-order bytes used for the “hour” and “minute” values, respectively.

When the value of this property is “0xFFFF,” the water heating status shall remain at 0x41 for an indefinite period of time.

The value of this property shall not change over time. The remaining time of automatic operation shall be acquired with the “remaining automatic operation time” property (EPC = 0xDB).

(6) Remaining automatic operation time

Used to acquire the time remaining before the value of the “Automatic bath water heating mode” setting property (EPC = 0xE3) changes to 0x42 (OFF). The “hour (0x00 to 0x17 (0 to 23)):minute (0x00 to 0x3B (0 to 59))” format shall be used, with the higher- and lower-order bytes used for the “hour” and “minute” values, respectively.

When the value of this property is “0xFFFF,” the water heating status shall remain at 0x41 for an indefinite period of time.

(7) Set value of bath temperature

Used to specify (in °C) the temperature up to which the water heater will heat bath water, and to acquire the current setting. The property value range is 0x00 to 0x64 (0 to 100°C). When the water heater has a function to maintain the temperature of bath water by adding hot water, this property may also be used to specify and acquire the bath water temperature to be maintained.

(8) Bath water heater status

This property indicates whether or not the bath water heater is heating bath water. 0x41 and 0x42 shall be used for the “heating” and “not heating” states, respectively. The “bath water heater status” property value indicates the status of a separate bath water heater and is independent of the value of the “water heater status” property (EPC = 0xD0).

In the case of a water heater that does not have a bath water heater, the “bath water heater status” property value shall always be 0x42.

In the case of a heat pump-based water heater, the property value shall be 0x41 (“heating” state) and 0x42 (“not heating” state) when the compressor is in operation and when the compressor is not in operation, respectively.

In the case of a water heater with an integrated heat exchanger, this property may be used for the status of the switching valve instead.

(9) Bath auto mode setting

Used to specify whether or not to use the “automatic bath water heating” mode, and to acquire the current setting. 0x41 and 0x42 shall be used for the ON and OFF states, respectively. Because there are wide differences between water heaters in terms of specifications relating to automatic bath water heating functions, the definition of the “automatic bath water heating” mode shall be implementation-dependent. However, an “automatic bath water heating” mode shall normally be a mode in which a series of processes is executed, such as the processes of “filling the bathtub with the specified volume of water, adding hot water as specified, reheating the water as specified and maintaining the temperature of the water at the specified level” or “unplugging the bathtub (draining the used bath water), cleaning the bathtub, plugging the bathtub, filling the bathtub with the specified volume of water, adding hot water as specified, reheating the water as specified and maintaining the temperature of the water at the specified level.” In the case where a “mobile service” is to be supported, the implementation of this property is mandatory.

(10) Bath additional boil-up operation setting

Used to specify whether or not to use the bath water reheating function, and to acquire the current setting. 0x41 and 0x42 shall be used for the ON and OFF states, respectively.

(11) Bath hot water adding operation setting

Used to specify whether or not to use the function to add hot water to the bath water in the bathtub, and to acquire the current setting. 0x41 and 0x42 shall be used for the ON and OFF states, respectively.

(12) Bath water temperature lowering operation setting

Used to specify whether or not to use the “Bath water temperature lowering operation” function, and to acquire the current setting. 0x41 and 0x42 shall be used for the ON and OFF states, respectively. “Bath water temperature lowering operation” shall mean slightly lowering the temperature of the bath water by adding cold water or by using other appropriate means.

(13) Bath hot water volume setting 1

Used to specify the bath water volume in liters, and to acquire the current setting. The property value range is 0x00 to 0xFD (0 to 253 liters). When the property value of the actual piece of equipment is higher than the upper limit of the property value range, the overflow code 0xFF shall be used. When the property value is lower than the lower limit of the property value range, the underflow code 0xFE shall be used. In cases where implementation of the “Bath hot water volume setting 1” property is accompanied by the implementation of the “Bath hot water volume setting 2” property (EPC = 0xE8) or the “Bath hot water volume setting 3” property (EPC = 0xEE), the values of the properties shall be correlated.

(14) Bath hot water volume setting 2

Used to specify the bath water volume by selecting a level from among the eight predefined levels, and to acquire the current setting. The bath water volume values for the eight levels may be defined freely, as long as 0x31 and 0x38 are used for the minimum and maximum volumes, respectively.

In cases where implementation of the “Bath hot water volume setting 2” property is accompanied by the implementation of the “Bath hot water volume setting 1” property (EPC = 0xE7) or the “Bath hot water volume setting 3” property (EPC = 0xEE), the values of the properties shall be correlated.

(15) Bath hot water volume setting 3

Used to specify the bath water volume in liters, and to acquire the current setting. The property value range is 0x0000 to 0xFFFFD (0 to 65533 liters). When the property value of the actual piece of equipment is higher than the upper limit of the property value range, the overflow code 0xFFFF shall be used. When the property value is lower than the lower limit of the property value range, the underflow code 0xFFFFE shall be used.

In cases where implementation of the “Bath hot water volume setting 3” property is accompanied by the implementation of the “Bath hot water volume setting 1” property (EPC = 0xE7) or the “Bath hot water volume setting 2” property (EPC = 0xE8), the values of the properties shall be correlated.

(16) Bath hot water volume setting 4

The bath hot water volume is set by level. The minimum value is 0x01 and the maximum value is "Bath hot water volume setting 4 - Maximum settable level." No actual value is specified for each level. This property is related to "Bath hot water volume setting 4 - Maximum settable level."

(17) Bath hot water volume setting 4 - Maximum settable level

This property indicates the maximum settable level of "Bath hot water volume setting 4." The minimum value is 0x01 and the maximum value is 0xFF. No actual value is specified for each level. This property is related to "Bath hot water volume setting 4."

(18) Bathroom priority setting

Used to specify whether or not to place the water heater in the "Bathroom priority" mode (a mode in which priority is given to bath water heating-related functions, controls and/or user operations), and to acquire the current setting. 0x41 and 0x42 shall be used for the "Bathroom priority" mode and the non-"Bathroom priority" mode, respectively. Determination of the bath water heating-related functions, controls and/or user operations to be given high priority and the manner in which high priority is allocated shall be implementation-dependent.

(19) Shower hot water supply status

This property indicates whether the shower water heating function is used or not (i.e. the shower is being used or not). 0x41 and 0x42 shall be used for the ON and OFF states, respectively.

(20) Kitchen hot water heating status

This property indicates whether the kitchen water heating function is used or not. 0x41 and 0x42 shall be used for the ON and OFF states, respectively.

(21) Hot water warmer ON timer reservation setting

Specifies whether or not to use the water heating/water temperature maintenance reservation function. This property is used in combination with the "Set value of hot water warmer ON timer time" property.

(22) Set value of hot water warmer ON timer time

When the value of the "Hot water warmer ON timer reservation setting" property is "ON," this property indicates, in the "hour (0x00 to 0x17 (0 to 23)):minute (0x00 to 0x3B (0 to 59))" format, the time at which the value of the "Hot water warmer

setting” property (EPC = 0xD2) will change to 0x41 (ON). The higher- and lower-order bytes shall be used for the “hour” and “minute” values, respectively.

(23) ON timer reservation setting

Specifies whether or not to use the “automatic bath water heating mode” reservation function. This property is used in combination with the “Set value of ON timer time” or “Set value of ON timer relative time” property.

(24) Set value of ON timer time

When the value of the “ON timer reservation setting” property is 0x41 (ON), this property indicates, in the “hour (0x00 to 0x17 (0 to 23)):minute (0x00 to 0x3B (0 to 59))” format, the time at which the value of the “Bath auto mode setting” property (EPC = 0xE3) will change to 0x41 (ON). The higher- and lower-order bytes shall be used for the “hour” and “minute” values, respectively.

(25) Set value of ON timer relative time

When the value of the “ON timer reservation setting” property is 0x41 (ON), this property indicates, in terms of a time relative to the current time, the time at which the value of the “Bath auto mode setting” property (EPC = 0xE3) will change to 0x41 (ON). The data format shall be “hour (0x00 to 0x17 (0 to 23)):minute (0x00 to 0x3B (0 to 59)).” The higher- and lower-order bytes shall be used for the “hour” and “minute” values, respectively.

3. 3. 12 Requirements for bathroom heater and dryer class

Class group code : 0x02

Class code : 0x73

Instance code : 0x01–0x7F (0x00: All-instance specification code)

Property name	EPC	Contents of property	Data type	Data size	Unit	Access rule	Mandatory	Announcement at status change	Remark
		Value range (decimal notation)							
Operation status	0x80	This property indicates the ON/OFF status.	unsigned char	1 byte	–	Set	○		
		ON : 0x30 OFF : 0x31				Get			
Operation setting	0xB0	Used to set the operation mode (ventilation mode, bathroom pre-warmer mode, bathroom heater mode, bathroom dryer mode, cool air circulator mode or “stop”), and to acquire the current setting.	unsigned char	1 byte	–	Set/Get	○		
		Ventilation operation : 0x10 Bathroom pre-warmer operation : 0x20 Bathroom heater operation : 0x30 Bathroom dryer operation : 0x40 Cool air circulator operation : 0x50 Stop : 0x00							
Ventilation operation setting	0xB1	Used to set the ventilation air flow rate level for the ventilation mode and to acquire the current setting.	unsigned char	1 byte	–	Set/Get			
		Automatic : 0x41 Standard : 0x42 Air flow rate level : 0x31–0x38							
Bathroom pre-warmer operation setting	0xB2	Used to set the bathroom pre-warming level for the bathroom pre-warmer mode and to acquire the current setting.	unsigned char	1 byte	–	Set/Get	○		
		Automatic : 0x41 Standard : 0x42 Bathroom pre-warming level : 0x31–0x38							
Bathroom heater operation setting	0xB3	Used to set the bathroom heating level for the bathroom heater mode and to acquire the current setting.	unsigned char	1 byte	–	Set/Get			
		Automatic : 0x41 Standard : 0x42 Bathroom heating level : 0x31–0x38							
Bathroom dryer operation setting	0xB4	Used to set the bathroom drying level for the bathroom dryer mode and to acquire the current setting.	unsigned char	1 byte	–	Set/Get	○		
		Automatic : 0x41 Standard : 0x42 Bathroom drying level : 0x31–0x38							

Cool air circulator operation setting	0xB5	Used to set the cool air circulation level for the cool air circulator mode and to acquire the current setting.	unsigned char	1 byte	-	Set/Get			
		Automatic : 0x41 Standard : 0x42 Cool air circulation level : 0x31-0x38							
Measured relative bathroom humidity	0xBA	Used to acquire the measured relative humidity of the bathroom.	unsigned char	1 byte	%	Get			
		0x00-0x64 (0-100%)							
Measured bathroom temperature	0xBB	Used to acquire the measured temperature of the bathroom.	signed char	1 byte	°C	Get			
		0x81-0x7D (-127-+125°C)							
Ventilation air flow rate setting	0xC2	Used to set the air flow rate level for the around-the-clock ventilation function and to acquire the current setting.	unsigned char	1 byte	-	Set/Get			
		Automatic: 0x41 Air flow rate level: 0x31-0x38							
Filter cleaning reminder sign setting	0xCF	Used to set the filter cleaning reminder sign status (lit/not lit) and to acquire the current setting.	unsigned char	1 byte	-	Set/Get			
		Lit: 0x41 Not lit: 0x42							
Human body detection status	0xE0	Used to acquire the human body detection status.	unsigned char	1 byte	-	Get			
		Detected: 0x41 Not detected: 0x42							
“ON timer-based reservation” setting 1	0x90	Used to set the ON/OFF status of the ON timer-based reservation function and to acquire the current setting.	unsigned char	1 byte	-	Set/Get			
		Reservation function ON: 0x41 Reservation function OFF: 0x42							
“ON timer-based reservation” setting 2	0xE1	Used to set the ON/OFF status of the ON timer-based reservation function with the mode in which the device starts operating specified, and to acquire the current setting.	unsigned char	1 byte	-	Set/Get			
		Reservation function ON for the ventilation mode : 0x10 Reservation function ON for the bathroom pre-warmer mode : 0x20 Reservation function ON for the bathroom heater mode : 0x30 Reservation function ON for the bathroom dryer mode : 0x40 Reservation function ON for the cool air circulator mode : 0x50 Reservation function OFF : 0x00							
ON timer setting (time)	0x91	Used to set the time setting for the time-based reservation function for the ON timer (in the HH:MM format) and to acquire the current setting.	unsigned char ×2	2 bytes	-	Set/Get			
		0-0x17: 0-0x3B (= 0-23); (= 0-59)							
ON timer setting (relative time)	0x92	Used to set the relative time setting for the relative time-based reservation function for the ON timer (in the HH:MM format) and to acquire the current setting.	unsigned char ×2	2 bytes	-	Set/Get			

		0-0x17: 0-0x3B (= 0-23): (= 0-59)							
“OFF timer-based reservation” setting	0x94	Used to set the ON/OFF status of the OFF timer-based reservation function and to acquire the current setting.	unsigned char	1 byte	-	Set/Get			
		Reservation function ON: 0x41 Reservation function OFF: 0x42							
OFF timer setting (time)	0x95	Used to set the time setting for the time-based reservation function for the OFF timer (in the HH:MM format) and to acquire the current setting.	unsigned char ×2	2 bytes	-	Set/Get			
		0-0x17: 0-0x3B (= 0-23): (= 0-59)							
OFF timer setting (relative time)	0x96	Used to set the relative time setting for the relative time-based reservation function for the OFF timer (in the HH:MM format) and to acquire the current setting.	unsigned char ×2	2 bytes	-	Set/Get			
		0-0x17: 0-0x3B (= 0-23): (= 0-59)							

Note: In the “Announcement at status change” column, ○ denotes mandatory processing when the property is implemented.

(1) Operation status (The device object super class property is inherited.)

This property indicates whether the bathroom heater and dryer is ready to accept control commands (ON state) or not (OFF state).

The values “0x30” and “0x31” shall be assigned to the ON and OFF states, respectively.

In the case of a node implemented with the bathroom heater and dryer class whose bathroom heater and dryer becomes ready to accept control commands as soon as the node starts operating, this property may be implemented with the property value fixed at “0x30.”

When the property value is “0x31” (OFF), values acquired with other properties are not guaranteed, unless specified otherwise in this ECHONET Specification.

(2) Operation setting

Used to set the bathroom heater and dryer’s operation mode (ventilation mode, bathroom pre-warmer mode, bathroom heater mode, bathroom dryer mode, cool air circulator mode or “stop”), and to acquire the current setting. Each of the operation modes shall be assigned with the respective code value specified below.

- Ventilation operation : 0x10
- Bathroom pre-warmer operation : 0x20
- Bathroom heater operation : 0x30
- Bathroom dryer operation : 0x40
- Cool air circulator operation : 0x50
- Stop : 0x00

It is only required to implement the property values that correspond to the functions supported by the actual device implemented with this class.

This property shall be effective even when the value of the “operation status” property (“0x80”) is OFF (“0x31”).

(3) Ventilation operation setting

Used to set the ventilation air flow rate level for the ventilation mode and to acquire the current setting.

- The property value for the “automatic” state shall be “0x41.” This ECHONET Specification does not specify requirements regarding the functions to be provided in relation to the “automatic” state.
- The property value for the “standard” state shall be “0x42.” The “standard” state is a state in which the standard ventilation air flow rate level setting of the actual device implemented with this class is used.
- In addition, 8 predefined air flow rate levels shall be provided and the property values “0x31” to “0x38” shall be assigned to the 8 levels. The air flow rates that correspond to the 8 levels may be defined freely, as long as the property values “0x31” and “0x38” are assigned to the lowest and highest air flow rates, respectively.

It is only required to implement the property values that correspond to the functions supported by the actual device implemented with this class.

When this property is implemented, setting/acquisition must be possible even when the current setting of the “operation setting” property (“0xB0”) is other than the ventilation mode.

This property shall be effective even when the value of the “operation status” property (“0x80”) is OFF (“0x31”).

(4) Bathroom pre-warmer operation setting

Used to set the bathroom pre-warming level for the bathroom pre-warmer mode and to acquire the current setting.

- The property value for the “automatic” state shall be “0x41.” This ECHONET Specification does not specify requirements regarding the functions to be provided in relation to the “automatic” state.
- The property value for the “standard” state shall be “0x42.” The “standard” state is a state in which the standard bathroom pre-warming level setting of the actual device implemented with this class is used.
- In addition, 8 predefined bathroom pre-warming levels shall be provided and the property values “0x31” to “0x38” shall be assigned to the 8 levels. The bathroom pre-warming strengths that correspond to the 8 levels may be defined freely, as long as the property values “0x31” and “0x38” are assigned to the lowest and

highest bathroom pre-warming strengths, respectively.

It is only required to implement the property values that correspond to the functions supported by the actual device implemented with this class.

When this property is implemented, setting/acquisition must be possible even when the current setting of the “operation setting” property (“0xB0”) is other than the bathroom pre-warmer mode.

This property shall be effective even when the value of the “operation status” property (“0x80”) is OFF (“0x31”).

(5) Bathroom heater operation setting

Used to set the bathroom heating level for the bathroom heater mode and to acquire the current setting.

- The property value for the “automatic” state shall be “0x41.” This ECHONET Specification does not specify requirements regarding the functions to be provided in relation to the “automatic” state.
- The property value for the “standard” state shall be “0x42.” The “standard” state is a state in which the standard bathroom heating level setting of the actual device implemented with this class is used.
- In addition, 8 predefined bathroom heating levels shall be provided and the property values “0x31” to “0x38” shall be assigned to the 8 levels. The bathroom heating strengths that correspond to the 8 levels may be defined freely, as long as the property values “0x31” and “0x38” are assigned to the lowest and highest bathroom heating strengths, respectively.

It is only required to implement the property values that correspond to the functions supported by the actual device implemented with this class.

When this property is implemented, setting/acquisition must be possible even when the current setting of the “operation setting” property (“0xB0”) is other than the bathroom heater mode.

This property shall be effective even when the value of the “operation status” property (“0x80”) is OFF (“0x31”).

(6) Bathroom dryer operation setting

Used to set the bathroom drying level for the bathroom dryer mode and to acquire the current setting.

- The property value for the “automatic” state shall be “0x41.” This ECHONET Specification does not specify requirements regarding the functions to be provided in relation to the “automatic” state.
- The property value for the “standard” state shall be “0x42.” The “standard” state is a state in which the standard bathroom drying level setting of the actual device implemented with this class is used.

- In addition, 8 predefined bathroom drying levels shall be provided and the property values “0x31” to “0x38” shall be assigned to the 8 levels. The bathroom drying strengths that correspond to the 8 levels may be defined freely, as long as the property values “0x31” and “0x38” are assigned to the lowest and highest bathroom drying strengths, respectively.

It is only required to implement the property values that correspond to the functions supported by the actual device implemented with this class.

When this property is implemented, setting/acquisition must be possible even when the current setting of the “operation setting” property (“0xB0”) is other than the bathroom drying mode.

This property shall be effective even when the value of the “operation status” property (“0x80”) is OFF (“0x31”).

(7) Cool air circulator operation setting

Used to set the cool air circulation level for the cool air circulator mode and to acquire the current setting.

- The property value for the “automatic” state shall be “0x41.” This ECHONET Specification does not specify requirements regarding the functions to be provided in relation to the “automatic” state.
- The property value for the “standard” state shall be “0x42.” The “standard” state is a state in which the standard cool air circulation level setting of the actual device implemented with this class is used.
- In addition, 8 predefined cool air circulation levels shall be provided and the property values “0x31” to “0x38” shall be assigned to the 8 levels. The cool air circulation strengths that correspond to the 8 levels may be defined freely, as long as the property values “0x31” and “0x38” are assigned to the lowest and highest cool air circulation strengths, respectively.

It is only required to implement the property values that correspond to the functions supported by the actual device implemented with this class.

When this property is implemented, setting/acquisition must be possible even when the current setting of the “operation setting” property (“0xB0”) is other than the cool air circulator mode.

This property shall be effective even when the value of the “operation status” property (“0x80”) is OFF (“0x31”).

(8) Measured relative bathroom humidity

This property indicates the measured relative bathroom humidity in %.

The property value range shall be “0x00” to “0x64” (0 to 100%). When the property value of the actual device is higher than the property value range, the overflow code value “0xFF” shall be used. When the property value of the actual device is lower

than the property value range, the underflow code value “0xFE” shall be used. When it is not possible to return a measured value, the value “0xFD” shall be used.

This property shall be effective even when the value of the “operation status” property (“0x80”) is OFF (“0x31”).

(9) Measured bathroom temperature

This property indicates the measured bathroom temperature in °C.

The property value range shall be “0x81” to “0x7D” (–127 to +125°C). When the property value of the actual device is higher than the property value range, the overflow code value “0x7F” shall be used. When the property value of the actual device is lower than the property value range, the underflow code value “0x80” shall be used.

When it is not possible to return a measured value, the value “0x7E” shall be used.

This property shall be effective even when the value of the “operation status” property (“0x80”) is OFF (“0x31”).

(10) Human body detection status

This property indicates the human body detection status (human body detection sensor).

Detected : 0x41

Not detected : 0x42

(11) Filter cleaning reminder sign setting

Used to set the filter cleaning reminder sign status (lit/not lit) and to acquire the current setting.

Lit : 0x41

Not lit : 0x42

This property shall be effective even when the value of the “operation status” property (“0x80”) is OFF (“0x31”).

(12) Ventilation air flow rate setting

Used to set the air flow rate level for the around-the-clock ventilation function and to acquire the current setting.

- The property value for the “automatic” state shall be “0x41.”
- In addition, 8 predefined air flow rate levels shall be provided and the property values “0x31” to “0x38” shall be assigned to the 8 levels. The air flow rates that correspond to the 8 levels may be defined freely, as long as the property values “0x31” and “0x38” are assigned to the lowest and highest air flow rates, respectively.

This property shall be effective even when the value of the “operation status” property (“0x80”) is OFF (“0x31”).

(13) “ON timer-based reservation” setting 1

Used to set the ON/OFF status of the ON timer-based reservation function and to acquire the current setting. The mode in which the device starts operating is not specified. This property works in combination with the “ON timer setting (time)” or “ON timer setting (relative time)” property.

Reservation function ON : 0x41

Reservation function OFF : 0x42

This property shall be effective even when the value of the “operation status” property (“0x80”) is OFF (“0x31”).

(14) “ON timer-based reservation” setting 2

Used to set the ON/OFF status of the ON timer-based reservation function with the mode in which the device starts operating specified, and to acquire the current setting. This property works in combination with the “ON timer setting (time)” or “ON timer setting (relative time)” property. Each of the operation modes shall be assigned with the respective code value specified below.

Reservation function ON for the ventilation mode : 0x10

Reservation function ON for the bathroom pre-warmer mode : 0x20

Reservation function ON for the bathroom heater mode : 0x30

Reservation function ON for the bathroom dryer mode : 0x40

Reservation function ON for the cool air circulator mode : 0x50

Reservation function OFF : 0x00

It is only required to implement the property values that correspond to the functions supported by the actual device implemented with this class.

This property shall be effective even when the value of the “operation status” property (“0x80”) is OFF (“0x31”).

(15) ON timer setting (time)

This property indicates, when the ““ON timer-based reservation’ setting 1” or ““ON timer-based reservation’ setting 2” property value is a value for using the time-based reservation function, the time at which the bathroom heater and dryer will be turned on.

The “hour (0x00 to 0x17 (0 to 23)) : minute (0x00 to 0x3B (0 to 59))” format shall be used, with the higher- and lower-order bytes used for the “hour” and “minute” values, respectively.

This property shall be effective even when the value of the “operation status”

property (“0x80”) is OFF (“0x31”).

(16) ON timer setting (relative time)

This property indicates, when the “ON timer-based reservation’ setting 1” or “ON timer-based reservation’ setting 2” property value is a value for using the relative time-based reservation function, the time at which the bathroom heater and dryer will be turned on as a relative time with respect to the current time.

The “hour (0x00 to 0x17 (0 to 23)) : minute (0x00 to 0x3B (0 to 59))” format shall be used, with the higher- and lower-order bytes used for the “hour” and “minute” values, respectively.

This property shall be effective even when the value of the “operation status” property (“0x80”) is OFF (“0x31”).

(17) “OFF timer-based reservation” setting

Used to set the ON/OFF status of the OFF timer-based reservation function. This property works in combination with the “OFF timer setting (time)” or “OFF timer setting (relative time)” property.

Reservation function ON : 0x41

Reservation function OFF : 0x42

This property shall be effective even when the value of the “operation status” property (“0x80”) is OFF (“0x31”).

(18) OFF timer setting (time)

This property indicates, when the “OFF timer-based reservation’ setting” property value is “ON,” the time at which the bathroom heater and dryer will be turned off.

The “hour (0x00 to 0x17 (0 to 23)) : minute (0x00 to 0x3B (0 to 59))” format shall be used, with the higher- and lower-order bytes used for the “hour” and “minute” values, respectively.

This property shall be effective even when the value of the “operation status” property (“0x80”) is OFF (“0x31”).

(19) OFF timer setting (relative time)

This property indicates, when the “OFF timer-based reservation’ setting” property value is “ON,” the time at which the bathroom heater and dryer will be turned off as a relative time with respect to the current time.

The “hour (0x00 to 0x17 (0 to 23)) : minute (0x00 to 0x3B (0 to 59))” format shall be used, with the higher- and lower-order bytes used for the “hour” and “minute” values, respectively.

This property shall be effective even when the value of the “operation status”

property (“0x80”) is OFF (“0x31”).

3. 3. 13 Requirements for household solar power generation class

Class group code : 0x02

Class code : 0x79

Instance code : 0x01–0x7F (0x00: All-instance specification code)

Property name	EPC	Contents of property	Data type	Data size	Unit	Access rule	Mandatory	Announcement at status change	Remark
		Value range (decimal notation)							
Operation status	0x80	This property indicates the ON/OFF status.	unsigned char	1 byte	—	Set		○	
		ON=0x30, OFF=0x31				Get			
System-interconnected type	0xD0	This property indicates system interconnection status	unsigned char	1 byte	–	Get			
		System-interconnected type (reverse power flow acceptable) = 0x00 Independent type = 0x01 System-interconnected type (reverse power flow not acceptable) =0x02							
Measured instantaneous amount of electricity generated	0xE0	This property indicates instantaneous generated power in watts.	unsigned short	2 bytes	W	Get	○		
		0x0000–0xFFFD (0–65,533)							
Measured cumulative amount of electricity generated	0xE1	This property indicates integral electric energy in 0.001 kWh.	unsigned long	4 bytes	0.001 kWh	Get	○		
		0x00000000–0x3B9AC9FF (0–999,999.999 kWh)							
Resetting cumulative amount of electricity generated	0xE2	Resets integral generated electric energy by setting 0x00.	unsigned char	1 byte	–	Set			
		Reset = 0x00							
Measured cumulative amount of electricity sold	0xE3	This property indicates integral value of sold power in 0.001 kWh.	unsigned long	4 bytes	0.001 kWh	Get			
		0x00000000–0x3B9AC9FF (0–999,999.999 kWh)							
Resetting cumulative amount of electricity sold	0xE4	Resets integral sold electric energy by setting 0x00.	unsigned char	1 byte	–	Set			
		Reset = 0x00							
Power generation output limit setting 1	0xE5	Specifies the power generation output as a percentage of the rated power generation output and to acquire the current setting.	unsigned char	1 byte	%	Set/Get			
		0x00–0x64 (0–100%)							
Power generation output limit setting 2	0xE6	Specifies the power generation output in watts and to acquire the current setting.	unsigned short	2 bytes	W	Set/Get			
		0x0000–0xFFFD (0–65,533)							
Limit setting for the amount of electricity sold	0xE7	Specifies, in watts, the amount of electricity sold and to acquire the current setting.	unsigned short	2 bytes	W	Set/Get			

		0x0000–0xFFFF (0–65,533)							
Rated power generation output (System-interconnected)	0xE8	This property indicates the rated power output in the system-interconnected status in watts.	unsigned short	2 bytes	W	Set/Get			
		0x0000–0xFFFF (0–65,533)							
Rated power generation output (Independent)	0xE9	This property indicates the rated power output in the independent status in watts.	unsigned short	2 bytes	W	Set/Get			

Note: In the “Announcement at status change” column, ○ denotes mandatory processing when the property is implemented.

(1) Operation status

This property indicates whether the function native to this class is operating or not (ON/OFF). In the node mounting this class, if the function of this class is started concurrently with the start of node operation, this property may be implemented at a fixed value of 0x30 (Operation status ON).

(2) System-interconnected type

This property indicates the status of interconnection with the current system (system-interconnected type).

System interconnection (reverse power flow acceptable) = 0x00, Independent type = 0x01, System interconnection (reverse power flow not acceptable) = 0x02.

(3) Measured instantaneous amount of electricity generated

This property indicates the instantaneous output in watts. The property value range shall be 0x0000 to 0xFFFF. When the property value of the actual piece of equipment is higher than the upper limit of the property value range, the overflow code 0xFFFF shall be used. When the property value is lower than the lower limit of the property value range, the underflow code 0xFFFE shall be used.

(4) Measured cumulative amount of electricity generated

This property indicates the integral generated electric energy in kWh. The property value range shall be 0x00000000 to 0x3B9AC9FF (0 to 999,999.999 kWh). When the integral electric energy overflows, the property value shall be incremented again from 0x00000000.

(5) Resetting cumulative amount of electricity generated

Resets the integral generated electric energy to zero by setting 0x00.

(6) Measured cumulative amount of electricity sold

This property indicates the integral sold electric energy in kWh. The property value range shall be 0x00000000 to 0x3B9AC9FF (0 to 999,999.999 kWh). When the integral electric energy overflows, the property value shall be incremented again from 0x00000000.

(7) Resetting cumulative amount of electricity sold

Resets the integral generated electric energy to zero by setting 0x00.

(8) Power generation output limit setting 1

Used to specify the power generation output as a percentage of the rated power generation output and to acquire the current setting. The value range for this property is from 0 to 100 (from 0x00 to 0x64), and the unit is %. When the value of this property is 100, no limit is imposed. In the case where it is not possible to limit the power generation output using the value specified by this property, the power generation output shall be limited using a value that is closest to and lower than the value specified by this property.

(9) Power generation output limit setting 2

Used to specify the power generation output in watts and to acquire the current setting. The value range for this property is from 0x0000 to 0xFFFFD (from 0 to 65533). In the case where it is not possible to limit the power generation output using the value specified by this property, the power generation output shall be limited using a value that is closest to and lower than the value specified by this property.

(10) Limit setting for the amount of electricity sold

Used to specify, in watts, the amount of electricity sold and to acquire the current setting. The value range for this property is from 0x0000 to 0xFFFFD (from 0 to 65533). In the case where it is not possible to limit the amount of electricity sold using the value specified by this property, the amount of electricity sold shall be limited using a value that is closest to and lower than the value specified by this property.

(11) Rated power generation output (System-interconnected)

This property indicates the rated power generation output (catalog value) in the system-interconnected status (reverse power flow acceptable or not acceptable) in watts. The value range for this property is from 0x0000 to 0xFFFFD (from 0 to 65,533).

(12) Rated power generation output (Independent)

This property indicates the rated power output (catalog value) in the independent status in watts. The value range for this property is from 0x0000 to 0xFFFFD (from 0 to 65,533).

3. 3. 14 Requirement for cold or hot water heat source equipment class

Class group code : 0x02

Class code : 0x7A

Instance code : 0x01–0x7F (0x00: All-instance specification code)

Property name	EPC	Contents of property	Data type	Data size	Unit	Access rule	Mandatory	Announcement at status change	Remark
		Value range (decimal notation)							
Operation status	0x80	This property indicates the ON/OFF status.	unsigned char	1 byte	—	Set		○	
		ON=0x30, OFF=0x31				Get			
Operation mode setting	0xE0	Set the operation mode of heating (hot water)/cooling (cold water) and gets the status	unsigned char	1 byte	—	Set/Get			
		Heating=0x41, Cooling=0x42							
Water temperature setting 1	0xE1	This property indicates water temperature setting.	unsigned char	1 byte	°C	Set/Get	○		Note1
		0x00–0x64 (0–100°C) AUTO=0x71							
Water temperature setting 2	0xE2	This property indicates water temperature setting level by 15 steps	unsigned char	1 byte	—	Set/Get	○		Note1
		Cooling (cold water):0x21–0x2F Heating (hot water):0x31–0x3F Indicated the minimum to maximum level respectively AUTO=0x41							
Measured temperature of outward water (Exit water Temperature)	0xE3	Measured temperature of outward water	unsigned char	1 byte	°C	Get			
		0x00–0x64 (0–100°C)							
Measured temperature of inward water (Entrance water temperature)	0xE4	Measured temperature of inward water	unsigned char	1 byte	°C	Get			
		0x00–0x64 (0–100°C)							
Special operation setting	0xE5	Sets Normal Operation/ modest operation/high power operation and gets the status	unsigned char	1 byte	—	Set/Get			
		Normal Operation=0x41, modest operation=0x42, high power operation=0x43							
Daily timer setting	0xE6	Daily timer ON/OFF Up to 2 kinds of timers can be used	unsigned char	1 byte	—	Set/Get			
		Timer OFF=0x40, timer 1=0x41 timer 2=0x42							
Daily timer setting 1	0xE7	Time set by daily timer	unsigned char × 6	6 bytes	—	Set/Get			
		Set the time in the unit of 30 minutes, dividing 24 hours by 30 minutes and allocated 6 bytes. Each bit 1: worked 0: stopped							

Daily timer setting 2	0xE8	Time set by daily timer	unsigned char × 6	6 bytes	—	Set/Get			
		Set the time in the unit of 30 minutes, dividing 24 hours by 30 minutes and allocated 6 bytes. Each bit 1: worked 0: stopped							
ON timer reservation setting	0x90	Reservation ON/OFF	unsigned char	1 byte	—	Set/Get			
		ON=0x41, OFF=0x42							
ON timer setting	0x91	Timer value HH:MM	unsigned char × 2	2 bytes	—	Set/Get			
		0-0x17: 0-0x3B (=0-23):(=0-59)							
Relative ON timer setting	0x92	Timer value HH:MM	unsigned char × 2	2 byte	—	Set/Get			
		0-0x17: 0-0x3B (=0-23):(=0-59)							
OFF timer reservation setting	0x94	Reservation ON/OFF	unsigned char	1 byte	—	Set/Get			
		ON=0x41, OFF=0x42							
Time set by OFF timer	0x95	Timer value HH:MM	unsigned char ×2	2 bytes	—	Set/Get			
		0-0x17: 0-0x3B (=0-23):(=0-59)							
Relative OFF timer setting	0x96	Timer value HH:MM	unsigned char ×2	2 bytes	—	Set/Get			
		0-0x17: 0-0x3B (=0-23):(=0-59)							

Note: In the “Announcement at status change” column, ○ denotes mandatory processing when the property is implemented.

Note1: Either “Water temperature setting 1” or “Water temperature setting 2” must be specified.

(1) Operation status (inherited from device object super class property)

This property indicates ON/OFF of the heat source. ON/OFF shall correspond to the property value of 0x30/0x31.

(2) Operation mode setting

Sets operation mode of heating (hot water)/cooling (cold water) and gets the setting status. The mode corresponds to the property value of 0x41/0x42 sequentially. When a heat pump is used as a heat source, the heat source can generate not only hot water for floor heating but also cold water. The property is used for switching of operation mode.

This property shall be effective even when the value of operation status property (0x80) is OFF (0x31).

(3) Water temperature setting 1

This property indicates the setting value of water temperature in degrees in Celsius

and sets the property values to be 0°C to 100°C (0x00 to 0x64).

When this property indicates an automatic operation worked by an algorithm of automatic temperature setting of the heat source equipment, AUTO=0x71 (automatic temperature) is set.

This property shall be effective even when the value of operation status property (0x80) is OFF (0x31).

Either this property or Water temperature setting 2 (0xE2) must be implemented.

(4) Water temperature setting 2

This property indicates the setting value of water temperature by 15 steps and the property value is 0x21 to 0x2F for cooling (cold water) or 0x31 to 0x3F for heating (hot water). Each temperature level does not specify the figures in Celsius, and shall indicate 0x21 or 0x31 for the minimum temperature and 0x2F or 0x3F for the maximum temperature.

When this property indicates an automatic operation worked by an algorithm of automatic temperature setting of the heat source equipment, AUTO=0x41 (automatic temperature) is set.

This property shall be effective even when the value of operation status property (0x80) is OFF (0x31).

Either this property or Water temperature setting 1 (0xE1) must be implemented.

(5) Measured temperature of outward water (exit water temperature)

This property indicates the measured temperature of outward water that goes out of the heat source equipment in Celsius. The range of the property value shall be 0x00 to 0x64 (0 to 100°C). The property value shall be used the overflow code 0x7F when the measured property value of the actual equipment is over the range, and shall be used the underflow code 0x80 when the measured property value of the actual equipment is less the range. 0x7E shall be used when the measured value cannot be returned.

This property shall be effective even when the value of operation status property (0x80) is OFF (0x31).

(6) Measured temperature of inward water (entrance water temperature)

This property indicates the measured temperature of inward water that comes into the heat source in Celsius. The range of the property value shall be 0x00 to 0x64 (0 to 100°C). The property value shall be used the overflow code 0x7F when the measured property value is over the range, and shall be used the underflow code 0x80 when the measured property value is less the range. 0x7E shall be used when the measured value cannot be returned.

This property shall be effective even when the value of operation status property (0x80) is OFF (0x31).

(7) Special operation setting

Sets normal/modest/high power operation and gets the status. This property corresponds to the property value of 0x41/0x42/0x43.

The modest operation temporarily controls at a lower temperature for the water temperature setting value. The high power operation temporarily controls at a higher temperature for the water temperature setting value.

(8) Daily timer setting

Sets ON/OFF of the daily timer and gets the status.

2 kinds of daily timers can be used (for weekdays or holidays, for example).

Timer OFF: 0x40, timer 1 ON: 0x41, timer 2 ON: 0x42.

This property shall be effective even when the value of operation status property (0x80) is OFF (0x31).

(9) Daily timer setting 1

(10) Daily timer setting 2

Set the setting values of the timer 1 and the timer 2 for “daily time setting” and get the status respectively.

24 hours is divided by 30 minutes .The timer is set in the unit of 30 minutes and allocated 6 bytes. 1:operated or 0:stopped is indicated for each bit.

This property shall be effective even when the value of operation status property (0x80) is OFF (0x31).

The 1st byte

b0	b1	b2	b3	b4	b5	b6	b7
0:00 -0:29	0:30 -0:59	1:00 -1:29	1:30 -1:59	2:00 -2:29	2:30 -2:59	3:00 -3:29	3:30 -3:59

The 2nd byte

b0	b1	b2	b3	b4	b5	b6	b7
4:00 -4:29	4:30 -4:59	5:00 -5:29	5:30 -5:59	6:00 -6:29	6:30 -6:59	7:00 -7:29	7:30 -7:59

The 3rd byte

b0	b1	b2	b3	b4	b5	b6	b7
8:00 -8:29	8:30 -8:59	9:00 -9:29	9:30 -9:59	10:00 -10:29	10:30 -10:59	11:00 -11:29	11:30 -11:59

The 4th byte

b0	b1	b2	b3	b4	b5	b6	b7
12:00 -12:29	12:30 -12:59	13:00 -13:29	13:30 -13:59	14:00 -14:29	14:30 -14:59	15:00 -15:29	15:30 -15:59

The 5th byte

b0	b1	b2	b3	b4	b5	b6	b7
16:00 -16:29	16:30 -16:59	17:00 -17:29	17:30 -17:59	18:00 -18:29	18:30 -18:59	19:00 -19:29	19:30 -19:59

The 6th byte

b0	b1	b2	b3	b4	b5	b6	b7
20:00 -20:29	20:30 -20:59	21:00 -21:29	21:30 -21:59	22:00 -22:29	22:30 -22:59	23:00 -23:29	23:30 -23:59

(11) ON timer reservation setting

Sets reservation ON/OFF of the ON timer. This property has relation to “Time set by ON timer” and “Relative ON timer setting”.

Reservation ON=0x41, OFF=0x42.

This property shall be effective even when the value of operation status property (0x80) is OFF (0x31).

(12) Time set by ON timer

This property indicates the ON time of the heat source equipment by hours: 0x00 to 0x17 (0 to 23) and minutes: 0x00 to 0x3B (0 to 59) when “ON timer reservation setting” is ON. The property value shall sequentially indicate the hour and minute, beginning with the high-order byte.

This property shall be effective even when the value of operation status property (0x80) is OFF (0x31).

(13) Relative ON timer setting

This property indicates the ON time of the heat source equipment by relative time from the current time. The data format is hours: 0x00 to 0x17 (0 to 23) and minutes: 0x00 to 0x3B (0 to 59) when “ON timer reservation setting” is ON. The property value shall sequentially indicate the hour and minute, beginning with the high-order byte.

This property shall be effective even when the value of operation status property (0x80) is OFF (0x31).

(14) OFF timer reservation setting

Sets reservation ON/OFF of the OFF timer. This property has relation to “Time set by OFF timer” and “Relative OFF timer setting”.

Reservation ON=0x41, OFF=0x42.

This property shall be effective even when the value of operation status property (0x80) is OFF (0x31).

(15) Time set by OFF timer

This property indicates the OFF time of the heat source equipment by hours: 0x00 to 0x17 (0 to 23) and minutes: 0x00 to 0x3B (0 to 59) when “OFF timer reservation setting” is ON. The property value shall sequentially indicate the hour and minute, beginning with the high-order byte.

This property shall be effective even when the value of operation status property (0x80) is OFF (0x31).

(16) Relative OFF timer setting

This property indicates the OFF time of the heat source equipment by relative time from the current time when “OFF timer reservation setting” is ON. The data format is hours: 0x00 to 0x17 (0 to 23) and minutes: 0x00 to 0x3B (0 to 59). The property value shall sequentially indicate the hour and minute, beginning with the high-order byte.

This property shall be effective even when the value of operation status property (0x80) is OFF (0x31).

3. 3. 15 Requirement for floor heater class

Class group code : 0x02

Class code : 0x7B

Instance code : 0x01–0x7F (0x00: All-instance specification code)

Property name	EPC	Contents of property	Data type	Data size	Unit	Access rule	Mandatory	Announcement at status change	Remark
		Value range (decimal notation)							
Operation status	0x80	This property indicates the ON/OFF status.	unsigned char	1 byte	—	Set	○	○	
		ON=0x30, OFF=0x31				Get	○		
Temperature setting 1	0xE0	This property indicates set temperature	unsigned char	1 byte	°C	Set/Get	○		Note1
		0x00-0x32 (0-50°C) AUTO=0x41							
Temperature setting 2	0xE1	This property indicates set temperature level by 15 steps	unsigned char	1 byte	—	Set/Get	○		Note1
		0x31-0x3F 0x31 indicates the minimum level, 0x3F indicates the maximum level AUTO=0x41							
Measured room temperature	0xE2	Measured room temperature	signed char	1 byte	°C	Get			
		0x81–0x7D (-127–125°C)							
Measured floor temperature	0xE3	Measured floor temperature	signed char	1 byte	°C	Get			
		0x81–0x7D (-127–125°C)							
Zone change setting	0xE4	Sets the target zone for control and gets the number of controllable zones	unsigned char	1 byte		Set/Get			
		b0–b7 is allocated to 0 to 7 Each bit 1: with control, 0: without control							
Special operation setting	0xE5	Sets Normal Operation/modest operation/high power operation and gets the status	unsigned char	1 byte	—	Set/Get			
		Normal Operation=0x41, modest operation=0x42, high power operation=0x43							
Daily timer setting	0xE6	Daily timer ON/OFF Up to 2 kinds of timers can be used	unsigned char	1 byte	—	Set/Get			
		Timer OFF=0x40, timer 1=0x41, timer 2=0x42							
Daily timer setting 1	0xE7	Time set by daily timer	unsigned char × 6	6 bytes	—	Set/Get			
		Set the time in the unit of 30 minutes, dividing 24 hours by 30 minutes and allocated to 6 bytes. Each bit 1: worked 0: stopped							
Daily timer setting 2	0xE8	Time set by daily timer	unsigned char × 6	6 bytes	—	Set/Get			
		Set the time in the unit of 30 minutes, dividing 24 hours by 30 minutes and allocated to 6 bytes. Each bit 1: worked 0: stopped							

ON timer reservation setting	0x90	Reservation ON/OFF	unsigned char	1 byte	—	Set/Get			
		ON=0x41, OFF=0x42							
Time set by ON timer	0x91	Timer value HH:MM	unsigned char × 2	2 bytes	—	Set/Get			
		0-0x17: 0-0x3B (=0-23):(=0-59)							
Relative ON timer setting	0x92	Timer value HH:MM	unsigned char × 2	2 byte	—	Set/Get			
		0-0x17: 0-0x3B (=0-23):(=0-59)							
OFF timer reservation setting	0x94	Reservation ON/OFF	unsigned char	1 byte	—	Set/Get			
		ON=0x41, OFF=0x42							
Time set by OFF timer	0x95	Timer value HH:MM	unsigned char × 2	2 bytes	—	Set/Get			
		0-0x17: 0-0x3B (=0-23):(=0-59)							
Relative OFF timer setting	0x96	Timer value HH:MM	unsigned char × 2	2 bytes	—	Set/Get			
		0-0x17: 0-0x3B (=0-23):(=0-59)							

Note: In the “Announcement at status change” column, ○ denotes mandatory processing when the property is implemented.

Note1: Either “Temperature setting 1 EPC:0xE0” or “Temperature setting 2 EPC:0xE1” must be specified.

(1) Operation status (inherited from device object super class property)

This property indicates ON/OFF of the floor heater. ON/OFF shall correspond to the property value of 0x03/0x31. The access rule “Set” must be implemented for floor heaters.

(2) Temperature setting 1

This property indicates the setting value of temperature in degrees in Celsius and sets the property values to be 0°C to 50°C (0x00 to 0x32).

When this property indicates an automatic operation worked by an algorithm of automatic temperature setting of the floor heater, AUTO=0x41 (automatic temperature) is set.

The temperature means that is controlled by the floor heater (room temperature, floor temperature, etc.) and either kind of temperature can be controlled here.

This property shall be effective even when the value of operation status property (0x80) is OFF (0x31).

Either this property or Temperature setting 2 (0xE1) must be implemented.

(3) Water temperature setting 2

This property indicates the setting value of temperature by 15 steps and the property

value is 0x31 to 0x3F. Each temperature level does not specify the figures in Celsius, and shall indicate 0x31 for the minimum temperature and 0x3F for the maximum temperature.

When this property indicates an automatic operation worked by an algorithm of automatic temperature setting of the floor heater, AUTO=0x41 (automatic temperature) is set.

This property shall be effective even when the value of operation status property (0x80) is OFF (0x31).

Either this property or Temperature setting 1 (0xE0) must be implemented.

(4) Measured room temperature

This property indicates the measured room temperature in Celsius. The range of the property value shall be -127 to 125°C (0x81 to 0x7D). The property value shall be used the overflow code 0x7F when the measured property value is over the range, and shall be used the underflow code 0x80 when the measured property value is less the range. 0x7E shall be used when the measured value cannot be returned. This property shall be effective even when the value of operation status property (0x80) is OFF (0x31).

(5) Measured floor temperature

This property indicates the measured temperature in Celsius. The range of the property value shall be -127 to 125°C (0x81 to 0x7D). The property value shall be used the overflow code 0x7F when the measured property value is over the range, and shall be used the underflow code 0x80 when the measured property value is less the range. 0x7E shall be used when the measured value cannot be returned.

(6) Zone change setting

Sets the target zone and gets the controllable zone when the target floor is divided into zones. The maximum number of zones for the floor is 8 and each zone is explained by a bit map. The b0 to b7 is allocated to the zone 0 to 7. Each bit shall be 1: with control and 0: without control.

This property shall be effective even when the value of operation status property (0x80) is OFF (0x31).

(7) Special operation setting

Sets normal/modest/high power operation and gets the status. This property corresponds to the property value of 0x41/0x42/0x43.

The modest operation temporarily controls at a lower temperature for the temperature setting value at night or at the time of absent. The high power operation temporarily controls at a higher temperature for the water temperature setting value.

(8) Daily timer setting

Sets ON/OFF of the daily timer and gets the status.

2 kinds of daily timers can be used (for weekdays or holidays, for example).

Timer OFF: 0x40, timer 1 ON: 0x41, timer 2 ON: 0x42.

This property shall be effective even when the value of operation status property (0x80) is OFF (0x31).

(9) Daily timer setting 1

(10) Daily timer setting 2

Set the setting values of the timer 1 and the timer 2 for “daily time setting” and get the status respectively.

24 hours is divided by 30 minutes. The timer is set in the unit of 30 minutes and allocated 6 bytes. 1:operated or 0:stopped is indicated for each bit.

This property shall be effective even when the value of operation status property (0x80) is OFF (0x31).

The 1st byte

b0	b1	b2	b3	b4	b5	b6	b7
0:00 -0:29	0:30 -0:59	1:00 -1:29	1:30 -1:59	2:00 -2:29	2:30 -2:59	3:00 -3:29	3:30 -3:59

The 2nd byte

b0	b1	b2	b3	b4	b5	b6	b7
4:00 -4:29	4:30 -4:59	5:00 -5:29	5:30 -5:59	6:00 -6:29	6:30 -6:59	7:00 -7:29	7:30 -7:59

The 3rd byte

b0	b1	b2	b3	b4	b5	b6	b7
8:00 -8:29	8:30 -8:59	9:00 -9:29	9:30 -9:59	10:00 -10:29	10:30 -10:59	11:00 -11:29	11:30 -11:59

The 4th byte

b0	b1	b2	b3	b4	b5	b6	b7
12:00 -12:29	12:30 -12:59	13:00 -13:29	13:30 -13:59	14:00 -14:29	14:30 -14:59	15:00 -15:29	15:30 -15:59

The 5th byte

b0	b1	b2	b3	b4	b5	b6	b7
16:00 -16:29	16:30 -16:59	17:00 -17:29	17:30 -17:59	18:00 -18:29	18:30 -18:59	19:00 -19:29	19:30 -19:59

The 6th byte

b0	b1	b2	b3	b4	b5	b6	b7
----	----	----	----	----	----	----	----

20:00 -20:29	20:30 -20:59	21:00 -21:29	21:30 -21:59	22:00 -22:29	22:30 -22:59	23:00 -23:29	23:30 -23:59
-----------------	-----------------	-----------------	-----------------	-----------------	-----------------	-----------------	-----------------

(11) ON timer reservation setting

Sets reservation ON/OFF of the ON timer. This property has relation to “Time set by ON timer” and “Relative ON timer setting”.

Reservation ON=0x41, OFF=0x42.

This property shall be effective even when the value of operation status property (0x80) is OFF (0x31).

(12) Time set by ON timer

This property indicates the ON time of the floor heater by hours: 0x00 to 0x17 (0 to 23) and minutes: 0x00 to 0x3B (0 to 59) when “ON timer reservation setting” is ON. The property value shall sequentially indicate the hour and minute, beginning with the high-order byte

This property shall be effective even when the value of operation status property (0x80) is OFF (0x31).

(13) Relative ON timer setting

This property indicates the ON time of the floor heater by relative time from the current time. The data format is hours: 0x00 to 0x17 (0 to 23) and minutes: 0x00 to 0x3B (0 to 59) when “ON timer reservation setting” is ON. The property value shall sequentially indicate the hour and minute, beginning with the high-order byte

This property shall be effective even when the value of operation status property (0x80) is OFF (0x31).

(14) OFF timer reservation setting

Sets reservation ON/OFF of the OFF timer. This property has relation to “Time set by OFF timer” and “Relative OFF timer setting”.

Reservation ON=0x41, OFF=0x42.

This property shall be effective even when the value of operation status property (0x80) is OFF (0x31).

(15) Time set by OFF timer

This property indicates the OFF time of the floor heater by hours: 0x00 to 0x17 (0 to 23) and minutes: 0x00 to 0x3B (0 to 59) when “OFF timer reservation setting” is ON. The property value shall sequentially indicate the hour and minute, beginning with the high-order byte

This property shall be effective even when the value of operation status property (0x80) is OFF (0x31).

(16)Relative OFF timer setting

This property indicates the OFF time of the floor heater by relative time from the current time when “OFF timer reservation setting” is ON. The data format is hours: 0x00 to 0x17 (0 to 23) and minutes: 0x00 to 0x3B (0 to 59). The property value shall sequentially indicate the hour and minute, beginning with the high-order byte
This property shall be effective even when the value of operation status property (0x80) is OFF (0x31).

3. 3. 16 Requirements for fuel cell class

Class group code : 0x02
 Class code : 0x7C
 Instance code : 0x01–0x7F (0x00: All-instance specification code)

Property name	EPC	Contents of property	Data type	Data size	Unit	Access rule	Mandatory	Announcement at status change	Remark
		Value range (decimal notation)							
Operation status	0x80	This property indicates the ON/OFF status.	unsigned char	1 byte	–	Set		○	
		ON=0x30, OFF=0x31				Get			
Measured temperature of water in water heater	0xC1	This property indicates the current temperature of the water in the water heater in °C.	unsigned char	1 byte	°C	Get			
		0x00–0x64 (0–100°C)							
Rated power generation output	0xC2	This property indicates the rated power generation output in watts.	unsigned short	2 bytes	W	Get			
		0x0000–0xFFFF (0–65,533W)							
Heating value of hot water storage tank	0xC3	This property indicates the heating value of the hot water storage tank in MJ.	unsigned short	2 bytes	MJ	Get			
		0x0000–0xFFFF (0–65,533MJ)							
Measured instantaneous power generation output	0xC4	This property indicates the instantaneous power generation output in watts.	unsigned short	2 bytes	W	Get	○		
		0x0000–0xFFFF (0–65,533W)							
Measured cumulative power generation output	0xC5	This property indicates the cumulative power generation output in units of 0.001kWh.	unsigned long	4 bytes	0.001 kWh	Get	○		
		0x00000000–0x3B9AC9FF (0–999,999.999kWh)							
Cumulative power generation output reset setting	0xC6	Resets the cumulative power generation output by writing 0x00.	unsigned char	1 byte	–	Set			
		Reset=0x00							
Measured instantaneous gas consumption	0xC7	This property indicates the instantaneous gas consumption in units of 0.001m ³ /h.	unsigned short	2 bytes	0.001 m ³ /h	Get			
		0x0000–0xFFFF (0–65.533m ³ /h)							
Measured cumulative gas consumption	0xC8	This property indicates the cumulative gas consumption in units of 0.001m ³ .	unsigned long	4 bytes	0.001 m ³	Get			
		0x00000000–0x3B9AC9FF (0–999,999.999m ³)							

Cumulative gas consumption reset setting	0xC9	Resets the cumulative gas consumption by writing 0x00.	unsigned char	1 byte	—	Set			
		Reset=0x00							
Power generation setting	0xCA	This property indicates the setting of start or stop of power generation.	unsigned char	1 byte	—	Set/Get			
		Power generation ON=0x41, Power generation OFF=0x42							
Power generation status	0xCB	This property indicates the power generation status.	unsigned char	1 byte	—	Get			
		generating =0x41, stopped=0x42, starting=0x43, stopping=0x44, idling=0x45							
Measured in-house instantaneous power consumption	0xCC	This property indicates the measured in-house instantaneous power consumption in watts.	unsigned short	2 bytes	W	Get			
		0x0000-0xFFFFD (0-65,533W)							
Measured in-house cumulative power consumption	0xCD	This property indicates the measured in-house cumulative power consumption in units of 0.001kWh.	unsigned long	4 bytes	0.001 kWh	Get			
		0x00000000-0x3B9AC9FF (0-999,999.999kWh)							
In-house cumulative power consumption reset	0xCE	This property is set to 0x00 to reset the in-house cumulative power consumption.	unsigned char	1 byte		Set			
		Reset=0x00							
System interconnected type	0xD0	This property indicates the system interconnected type.	unsigned char	1 byte	—	Get			
		System-interconnected type (reverse power flow acceptable)=0x00, Independent type=0x01, System-interconnected type(reverse power flow not acceptable)=0x02							
Measured remaining hot water amount	0xE1	This property indicates the measured amount of remaining hot water in liters.	unsigned short	2 bytes	liter	Get			
		0x0000-0xFFFFD (0-65,533 liters)							
Tank capacity	0xE2	This property indicates the tank capacity in liters.	unsigned short	2 bytes	liter	Get			
		0x0000-0xFFFFD (0-65,533 liters)							

Note: In the “Announcement at status change” column, ○ denotes mandatory processing when the property is implemented.

- (1) Operation status (a property inherited from the device object super class)
This property indicates whether the functions specific to this class are operating (ON) or not (OFF). In the case of a node in which this class is implemented and the functions specific to this class start operating upon startup of the node, this property may be implemented with the value fixed at 0x30 (operation status ON).

- (2) Measured hot water temperature of water heater
This property indicates the current hot water temperature in the hot water storage tank in °C. The property value range is 0x00 to 0x64 (0 to 100°C).
- (3) Rated power generation output
This property indicates the rated power generation output in watts. The property value range is 0x0000 to 0xFFFFD. When the property value of the actual device is higher than the upper bound of the value range, 0xFFFF (overflow code) shall be used. When the property value of the actual device is lower than the lower bound of the value range, 0xFFFFE (underflow code) shall be used.
- (4) Heating value of hot water storage tank
This property indicates the heating value of the hot water storage tank in MJ. The property value range is 0x0000 to 0xFFFFD. When the property value of the actual device is higher than the upper bound of the value range, 0xFFFF (overflow code) shall be used. When the property value of the actual device is lower than the lower bound of the value range, 0xFFFFE (underflow code) shall be used.
- (5) Measured instantaneous power generation output
This property indicates the instantaneous power generation output in watts. The property value range is 0x0000 to 0xFFFFD. When the property value of the actual device is higher than the upper bound of the value range, 0xFFFF (overflow code) shall be used. When the property value of the actual device is lower than the lower bound of the value range, 0xFFFFE (underflow code) shall be used.
- (6) Measured cumulative power generation output
This property indicates the cumulative power generation output in units of 0.001kWh. The property value range is 0x00000000 to 0x3B9AC9FF (0 to 999,999.999 kWh). In the event of a cumulative power generation output overflow, the counting of the cumulative power generation output shall be restarted from 0x00000000.
- (7) Cumulative power generation output reset setting
Resets the cumulative power generation output to zero by setting 0x00.
- (8) Measured instantaneous gas consumption

This property indicates the instantaneous gas consumption in units of 0.001m³/h. The property value range is 0x0000 to 0xFFFFD (0 to 65.533m³/h). When the property value of the actual device is higher than the upper bound of the value range, 0xFFFF (overflow code) shall be used. When the property value of the actual device is lower than the lower bound of the value range, 0xFFFFE (underflow code) shall be used.

(9) Measured cumulative gas consumption

This property indicates the cumulative gas consumption in units of 0.001 m³. The property value range is 0x00000000 to 0x3B9AC9FF (0 to 999,999.999 m³). In the event of a cumulative gas consumption overflow, the counting of the cumulative gas consumption shall be restarted from 0x00000000.

(10) Cumulative gas consumption reset setting

Resets the cumulative gas consumption to zero by setting 0x00.

(11) Power generation setting

This property indicates the setting of power generation by the fuel cell. The property value for power generation ON is 0x41, and the property value for power generation OFF is 0x42.

(12) Power generation status

This property indicates the power generation status of the fuel cell. The property value for generating is 0x41, the property value for stopped is 0x42, the property value for starting is 0x43, the property value for stopping is 0x44 and the property value for idling is 0x45.

(13) Measured in-house instantaneous power consumption

This property indicates the in-house instantaneous power consumption in watts. The property value range is 0x0000 to 0xFFFFD. When the property value of the actual device is higher than the value range of this property, the overflow code 0xFFFF shall be used. When the property value is lower than the value range of this property, the underflow code 0xFFFFE shall be used.

In-house instantaneous power consumption is the sum of power where an anti-reverse power flow CT is installed and the power output.

- (14) Measured in-house cumulative power consumption
This property indicates the in-house cumulative power consumption in units of 0.001kWh. The property value range is 0x00000000 to 0x3B9AC9FF (0 to 999,999.999kWh) and increments again from 0x00000000 in case of a cumulative power consumption overflow.
In-house cumulative power consumption is the sum of power where an anti-reverse power flow CT is installed and the power output.
- (15) In-house cumulative power consumption reset
This property is set to 0x00 to reset the in-house cumulative power consumption to zero.
In-house cumulative power consumption is the sum of power where an anti-reverse power flow CT is installed and the power output.
- (16) System-interconnected type
This property indicates the status of interconnection with the current system (system-interconnected type).
System interconnection (reverse power flow acceptable) = 0x00, Independent type = 0x01, System interconnection (reverse power flow not acceptable) = 0x02.
- (17) Measured remaining hot water amount
This property indicates the amount of hot water remaining in the tank in liters. The property value range is 0x0000 to 0xFFFFD (0 to 65,533 liters). When the property value of the actual device is higher than the upper bound of the value range, 0xFFFF (overflow code) shall be used. When the property value of the actual device is lower than the lower bound of the value range, 0xFFFE (underflow code) shall be used.
- (18) Tank capacity
This property indicates the tank capacity in liters. The property value range is 0x0000 to 0xFFFFD (0 to 65,533 liters). When the property value of the actual device is higher than the upper bound of the value range, 0xFFFF (overflow code) shall be used. When the property value of the actual device is lower than the lower bound of the value range, 0xFFFE (underflow code) shall be used.

3. 3. 17 Requirements for storage battery class

Class group code : 0x02
Class code : 0x7D
Instance code : 0x01–0x7F (0x00: All-instance specification code)

Property name	EPC	Contents of property	Data type	Data size	Unit	Access rule	Mandatory	Announcement at status change	Remark
		Value range (decimal notation)							
Operation status	0x80	This property indicates the ON/OFF status.	unsigned char	1 byte		Set		○	
		ON = 0x30, OFF = 0x31				Get			
Minimum/maximum charging electric energy	0xC8	This property indicates the minimum/maximum electric energy for charging in watts.	unsigned long × 2	8 bytes	W	Get			
		0x00000000–0x3B9AC9FF (0–999,999,999W) Minimum : maximum							
Minimum/maximum discharging electric energy	0xC9	This property indicates the minimum/maximum electric energy for discharging in watts.	unsigned long × 2	8 bytes	W	Get			
		0x00000000–0x3B9AC9FF (0–999,999,999W) Minimum : maximum							
Minimum/maximum charging current	0xCA	This property indicates the minimum/maximum current for charging in units of 0.1A.	unsigned short × 2	4 bytes	0.1A	Get			
		0x0000–0x7FFE (0–3,276.6A) Minimum : maximum							
Minimum/maximum discharging current	0xCB	This property indicates the minimum/maximum current for discharging in units of 0.1A.	unsigned short × 2	4 bytes	0.1A	Get			
		0x0000–0x7FFE (0–3,276.6A) Minimum : maximum							
Working operation status	0xCF	This property indicates the working operation status.	unsigned char	1 byte	—	Get	○	○	
		Rapid charging = 0x41, Charging = 0x42, Discharging = 0x43, Standby = 0x44, Test = 0x45, Other = 0x40							
Rated electric energy	0xD0	This property indicates the rated electric energy of the battery in Wh.	unsigned long	4 bytes	Wh	Get			
		0x00000000–0x3B9AC9FF (0–999,999,999Wh)							
Rated capacity	0xD1	This property indicates the rated charging capacity of the battery in units of 0.1Ah.	unsigned short	2 bytes	0.1Ah	Get			
		0x0000–0x7FFE (0–3,276.6Ah)							
Rated voltage	0xD2	This property indicates the rated voltage of the battery in volts.	unsigned short	2 bytes	V	Get			
		0x0000–0x7FFE (0–32,766V)							

Measured instantaneous charging/discharging electric energy	0xD3	This property indicates the measured instantaneous charging/discharging electric energy in watts (positive/negative).	signed long	4 bytes	W	Get			
		0x00000001–0x3B9AC9FF (1–999,999,999W): during charging (positive value), 0xFFFFFFFF–0xC4653601 (-1–999,999,999W): during discharging (negative value)							
Measured instantaneous charging/discharging current	0xD4	This property indicates the measured instantaneous charging/discharging current in units of 0.1A (positive/negative).	signed short	2 bytes	0.1A	Get			
		0x0001–0x7FFE (0.1–3,276.6A): during charging (positive value), 0xFFFF–0x8001 (-0.1– -3,276.7A): during discharging (negative value)							
Measured instantaneous charging/discharging voltage	0xD5	This property indicates the measured instantaneous charging/discharging voltage in volts (positive/negative).	signed short	2 bytes	V	Get			
		0x0001–0x7FFE (1–32,766V): during charging (positive value), 0xFFFF–0x8001 (-1– -32,767V): during discharging (negative value)							
Measured cumulative discharging electric energy	0xD6	This property indicates the measured cumulative discharging electric energy in units of 0.001kWh.	unsigned long	4 bytes	0.001k Wh	Get			
		0x00000000–0x3B9AC9FF (0–999,999.999kWh)							
“Measured cumulative discharging electric energy” reset setting	0xD7	Resets “Measured cumulative discharging electric energy” to zero.	unsigned char	1 byte	—	Set			
		Reset = 0x00							
Measured cumulative charging electric energy	0xD8	This property indicates the measured cumulative charging electric energy in units of 0.001kWh.	unsigned long	4 bytes	0.001k Wh	Get			
		0x00000000–0x3B9AC9FF (0–999,999.999kWh)							
“Measured cumulative charging electric energy” reset setting	0xD9	Resets “Measured cumulative charging electric energy” to zero.	unsigned char	1 byte	—	Set			
		Reset = 0x00							
Operation mode setting	0xDA	Sets the battery to one of the following operation modes: “Rapid charging,” “Charging,” “Discharging,” “Standby,” “Test,” “Auto” or “Others.”	unsigned char	1 byte	—	Set/Get	○	○	
		Rapid charging = 0x41, Charging = 0x42, Discharging = 0x43, Standby = 0x44, Test = 0x45, Auto = 0x46, Others = 0x40							
System-interconnected type	0xDB	This property indicates the status of connection with the current system (system interconnection status).	unsigned char	1 byte	—	Get			
		System interconnection (reverse power flow acceptable) = 0x00, Independent type = 0x01, System-interconnected type (reverse power flow not acceptable) = 0x02							
Minimum/maximum charging power (Independent)	0xDC	This property indicates the minimum and maximum values of charging power battery in watts in the dependent status.	unsigned long × 2	8 bytes	W	Get			

		0x00000000–0x3B9AC9FF (0–999,999,999W) Minimum charging power: Maximum charging power							
Minimum/maximum discharging power (Independent)	0xDD	This property indicates the minimum and maximum values of discharging power from the battery in the independent status in watts. 0x00000000–0x3B9AC9FF (0–999,999,999W) Minimum discharging power: Maximum discharging power	unsigned long × 2	8 bytes	W	Get			
Minimum/maximum charging current (Independent)	0xDE	This property indicates the minimum and maximum values of a charging current to the battery in the independent status in units of 0.1A. 0x0000–0x7FFE (0–3,276.6A) Minimum charging current: Maximum charging current	unsigned short × 2	4 bytes	0.1A	Get			
Minimum/maximum discharging current (Independent)	0xDF	This property indicates the minimum and maximum values of a discharging current in the independent status in units of 0.1A. 0x0000–0x7FFE (0–3,276.6A) Minimum discharging current: Maximum discharging current	unsigned short × 2	4 bytes	0.1A	Get			
Charging/discharging amount setting 1	0xE0	Used to specify the charging/discharging electric energy in Wh (positive/negative). 0x00000001–0x3B9AC9FF (1–999,999,999Wh): during charging (positive value), 0xFFFFFFFF–0xC4653601 (–1–999,999,999Wh): during discharging (negative value)	signed long	4 bytes	Wh	Set/Get			Note 1
Charging/discharging amount setting 2	0xE1	Used to specify the charging/discharging capacity in units of 0.1Ah (positive/negative). 0x0001–0x7FFD (0.1–3,276.6Ah): during charging (positive value), 0xFFFF–0x8001 (–0.1–3,276.7Ah): during discharging (negative value)	signed short	2 bytes	0.1Ah	Set/Get			Note 1
Remaining stored electricity 1	0xE2	This property indicates the remaining stored electric energy in Wh. 0x00000000–0x3B9AC9FF (0–999,999,999Wh)	unsigned long	4 bytes	Wh	Get	○		Note 2
Remaining stored electricity 2	0xE3	This property indicates the remaining capacity in units of 0.1Ah. 0x0000–0x7FFE (0–3,276.6Ah)	unsigned short	2 bytes	0.1Ah	Get	○		Note 2
Remaining stored electricity 3	0xE4	This property indicates the charging rate of the battery in %. 0x00–0x64 (0–100%)	unsigned char	1 byte	%	Get	○		Note 2
Battery state of health	0xE5	This property indicates the battery state of health in %. 0x00–0x64 (0–100%)	unsigned char	1 byte	%	Get			
Battery type	0xE6	This property indicates the battery type. Type = 0x00–0xFF	unsigned char	1 byte		Get	○		
Charging amount setting 1	0xE7	This property specifies the charging electric energy in Wh.	unsigned long	4 bytes	Wh	Set/Get			Note 3

		0x00000000–0x3B9AC9FF (0–999,999,999Wh)							
Discharging amount setting 1	0xE8	This property specifies the discharging electric energy in Wh.	unsigned long	4 bytes	Wh	Set/Get			Note 4
		0x00000000–0x3B9AC9FF (0–999,999,999Wh)							
Charging amount setting 2	0xE9	This property specifies the charging capacity in units of 0.1Ah.	unsigned short	2 bytes	0.1Ah	Set/Get			Note 3
		0x0000–0x7FFE (0–3,276.6Ah)							
Discharging amount setting 2	0xEA	This property specifies the discharging capacity in units of 0.1Ah.	unsigned short	2 bytes	0.1Ah	Set/Get			Note 4
		0x0000–0x7FFE (0–3,276.6Ah)							
Charging electric energy setting	0xEB	This property specifies the charging electric energy in watts.	unsigned long	4 bytes	W	Set/Get			
		0x00000000–0x3B9AC9FF (0–999,999,999Wh)							
Discharging electric energy setting	0xEC	This property specifies the discharging electric energy in watts.	unsigned long	4 bytes	W	Set/Get			
		0x00000000–0x3B9AC9FF (0–999,999,999Wh)							
Charging current setting	0xED	This property specifies the charging current in units of 0.1A.	unsigned short	2 bytes	0.1A	Set/Get			
		0x0000–0xFFFD (0–6,553.3A)							
Discharging current setting	0xEE	This property specifies the discharging current in units of 0.1A.	unsigned short	2 bytes	0.1A	Set/Get			
		0x0000–0xFFFD (0–6,553.3A)							
Rated voltage (Independent)	0xEF	This property indicates the rated voltage of a battery in the independent status in volts.	unsigned short	2 bytes	V	Get			
		0x0000–0x7FFE (0–32,766V)							

Note: In the “Announcement at status change” column, ○ denotes mandatory processing when the property is implemented.

Note 1: When Charging/discharging amount setting 1 (or 2) is used, Charging/discharging amount setting 2 (or 1), Charging amount setting 1, Discharging amount setting 1, Charging amount setting 2, and Discharging amount setting 2 shall not be used.

Note 2: It is mandatory to install Remaining stored electricity 1, Remaining stored electricity 2, or Remaining stored electricity 3.

Note 3: When Charging amount setting 1 (or 2) is used, Charging amount setting 2 (or 1) and Charging/discharging amount setting 1 and 2 shall not be used.

Note 4: When Discharging amount setting 1 (or 2) is used, Discharging amount setting 2 (or 1) and Charging/discharging amount setting 1 and 2 shall not be used.

In this class, electric current, voltage, and energy values shall be those of AC. The figure below shows an example configuration.

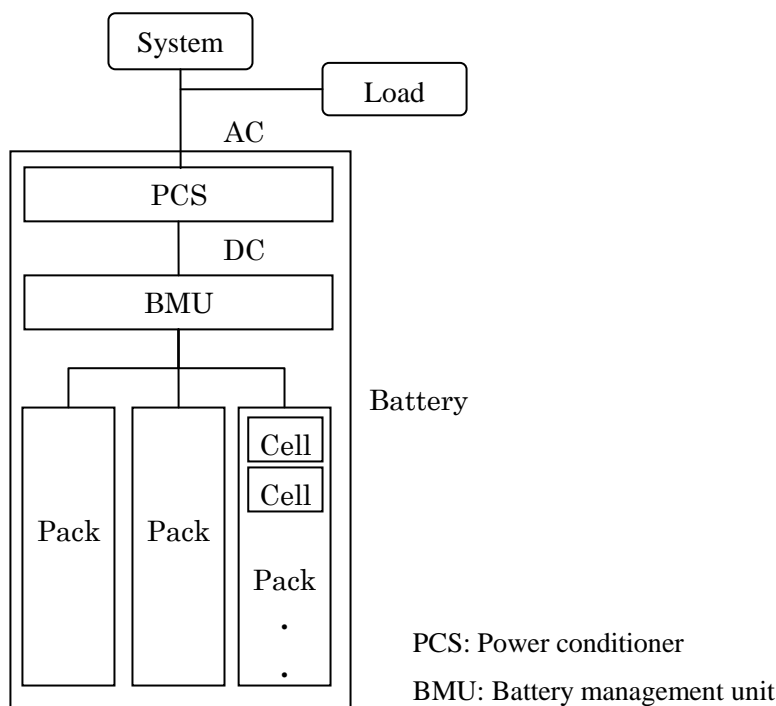

- (1) Operation status (a property inherited from the device object super class)
This property indicates whether the functions specific to this class are operating (ON) or not (OFF). In the case of a node in which this class is implemented and the functions specific to this class start operating upon startup of the node, this property may be implemented with the value fixed at 0x30 (operation status ON).
- (2) Minimum/maximum charging electric energy
This property indicates the minimum/maximum electric energy for charging in watts when the system-interconnected status is system-interconnected (reverse power flow acceptable) or system-interconnected (reverse power flow not acceptable). The property value range is 0x00000000 to 0x3B9AC9FF (0 to 999,999,999W) and the property value shall be derived from the high-order bytes in order of minimum and maximum. When the property value of the actual device is higher than the upper limit of the value range, 0xFFFFFFFF (overflow code) shall be used. If the charging function is not supported, the value shall be 0. When the “Minimum/maximum charging power (independent)” property (EPC = 0xDC) is not used, the value of this property may also be used as the value in the independent status.
- (3) Minimum/maximum discharging electric energy

This property indicates the minimum/maximum electric energy for discharging in watts when the system-interconnected status is system-interconnected (reverse power flow acceptable) or system-interconnected (reverse power flow not acceptable). The value range of the property shall be from 0x00000000 to 0x3B9AC9FF (0 to 999,999,999W) and the property value shall be derived from the high-order bytes in order of minimum and maximum. When the property value of the actual device is higher than the upper limit of the value range, 0xFFFFFFFF (overflow code) shall be used. If the discharging function is not supported, the value shall be 0. When the “Minimum/maximum discharging power (independent)” property (EPC = 0xDD) is not used, the value of this property may also be used as the value in the independent status.

(4) Minimum/maximum charging current

This property indicates the minimum/maximum current for charging in units of 0.1A when the system-interconnected status is system-interconnected (reverse power flow acceptable) or system-interconnected (reverse power flow not acceptable). The property value range is 0x0000 to 0x7FFE (0 to 3,276.6A) and the property value shall be derived from the high-order bytes in order of minimum and maximum. When the property value of the actual device is higher than the upper limit of the value range, 0xFFFF (overflow code) shall be used. If the charging function is not supported, the value shall be 0. When the “Minimum/maximum charging current (independent)” property (EPC = 0xDE) is not used, the value of this property may also be used as the value in the independent status.

(5) Minimum/maximum discharging current

This property indicates the minimum/maximum current for discharging in units of 0.1A when the system-interconnected status is system-interconnected (reverse power flow acceptable) or system-interconnected (reverse power flow not acceptable). The property value range is from 0x0000 to 0x7FFE (0 to 3,276.6A) and the property value shall be derived from the high-order bytes in order of minimum and maximum. When the property value of the actual device is higher than the upper limit of the value range, 0xFFFF (overflow code) shall be used. If the discharging function is not supported, the value shall be 0. When the “Minimum/maximum discharging current (independent)” property (EPC = 0xDF) is not used, the value of this property may also be used as the value in the independent status.

(6) Working operation status

This property indicates the storage battery working operation status as Rapid charging (0x41), Charging (0x42), Discharging (0x43), Standby (0x44), Test (0x45), or Other (0x40). The Charging, Discharging, and Standby operation modes are

mandatory.

(7) Rated electric energy

This property indicates the rated electric energy (catalog value) in Wh. The property value range is 0x00000000 to 0x3B9AC9FF (0 to 999,999,999Wh).

(8) Rated capacity

This property indicates the rated capacity (catalog value) in increments of 0.1Ah. The property value range is 0x0000 to 0x7FFE (0 to 3,276.6Ah).

(9) Rated voltage

This property indicates the rated voltage (catalog value) in volts when the system-interconnected status is system-interconnected (reverse power flow acceptable) or system-interconnected (reverse power flow not acceptable). The property value range is 0x0000 to 0x7FFE (0 to 32,766V). When the “Rated voltage (independent)” property (EPC = 0xEF) is not used, the value of this property may also be used as the value in the independent status.

(10) Measured instantaneous charging/discharging electric energy

This property indicates the measured instantaneous charging/discharging electric energy in watts. The property value range is 0x00000001 to 0x3B9AC9FF (1 to 999,999,999W) for charging and 0xFFFFFFFF to 0xC4653601 (-1 to -999,999,999W) for discharging. When the property value of the actual device is higher than the upper limit of the value range, 0x7FFFFFFF (overflow code) shall be used. When the property value of the actual device is lower than the lower limit of the value range, 0x80000000 (underflow code) shall be used. When neither charging nor discharging is being performed, the property value shall be 0.

(11) Measured instantaneous charging/discharging current

This property indicates the measured instantaneous charging/discharging current in units of 0.1A. The property value range is 0x0001 to 0x7FFE (0.1 to 3,276.6A) for charging and 0xFFFF to 0x8001 (-0.1 to -3,276.7A) for discharging. When the property value of the actual device is higher than the upper limit of the value range, 0x7FFF (overflow code) shall be used. When the property value of the actual device is lower than the lower limit of the value range, 0x8000 (underflow code) shall be used. When neither charging nor discharging is being performed, the property value shall be 0.

(12) Measured instantaneous charging/discharging voltage

This property indicates the measured instantaneous charging/discharging voltage in volts. The property value range is 0x0001 to 0x7FFE (1 to 32,766V) for charging and 0xFFFF to 0x8001 (-1 to -32,767V) for discharging. When the property value of the actual device is higher than the upper limit of the value range, 0x7FFF (overflow code) shall be used. When the property value of the actual device is lower than the lower limit of the value range, 0x8000 (underflow code) shall be used. When neither charging nor discharging is being performed, the property value shall be 0.

(13) Measured cumulative discharging electric energy

This property indicates the measured cumulative discharging electric energy in units of 0.001kWh. The property value range is 0x00000000 to 0x3B9AC9FF (0 to 999,999.999kWh). In the event of a cumulative discharging electric energy overflow, the counting of the cumulative discharging electric energy shall be restarted from 0x00000000.

(14) “Measured cumulative discharging electric energy” resetting

Resets “Measured cumulative discharging electric energy” to zero by setting 0x00.

(15) Measured cumulative charging electric energy

This property indicates the measured cumulative charging electric energy in units of 0.001kWh. The property value range is 0x00000000 to 0x3B9AC9FF (0 to 999,999.999kWh). In the event of a cumulative charging electric energy overflow, the counting of the cumulative charging electric energy shall be restarted from 0x00000000.

(16) “Measured cumulative charging electric energy” resetting

Resets “Measured cumulative charging electric energy” to zero by setting 0x00.

(17) Operation mode setting

This property indicates the operation mode. The property value shall be 0x41 (Rapid charging), 0x42 (Charging), 0x43 (Discharging), 0x44 (Standby), 0x45 (Test), 0x46 (Auto) or 0x40 (Others). “Auto” is the mode where the storage battery is assumed to operate autonomously. The implementation of operation modes such as charging/discharging and standby mode is mandatory.

(18) System-interconnected type

This property indicates the status of interconnection with the current system (system-interconnected type).

System interconnection (reverse power flow acceptable) = 0x00, Independent type =

0x01, System interconnection (reverse power flow not acceptable) = 0x02

(19) Minimum/maximum charging power (Independent)

This property indicates the minimum and maximum values of charging power in watts when the system-interconnected type is independent. The range of each value is 0x00000000 to 0x3B9AC9FF (0 to 999,999,999W). From the higher-order bytes, the property value shall be in order of minimum and maximum values. When the property value of the actual device is higher than the value range of this property, the overflow code 0xFFFFFFFF shall be used. If no charging function is supported, the value shall be 0. When this property is not used, the “Minimum/maximum charging power (independent)” property (EPC = 0xC8) may be used.

(20) Minimum/maximum discharging power (Independent)

This property indicates the minimum and maximum values of charging power in watts when the system-interconnected type is independent. The range of each value is 0x00000000 to 0x3B9AC9FF (0 to 999,999,999W). From the higher-order bytes, the property value shall be in order of minimum and maximum values. When the property value of the actual device is higher than the value range of this property, the overflow code 0xFFFFFFFF shall be used. If no discharging function is supported, the value shall be 0. When this property is not used, the “Minimum/maximum discharging power (independent)” property (EPC = 0xC9) may be used.

(21) Minimum/maximum charging current (Independent)

This property indicates the minimum and maximum values of charging current in units of 0.1A when the system-interconnected type is independent. The range of each value is 0x0000 to 0x7FFE (0 to 3,276.6A). From the higher-order bytes, the property value shall be in order of minimum and maximum values. When the property value of the actual device is higher than the value range of this property, the overflow code 0xFFFF shall be used. If no charging function is supported, the value shall be 0. When this property is not used, the “Minimum/maximum charging current (independent)” property (EPC = 0xCA) may be used.

(22) Minimum/maximum discharging current (Independent)

This property indicates the minimum and maximum values of discharging current in units of 0.1A when the system-interconnected type is independent. The range of each value is 0x0000 to 0x7FFE (0 to 3,276.6A). From the higher-order bytes, the

property value shall be in order of minimum and maximum values. When the property value of the actual device is higher than the value range of this property, the overflow code 0xFFFF shall be used. If no discharging function is supported, the value shall be 0. When this property is not used, the “Minimum/maximum discharging current (independent)” property (EPC = 0xCB) may be used.

(23) Charging/discharging amount setting 1

Specifies the charging/discharging electric energy in Wh (positive/negative). (Note that this property does not specify the battery level after charging or discharging.) The property value range is 0x00000001 to 0x3B9AC9FF (1 to 999,999,999Wh) for charging and 0xFFFFFFFF to 0xC4653601 (-1 to -999,999,999Wh) for discharging. The charging/discharging status will not affect the value. When charging/discharging is completed, the operation mode changes to Standby. For complete charging, this value shall be set equal to or greater than the rated electric energy. For complete discharging, this value shall be set equal to or greater than the rated electric energy with the negative sign.

(24) Charging/discharging amount setting 2

Specifies the charging/discharging capacity in units of 0.1Ah (positive/negative). (Note that this property does not specify the battery level after charging or discharging.) The property value range is 0x0001 to 0x7FFE (0.1 to 3,276.6Ah) for charging and 0xFFFF to 0x8001 (-0.1 to -3,276.7Ah) for discharging. The charging/discharging status will not affect the value. When charging/discharging is completed, the operation mode changes to Standby. For complete charging, this value shall be set equal to or greater than the rated electric energy. For complete discharging, this value shall be set equal to or greater than the rated electric energy with the negative sign.

(25) Remaining stored electricity 1

This property indicates the remaining stored electric energy during discharging at the rated discharging current in Wh. The property value range is 0x00000000 to 0x3B9AC9FF (0 to 999,999,999Wh).

(26) Remaining stored electricity 2

This property indicates the remaining capacity during discharging at the rated discharging current in units of 0.1Ah. The property value range is 0x0000 to 0x7FFE (0 to 3,276.6Ah).

(27) Remaining stored electricity 3

This property indicates the charging rate of the battery in % ((remaining stored electricity)/(full charging capacity) ×100). The property value range is 0x00 to 0x64 (0 to 100).

(28) Deterioration status

This property indicates the deterioration (soundness) status of the battery in %. The property value range is 0x00 to 0x64 (0 to 100).

For example: ((full charging capacity after deterioration)/(initial full charging capacity) ×100).

(29) Battery type

This property indicates the battery type. The property value shall be 0x00 (unknown), 0x01 (lead), 0x02 (nickel-metal hydride), 0x03 (nickel-cadmium), 0x04 (lithium ion), 0x05 (zinc) or 0x06 (rechargeable alkaline). The values from 0x07 to 0xFF are reserved for future use.

(30) Charging amount setting 1

This property specifies the charging electric energy in Wh. (Note that this property does not specify the battery level after charging.) The property value range is 0x00000000 to 0x3B9AC9FF (0 to 999,999,999Wh). The charging status will not affect the value. When charging is completed, the operation mode changes to Standby. For complete charging, this value shall be set equal to or greater than the rated electric energy.

(31) Discharging amount setting 1

This property specifies the discharging electric energy in Wh. (Note that this property does not specify the battery level after discharging.) The property value range is 0x00000000 to 0x3B9AC9FF (0 to 999,999,999Wh). The discharging status will not affect the value. When discharging is completed, the operation mode changes to Standby. For complete discharging, this value shall be set equal to or greater than the rated electric energy.

(32) Charging amount setting 2

This property specifies the charging capacity in units of 0.1Ah. (Note that this property does not specify the battery level after charging.) The property value range is 0x0000 to 0x7FFE (0 to 3,276.6Ah). The charging status will not affect the value. When charging is completed, the operation mode changes to Standby. For complete charging, this value shall be set equal to or greater than the rated capacity.

(33) Discharging amount setting 2

This property specifies the discharging capacity in units of 0.1Ah. (Note that this property does not specify the battery level after discharging.) The property value range is 0x0000 to 0x7FFE (0 to 3,276.6Ah). The discharging status will not affect the value. When discharging is completed, the operation mode changes to Standby. For complete discharging, this value shall be set equal to or greater than the rated capacity.

(34) Charging electric energy setting

This property specifies the charging electric energy in watts. The property value range is 0x00000000 to 0x3B9AC9FF (0 to 999,999,999W).

(35) Discharging electric energy setting

This property specifies the discharging electric energy in watts. The property value range is 0x00000000 to 0x3B9AC9FF (0 to 999,999,999W).

(36) Charging current setting

This property specifies the charging current in units of 0.1A. The property value range is 0x0000 to 0xFFFD (0 to 6,553.3A).

(37) Discharging current setting

This property specifies the discharging current in units of 0.1A. The property value range is 0x0000 to 0xFFFD (0 to 6,553.3A).

(38) Rated voltage (Independent)

This property indicates the rated voltage (catalog value) in volts when the system-interconnected type is independent. The property value range is 0x0000 to 0x7FFE (0 to 32,766V). When this property is not used, the “Rated voltage (independent)” property (EPC = 0xD2) may be used.

3. 3. 18 Requirements for electric vehicle charger/discharger class

Class group code : 0x02
Class code : 0x7E
Instance code : 0x01–0x7F (0x00: All-instance specification code)

Property name	EPC	Contents of property	Data type	Data size	Unit	Access rule	Mandatory	Announcement at status change	Remarks
		Value range (decimal notation)							
Operation status	0x80	This property indicates the ON/OFF status.	unsigned char	1 byte	—	Set		○	
		ON = 0x30, OFF = 0x31				Get			
Dischargeable capacity of vehicle mounted battery 1	0xC0	This property indicates the dischargeable capacity of an electric vehicle mounted battery connected to a charger/discharger in Wh.	unsigned long	4 bytes	Wh	Get	○		Note 1
		0x00000000–0x3B9AC9FF (0–999,999,999Wh)							
Dischargeable capacity of vehicle mounted battery 2	0xC1	This property indicates the dischargeable capacity of an electric vehicle mounted battery connected to a charger/discharger in units of 0.1Ah.	unsigned short	2 bytes	0.1Ah	Get	○		Note 1
		0x0000–0x7FFE (0–3,276.6Ah)							
Remaining dischargeable capacity of vehicle mounted battery 1	0xC2	This property indicates the remaining dischargeable capacity of an electric vehicle mounted battery connected to a charger/discharger in Wh.	unsigned long	4 bytes	Wh	Get	○		Note 2
		0x00000000–0x3B9AC9FF (0–999,999,999Wh)							
Remaining dischargeable capacity of vehicle mounted battery 2	0xC3	This property indicates the remaining dischargeable capacity of an electric vehicle mounted battery connected to a charger/discharger in units of 0.1Ah.	unsigned short	2 bytes	0.1Ah	Get	○		Note 2
		0x0000–0x7FFE (0–3,276.6Ah)							
Remaining dischargeable capacity of vehicle mounted battery 3	0xC4	This property indicates the remaining dischargeable capacity of an electric vehicle mounted battery connected to a charger/discharger in %.	unsigned char	1 byte	%	Get	○		Note 2
		0x00–0x64 (0–100%)							
Rated charge capacity	0xC5	This property indicates the rated charge capacity of an electric vehicle charger/discharger in W.	unsigned long	4 bytes	W	Get	○		
		0x00000000–0x3B9AC9FF (0–999,999,999W)							
Rated discharge capacity	0xC6	This property indicates the rated discharge capacity of an electric vehicle charger/discharger in W.	unsigned long	4 bytes	W	Get	○		
		0x00000000–0x3B9AC9FF (0–999,999,999W)							
Vehicle connection and chargeable/discharge	0xC7	This property indicates whether an electric vehicle charger/discharger can be charged or discharged.	unsigned char	1 byte	—	Get	○	○	

able status		Vehicle not connected = 0x30 Connected to vehicle, Not chargeable, Not dischargeable = 0x40 Connected to vehicle, Chargeable, Not dischargeable = 0x41 Connected to vehicle, Not chargeable, Dischargeable = 0x42 Connected to vehicle, Chargeable, Dischargeable = 0x43							
Minimum/maximum charging electric energy	0xC8	This property indicates the minimum and maximum values of charging electric energy to an electric vehicle charger/discharger in W. 0x00000000–0x3B9AC9FF (0–999,999,999W) Minimum charging electric energy: Maximum charging electric energy	unsigned long × 2	8 bytes	W	Get	○		
Minimum/maximum discharging electric energy	0xC9	This property indicates the minimum and maximum values of discharging electric energy from a vehicle charger/discharger in W. 0x00000000–0x3B9AC9FF (0–999,999,999W) Minimum discharging electric energy: Maximum discharging electric energy	unsigned long × 2	8 bytes	W	Get	○		
Minimum/maximum charging current	0xCA	This property indicates the minimum and maximum values of charging electric energy to an electric vehicle charger/discharger in units of 0.1A. 0x0000–0x7FFE (0–3,276.6A) Minimum charging current: Maximum charging current	unsigned short × 2	4 bytes	0.1A	Get	○		
Minimum/maximum discharging current	0xCB	This property indicates the minimum and maximum values of discharging electric energy from an electric vehicle charger/discharger in units of 0.1A. 0x0000–0x7FFE (0–3,276.6A) Minimum discharging current: Maximum discharging current	unsigned short × 2	4 bytes	0.1A	Get	○		
Used capacity of vehicle mounted battery 1	0xD0	This property indicates the capacity of an electric vehicle mounted battery connected to a charger/discharger in Wh. 0x00000000–0x3B9AC9FF (0–999,999,999Wh)	unsigned long	4 bytes	Wh	Get	○		Note 3
Used capacity of vehicle mounted battery 2	0xD1	This property indicates the capacity of an electric vehicle mounted battery connected to a charger/discharger in units of 0.1Ah. 0x0000–0x7FFE (0–3,276.6Ah)	unsigned short	2 bytes	0.1Ah	Get	○		Note 3
Rated voltage	0xD2	This property indicates the normal rated voltage of an electric vehicle charger/discharger in V. 0x0000–0x7FFE (0–32,766V)	unsigned short	2 bytes	V	Get			
Measured instantaneous charging/discharging electric energy	0xD3	This property indicates the measured instantaneous charging/discharging electric energy in ±W. 0x00000001–0x3B9AC9FF (1–999,999,999W): charging (positive), 0xFFFFFFFF–0xC4653601 (-1–999,999,999W): discharging (negative)	signed long	4 bytes	W	Get			
Measured instantaneous charging/discharging current	0xD4	This property indicates the instantaneous charging/discharging current in units of ±0.1A. 0x0001–0x7FFE (0.1–3,276.6A): charging (positive), 0xFFFF–0x8001 (-0.1– -3,276.7A): discharging (negative)	signed short	2 bytes	0.1A	Get			

Measured instantaneous charging/discharging voltage	0xD5	This property indicates the instantaneous charging/discharging voltage in $\pm V$.	signed short	2 bytes	V	Get			
		0x0001–0x7FFE (1–32,766V): charging (positive), 0xFFFF–0x8001 (-1– -32,767V): discharging (negative)							
Measured integral discharging electric energy	0xD6	This property indicates the integral discharging electric energy in units of 0.001kWh.	unsigned long	4 bytes	0.001 kWh	Get			
		0x00000000–0x3B9AC9FF (0–999,999.999kWh)							
Integral discharging electric energy reset setting	0xD7	This property resets the integral discharging electric energy.	unsigned char	1 byte	—	Set			
		Reset = 0x00							
Measured integral charging electric energy	0xD8	This property indicates the integral charging electric energy in units of 0.001kWh.	unsigned long	4 bytes	0.001 kWh	Get			
		0x00000000–0x3B9AC9FF (0–999,999.999kWh)							
Integral charging electric energy reset setting	0xD9	This property resets the integral charging electricity energy.	unsigned char	1 byte	—	Set			
		Reset = 0x00							
Operation mode setting	0xDA	This property sets the operation mode (Rapid charging /Charging /Discharging /Standby /Test /Other).	unsigned char	1 byte	—	Set /Get	○	○	
		Rapid charging = 0x41, Charging = 0x42, Discharging = 0x43, Standby = 0x44, Test = 0x45, Other = 0x40							
System-interconnected type	0xDB	This property indicates the system interconnection status of an electric vehicle charger/discharger.	unsigned char	1 byte	—	Get			
		System interconnection (reverse power flow acceptable) = 0x00 Independent type = 0x01 System interconnection (reverse power flow not acceptable) = 0x02							
Remaining stored electricity of vehicle mounted battery 1	0xE2	This property indicates the remaining stored capacity of an electric vehicle mounted battery connected to a charger/discharger in Wh.	unsigned long	4 bytes	Wh	Get	○		Note 4
		0x00000000–0x3B9AC9FF (0–999,999.999Wh)							
Remaining stored electricity of vehicle mounted battery 2	0xE3	This property indicates the remaining stored capacity of an electric vehicle mounted battery connected to a charger/discharger in units of 0.1Ah.	unsigned short	2 bytes	0.1Ah	Get	○		Note 4
		0x0000–0x7FFE (0–3,276.6Ah)							
Remaining stored electricity of vehicle mounted battery 3	0xE4	This property indicates the remaining stored capacity of the electric vehicle mounted battery connected to a charger/discharger in %.	unsigned char	1 byte	%	Get	○		Note 4
		0x00–0x64 (0–100%)							
Charging amount setting 1	0xE7	This property specifies the charging electric energy in Wh.	unsigned long	4 bytes	Wh	Set/Get			Note 5
		0x00000000–0x3B9AC9FF (0–999,999.999Wh)							
Charging amount setting 2	0xE9	This property specifies the charging capacity in units of 0.1Ah.	unsigned short	2 bytes	0.1Ah	Set/Get			Note 5
		0x0000–0x7FFE (0–3,276.6Ah)							
Charging electric energy setting	0xEB	This property specifies the charging electric energy in W.	unsigned long	4 bytes	W	Set/Get			
		0x00000000–0x3B9AC9FF (0–999,999.999W)							
Discharging electric energy setting	0xEC	This property specifies the discharging electric energy in W.	unsigned long	4 bytes	W	Set/Get			

		0x00000000-0x3B9AC9FF (0-999,999,999W)							
Charging current setting	0xED	This property specifies the charging current in units of 0.1A.	unsigned short	2 bytes	0.1A	Set/Get			
		0x0000-0xFFFFD (0-6,553.3A)							
Discharging current setting	0xEE	This property specifies the discharging current in units of 0.1A.	unsigned short	2 bytes	0.1A	Set/Get			
		0x0000-0xFFFFD (0-6,553.3A)							
Rated voltage (Independent)	0xEF	Indicates the rated voltage of an independent electric vehicle charger/discharger in V.	unsigned short	2 bytes	V	Get			
		0x0000-0x7FFE (0-32,766V)							

Note: In the “Announcement at status change” column, o denotes mandatory processing when the property is implemented.

Note 1: The installation of “Dischargeable capacity of vehicle mounted battery 1” or “Dischargeable capacity of vehicle mounted battery 2” is mandatory in case of output from an electric vehicle connected to a charger/discharger. Where no response can be returned, “Response impossible” is returned.

Note 2: The installation of “Remaining dischargeable capacity of vehicle mounted battery 1,” “Remaining dischargeable capacity of vehicle mounted battery 2,” or “Remaining dischargeable capacity of vehicle mounted battery 3” is mandatory in case of output from an electric vehicle connected to a charger/discharger. Where no response can be returned, “Response impossible” is returned.

Note 3: The installation of “Used capacity of vehicle mounted battery 1” or “Used capacity of vehicle mounted battery 2” is mandatory in case of output from an electric vehicle connected to a charger/discharger. Where no response can be returned, “Response impossible” is returned.

Note 4: The installation of “Remaining stored electricity of vehicle mounted battery 1,” “Remaining stored electricity of vehicle mounted battery 2,” or “Remaining stored electricity of vehicle mounted battery 3” is mandatory in case of output from an electric vehicle connected to a charger/discharger. Where no response can be returned, “Response impossible” is returned.

Note 5: When “Charging amount setting 1 (or 2)” is used, “Charging amount setting 2 (or 1)” shall not be used.

Electric vehicle charger/discharger includes Electric Vehicle Power System (EVPS) connected to an electric vehicle. Since an electric vehicle connected to an electric vehicle charger/discharger can be changed, the property values of the electric vehicle charger/discharger vary in accordance with the electric vehicle connected to the electric vehicle charger/discharger. When the status (Connected to vehicle, Chargeable/Dischargeable) changes from “Not connected to vehicle” to “Connected to vehicle,” the connected electric vehicle may be different. Therefore, it is preferable to acquire property values again for specifications that are determined by the electric

vehicle and EVPS. For example: Used capacity of vehicle mounted battery 1, Used capacity of vehicle mounted battery 2, Dischargeable capacity of vehicle mounted battery 1, Dischargeable capacity of vehicle mounted battery 2, Remaining dischargeable capacity of vehicle mounted battery 1, Remaining dischargeable capacity of vehicle mounted battery 2, and Remaining dischargeable capacity of vehicle mounted battery 3

AC shall be assumed for currents, voltages, and electric energies handled in this class.

- (1) Operation status (inherited from the property of the device object super class)
This property indicates whether an electric vehicle charger/discharger is ready to accept control commands (ON) or not (OFF). The property value is 0x30 for ON and 0x31 for OFF. The value shall be OFF when no electric vehicle is connected.
- (2) Dischargeable capacity of vehicle mounted battery 1
This property indicates the dischargeable capacity of an electric vehicle mounted battery connected to a charger/discharger in Wh. The property value range is 0x00000000 to 0x3B9AC9FF (0 to 999,999,999Wh).
- (3) Dischargeable capacity of vehicle mounted battery 2
This property indicates the dischargeable capacity of an electric vehicle mounted battery connected to a charger/discharger in units of 0.1Ah. The property value range is 0x0000 to 0x7FFE (0 to 3,276.6Ah).
- (4) Remaining dischargeable capacity of vehicle mounted battery 1
This property indicates the remaining dischargeable capacity of an electric vehicle mounted battery connected to a charger/discharger in Wh. The property value range is 0x00000000 to 0x3B9AC9FF (0 to 999,999,999Wh).
- (5) Remaining dischargeable capacity of vehicle mounted battery 2
This property indicates the remaining dischargeable capacity of an electric vehicle mounted battery connected to a charger/discharger in units of 0.1Ah. The property value range is 0x0000 to 0x7FFE (0 to 3,276.6Ah).
- (6) Remaining dischargeable capacity of vehicle mounted battery 3
This property indicates the remaining dischargeable capacity of an electric vehicle

mounted battery connected to a charger/discharger in %. The property value range is 0x00 to 0x64 (0 to 100%).

(7) Rated charge capacity

This property indicates the rated charge capacity of an electric vehicle charger/discharger in W. The property value range is 0x00000000 to 0x3B9AC9FF (0 to 999,999,999W). When no charging function is supported, the value shall be 0 W.

(8) Rated discharge capacity

This property indicates the rated discharge capacity of an electric vehicle charger/discharger in W. The property value range is 0x00000000 to 0x3B9AC9FF (0 to 999,999,999W). When no discharging function is supported, the value shall be 0 W.

(9) Vehicle connection and chargeable/dischargeable status

This property indicates whether a vehicle is connected to an electric vehicle charger/discharger or not and whether it is chargeable or dischargeable. The property value is 0x30 when no vehicle is connected, 0x40 when a vehicle is connected but not chargeable or dischargeable, 0x41 when the vehicle is chargeable but not dischargeable, 0x42 when the vehicle is not chargeable but dischargeable, and 0x43 when the vehicle is chargeable and dischargeable.

If the vehicle status is unknown until charging or discharging is started, the chargeable/dischargeable status shall be output when a charging or discharging start instruction is given.

(10) Minimum/maximum charging electric energy

This property indicates the minimum and maximum charging electric energies to an electric vehicle charger/discharger in W. Each value range is 0x00000000 to 0x3B9AC9FF (0 to 999,999,999W). The property value represents minimum and maximum in order from the highest-order byte. When the property value of the actual device is higher than the upper limit of the value range, the overflow code 0xFFFFFFFF shall be used. When no charging function is supported, the value shall be 0.

(11) Minimum/maximum discharging electric energy

This property indicates the minimum and maximum discharging electric energies to an electric vehicle charger/discharger in W. Each value range is 0x00000000 to 0x3B9AC9FF (0 to 999,999,999W). The property value represents minimum and maximum in order from the highest-order byte. When the property value of the actual device is higher than the upper limit of the value range, the overflow code 0xFFFFFFFF shall be used. When no discharging function is supported, the value shall be 0.

(12) Minimum/maximum charging current

This property indicates the minimum and maximum charging currents of an electric vehicle charger/discharger in units of 0.1A. Each value range is 0x0000 to 0x7FFE (0 to 3,276.6A). The property value represents minimum and maximum in order from the highest-order byte. When the property value of the actual device is higher than the upper limit of the value range, the overflow code 0xFFFF shall be used. When no charging function is supported, the value shall be 0.

(13) Minimum/maximum discharging current

This property indicates the minimum and maximum discharging currents of an electric vehicle charger/discharger in units of 0.1A. Each value range is 0x0000 to 0x7FFE (0 to 3,276.6A). The property value represents minimum and maximum in order from the highest-order byte. When the property value of the actual device is higher than the upper limit of the value range, the overflow code 0xFFFF shall be used. When no discharging function is supported, the value shall be 0.

(14) Used capacity of vehicle mounted battery 1

This property indicates the capacity of an electric vehicle mounted battery connected to a charger/discharger in Wh. The property value range is 0x00000000 to 0x3B9AC9FF (0 to 999,999,999Wh).

(15) Used capacity of vehicle mounted battery 2

This property indicates the capacity of an electric vehicle mounted battery connected to a charger/discharger in units of 0.1Ah. The property value range is 0x0000 to 0x7FFE (0 to 3,276.6Ah).

(16) Rated voltage

This property indicates the normal rated voltage of an electric vehicle

charger/discharger in V. The property value range is 0x0000 to 0x7FFE (0 to 32,766V).

(17) Measured instantaneous charging/discharging electric energy

This property indicates the instantaneous charging or discharging electric energy of an electric vehicle charger/discharger in W. The property value range is 0x00000001 to 0x3B9AC9FF (1 to 999,999,999W) for charging and 0xFFFFFFFF to 0xC4653601 (-1 to -999,999,999W) for discharging. When the property value of the actual device is higher than the upper limit of the value range, the overflow code 0x7FFFFFFF shall be used. When the property value is lower than the lower limit of the value range, the underflow code 0x80000000 shall be used. The value is 0 for no charging or discharging.

(18) Measured instantaneous charging/discharging current

This property indicates the instantaneous charging or discharging current of an electric vehicle charger/discharger in units of 0.1A. The property value range is 0x0001 to 0x7FFE (0.1 to 3,276.6A) for charging and 0xFFFF to 0x8001 (-0.1 to -3,276.7A) for discharging. When the property value of the actual device is higher than the upper limit of the value range, the overflow code 0x7FFF shall be used. When the property value is lower than the lower limit of the value range, the underflow code 0x8000 shall be used. The value is 0 for no charging or discharging.

(19) Measured instantaneous charging/discharging voltage

This property indicates the instantaneous charging or discharging voltage of an electric vehicle charger/discharger in V. The property value range is 0x0001 to 0x7FFE (1 to 32,766V) for charging and 0xFFFF to 0x8001 (-1 to -32,767V) for discharging. When the property value of the actual device is higher than the upper limit of the value range, the overflow code 0x7FFF shall be used. When the property value is lower than the lower limit of the value range, the underflow code 0x8000 shall be used. The value is 0 for no charging or discharging.

(20) Measured integral discharging electric energy

This property indicates the integral discharging electric energy of an electric vehicle charger/discharger in units of 0.001kWh. The property value range is 0x00000000 to 0x3B9AC9FF (0 to 999,999.999kWh). When the integral electric energy overflows, the property value shall be incremented again from 0x00000000.

(21) Integral discharging electric energy reset setting

This property is set to 0x00 to reset the measured integral discharging electric energy to zero.

(22) Measured integral charging electric energy

This property indicates the integral charging electric energy of an electric vehicle charger/discharger in units of 0.001kWh. The property value range is 0x00000000 to 0x3B9AC9FF (0 to 999,999.999kWh). When the integral electric energy overflows, the property value shall be incremented again from 0x00000000.

(23) Integral charging electric energy reset setting

This property resets the measured integral charging electric energy to zero when 0x00 is set.

(24) Operation mode setting

This property indicates the operation mode of an electric vehicle charger/discharger. The operation mode is Rapid charging (0x41), Charging (0x42), Discharging (0x43), Standby (0x44), Test (0x45), or Other (0x40).

(25) System interconnection status

This property indicates the connection status of the current system and an electric vehicle charger/discharger (system interconnection status).

System-interconnected (reverse power flow acceptable) = 0x00, Independent = 0x01,
System-interconnected (reverse power flow not acceptable) = 0x02

(26) Remaining stored electricity of vehicle mounted battery 1

This property indicates the remaining stored capacity of an electric vehicle mounted battery connected to a charger/discharger in Wh. The property value range is 0x00000000 to 0x3B9AC9FF (0 to 999,999,999Wh).

(27) Remaining stored electricity of vehicle mounted battery 2

This property indicates the remaining stored capacity of an electric vehicle mounted battery connected to a charger/discharger in units of 0.1Ah. The property value range is 0x0000 to 0x7FFE (0 to 3,276.6Ah).

(28) Remaining stored electricity of vehicle mounted battery 3

This property indicates the remaining stored capacity (SOC: State of Charge) of an electric vehicle mounted battery connected to a charger/discharger in %. The property value range is 0x00 to 0x64 (0 to 100%).

(29) Charging amount setting 1

This property specifies the charging electric energy in Wh. The property value range is 0x00000000 to 0x3B9AC9FF (0 to 999,999,999Wh). The value is 0 for no charging.

(30) Charging amount setting 2

This property specifies the charging capacity in units of 0.1Ah. The property value range is 0x0000 to 0x7FFE (0 to 3,276.6Ah). The value is 0 for no charging.

(31) Charging electric energy setting

This property specifies the charging electric energy in W. The property value range is 0x00000000 to 0x3B9AC9FF (0 to 999,999,999W).

(32) Discharging electric energy setting

This property specifies the discharging electric energy in the system-interconnected status in W. The property value range is 0x00000000 to 0x3B9AC9FF (0 to 999,999,999W). The value is 0 for no discharging. In the independent status, "Response impossible" is returned.

(33) Charging current setting

This property specifies the charging current in units of 0.1A. The property value range is 0x0000 to 0xFFFD (0 to 6,553.3A). The value is 0 for no charging.

(34) Discharging current setting

This property specifies the discharging current in the system-interconnected status in units of 0.1A. The property value range is 0x0000 to 0xFFFD (0 to 6,553.3A). The value is 0 for no discharging. In the independent status, "Response impossible" is returned.

(35) Rated voltage (Independent)

This property indicates the rated voltage (catalog value) in V when the system

interconnection status is “Independent.” The property value range is 0x0000 to 0x7FFE (0 to 32,766V). When this property is not used, the rated voltage (EPC = 0xD2) may be used as the value as the independent status.

3. 3. 19 Requirements for engine cogeneration class

Class group code : 0x02
Class code : 0x7F
Instance code : 0x01 to 0x7F (0x00: All instance specification code)

Property name	EPC	Contents of property	Data type	Data size	Unit	Access rule	Mandatory	Announcement at status change	Remark
		Value range (decimal notation)							
Operation status	0x80	This property indicates the ON/OFF status.	unsigned char	1 byte	-	Set	○	○	
		ON=0x30, OFF=0x31				Get			
Measured temperature of water in water heater	0xC1	This property indicates the current temperature of the water in the water heater in °C.	unsigned char	1 byte	°C	Get			
		0x00-0x64 (0-100°C)							
Rated power generation output	0xC2	This property indicates the rated power generation output in watts.	unsigned short	2 bytes	W	Get			
		0x0000-0xFFFD (0-65,533W)							
Heating value of hot water storage tank	0xC3	This property indicates the heating value of the hot water storage tank in MJ.	unsigned short	2 bytes	MJ	Get			
		0x0000-0xFFFD (0-65,533MJ)							
Measured instantaneous power generation output	0xC4	This property indicates the instantaneous power generation output in watts.	unsigned short	2 bytes	W	Get	○		
		0x0000-0xFFFD (0-65,533W)							
Measured cumulative power generation output	0xC5	This property indicates the cumulative power generation output in increments of 0.001kWh.	unsigned long	4 bytes	0.001kWh	Get	○		
		0x00000000-0x3B9AC9FF (0-999,999.999kWh)							
Cumulative power generation output reset setting	0xC6	Resets the cumulative power generation output by writing 0x00.	unsigned char	1 byte	-	Set			
		Reset=0x00							
Measured instantaneous gas consumption	0xC7	This property indicates the instantaneous gas consumption in increments of 0.001m ³ /h.	unsigned short	2 bytes	0.001m ³ /h	Get			
		0x0000-0xFFFD (0-65.533m ³ /h)							
Measured cumulative gas consumption	0xC8	This property indicates the cumulative gas consumption in increments of 0.001m ³ .	unsigned long	4 bytes	0.001m ³	Get			
		0x00000000-0x3B9AC9FF (0-999,999.999m ³)							
Cumulative gas consumption reset setting	0xC9	Resets the cumulative gas consumption by writing 0x00.	unsigned char	1 byte	-	Set			
		Reset=0x00							

Power generation setting	0xCA	This property indicates the setting of start or stop of power generation.	unsigned char	1 byte	—	Set/Get			
		Power generation ON=0x41, Power generation OFF=0x42							
Power generation status	0xCB	This property indicates power generation status.	unsigned char	1 byte	—	Get			
		generating =0x41, stopped=0x42, idling=0x45							
Measured in-house instantaneous power consumption	0xCC	This property indicates the measured in-house instantaneous power consumption in watts.	unsigned short	2 bytes	W	Get			
		0x0000-0xFFFFD (0-65.533W)							
Measured in-house cumulative power consumption	0xCD	This property indicates the measured in-house cumulative power consumption in0.001kWh.	unsigned long	4 bytes	0.001kWh	Get			
		0x00000000-0x3B9AC9FF (0-999,999.999kWh)							
In-house cumulative power consumption reset	0xCE	This property is set to 0x00 to reset the in-house cumulative power consumption.	unsigned char	1 byte		Set			
		Reset=0x00							
System interconnected type	0xD0	This property indicates the system interconnected type.	unsigned char	1 byte	—	Get			
		System-interconnected type (reverse power flow acceptable)=0x00, Independent type=0x01, System-interconnected type(reverse power flow not acceptable)=0x02							
Measured remaining hot water amount	0xE1	This property indicates the measured amount of the remaining hot water in liters.	unsigned short	2 bytes	liter	Get			
		0x0000-0xFFFFD (0-65,533 liters)							
Tank capacity	0xE2	This property indicates the tank capacity in liters.	unsigned short	2 bytes	liter	Get			
		0x0000-0xFFFFD (0-65,533 liters)							

Note: In the “Announcement at status change” column, o denotes mandatory processing when the property is implemented.

(1) Operation status (a property inherited from the device object super class)

This property indicates whether the functions specific to this class are operating (ON) or not (OFF). In the case of a node in which this class is implemented and the functions specific to this class start operating upon startup of the node, this property may be implemented with the value fixed at 0x30 (operation status ON).

(2) Measured hot water temperature of water heater

This property indicates the current hot water temperature in the hot water storage tank in °C. The property value range is 0x00 to 0x64 (0 to 100°C).

(3) Rated power generation output

This property indicates the rated power generation output in watts. The property value range is 0x0000 to 0xFFFFD. When the property value of the actual device is higher than the upper bound of the value range, 0xFFFF (overflow code) shall be used. When the property value of the actual device is lower than the lower bound of the value range, 0xFFFE (underflow code) shall be used.

(4) Heating value of hot water storage tank

This property indicates the heating value of a hot water storage tank in MJ. The property value range is 0x0000 to 0xFFFFD. When the property value of the actual device is higher than the upper bound of the value range, 0xFFFF (overflow code) shall be used. When the property value of the actual device is lower than the lower bound of the value range, 0xFFFE (underflow code) shall be used.

(5) Measured instantaneous power generation output

This property indicates the instantaneous power generation output in watts. The property value range is 0x0000 to 0xFFFFD. When the property value of the actual device is higher than the upper bound of the value range, 0xFFFF (overflow code) shall be used. When the property value of the actual device is lower than the lower bound of the value range, 0xFFFE (underflow code) shall be used.

(6) Measured cumulative power generation output

This property indicates the cumulative power generation output in units of 0.001kWh. The property value range is 0x00000000 to 0x3B9AC9FF (0 to 999,999.999 kWh). In the event of a cumulative power generation output overflow, the counting of the cumulative power generation output shall be restarted from 0x00000000.

(7) Cumulative power generation output reset setting

Resets the cumulative power generation output to zero by setting 0x00.

(8) Measured instantaneous gas consumption

This property indicates the instantaneous gas consumption in units of 0.001m³/h. The property value range is 0x0000 to 0xFFFFD. (0 to 65.533 m³/h) When the property value of the actual device is higher than the upper bound of the value range, 0xFFFF (overflow code) shall be used. When the property value of the actual device

is lower than the lower bound of the value range, 0xFFFFE (underflow code) shall be used.

(9) Measured cumulative gas consumption

This property indicates the cumulative gas consumption in units of 0.001m³. The property value range is 0x00000000 to 0x3B9AC9FF (0 to 999,999.999 m³). In the event of a cumulative gas consumption overflow, the counting of the cumulative gas consumption shall be restarted from 0x00000000.

(10) Cumulative gas consumption reset setting

Resets the cumulative gas consumption to zero by setting 0x00.

(11) Power generation setting

This property indicates the setting of power generation by the engine cogeneration. The property value for power generation ON is 0x41, and the property value for power generation OFF is 0x42.

(12) Power generation status

This property indicates the power generation status of the engine cogeneration. The property value for generating is 0x41, the property value for stopped is 0x42 and the property value for idling is 0x45.

(13) Measured in-house instantaneous power consumption

This property indicates the in-house instantaneous power consumption in watts. The property value range is 0x0000 to 0xFFFFD. When the property value of the actual device is higher than the value range of this property, the overflow code 0xFFFFF shall be used. When the property value is lower than the value range of this property, the underflow code 0xFFFFE shall be used.

In-house instantaneous power consumption is the sum of power where an anti-reverse power flow CT is installed and the power output.

(14) Measured in-house cumulative power consumption

This property indicates the in-house cumulative power consumption in units of 0.001kWh. The property value range is 0x00000000 to 0x3B9AC9FF (0 to 999,999.999kWh) and shall increment again from 0x00000000 in case of a cumulative power consumption overflow.

In-house cumulative power consumption is the sum of power where an anti-reverse power flow CT is installed and power output.

(15) In-house cumulative power consumption reset

This property is set to 0x00 to reset the in-house cumulative power consumption to zero.

In-house cumulative power consumption is the sum of power where an anti-reverse power flow CT is installed and the power output.

(16) System-interconnected type

This property indicates the status of interconnection with the current system (system-interconnected type).

System interconnection (reverse power flow acceptable) = 0x00, Independent type = 0x01, System interconnection (reverse power flow not acceptable) = 0x02.

(17) Measured remaining hot water amount

This property indicates the amount of hot water remaining in the tank in liters. The property value range is 0x0000 to 0xFFFFD (from 0 to 65,533 liters). When the property value of the actual device is higher than the upper bound of the value range, 0xFFFF (overflow code) shall be used. When the property value of the actual device is lower than the lower bound of the value range, 0xFFFFE (underflow code) shall be used.

(18) Tank capacity

This property indicates the tank capacity in liters. The property value range is 0x0000 to 0xFFFFD (0 to 65,533 liters). When the property value of the actual device is higher than the upper bound of the value range, 0xFFFF (overflow code) shall be used. When the property value of the actual device is lower than the lower bound of the value range, 0xFFFFE (underflow code) shall be used.

3. 3. 20 Requirements for watt-hour meter class

Class group code : 0x02

Class code : 0x80

Instance code : 0x01–0x7F (0x00: All-instance specification code)

Property name	EPC	Contents of property	Data type	Data size	Unit	Access rule	Mandatory	Announcement at status change	Remark
		Value range (decimal notation)							
Operation status	0x80	This property indicates the ON/OFF status.	unsigned char	1 byte	—	Set		○	
		ON=0x30, OFF=0x31				Get			
Integral electric energy measurement value	0xE0	This property indicates integral electric energy in decimal (8 digits).	unsigned long	4 bytes	0.1 or 0.01 kWh	Get	○		
		0x00000000–0x05F5E0FF (0–99,999,999)							
Integral electric energy unit	0xE2	This property indicates number of decimal places of integral electric energy (0xE0).	unsigned char	1 byte	—	Get	○		
		0x01 : 0.1kWh 0x02 : 0.01kWh							
Integral electric energy measurement log 1	0xE3	This property indicates integral electric energy (8 digits) measurement result log in 30-minute segments for past 24 hours.	unsigned long ×48	192 bytes	0.1 or 0.01 kWh	Get			
		0x00000000–0x05F5E0FF (0–99,999,999)							
Integral electric energy measurement log 2	0xE4	This property indicates integral electric energy (8 digits) measurement result log for past 24 hours as one-day data in 30-minute segments for the past 45 days.	unsigned long ×48 ×45	192 bytes ×45	0.1 or 0.01 kWh	GetM			
		0x00000000–0x05F5E0FF (0–99,999,999)							

Note: In the “Announcement at status change” column, ○ denotes mandatory processing when the property is implemented.

(1) Operation status (inherited from the device object super class property)

This property indicates whether the function native to this class is operating or not (ON/OFF). In the node mounting this class, if the function of this class is started concurrently with the start of node operation, this property may be implemented at a fixed value of 0x30 (Operation status ON).

(2) Integral electric energy measurement value

This property indicates the cumulative usage of electricity (up to 8 digits in decimal notation). The unit of cumulative usage of electricity is given by the “Integral electric energy unit” property (EPC = 0xE2). The unit shall be 0.1 kWh when the value of the “Integral electric energy unit” property is 0x01 and 0.01 kWh when the

value of the “Integral electric energy unit” property is 0x02. The property value range shall be 0x00000000 to 0x05F5E0FF (0 to 99,999,999). When the property value exceeds the upper limit of the property value range, the counter will be reset to 0x00000000 and counting will start again from 0x00000000.

(3) Integral electric energy unit

This property indicates the number of decimal places of the integral electric energy (EPC = 0xE0). When the property value is 0x01, “Integral electric energy” (EPC = 0xE0) shall take the unit of 0.1 kWh. When the property is 0x02, “Integral electric energy” (EPC = 0xE0) shall take the unit of 0.01 kWh.

(4) Integral electric energy measurement log 1

This property indicates the integral electric energy (EPC = 0xE0) measurement result log for the past 24 hours in 30-minute segments. The unit is indicated by the property value of “Integral electric energy unit” (EPC = 0xE2). When “Integral electric energy unit” (EPC = 0xE2) is 0x01, the unit shall be 0.1 kWh. When “Integral electric energy unit” (EPC = 0xE2) is 0x02, the unit shall be 0.01 kWh. The measured value of integral electric energy for each 30 minutes shall be based on the time to be set in the property name “Time setting” (EPC-0x97). The measured value in units of 8 digits at every 0 minutes and 30 minutes shall be the data of 0x00000000 to 0x05F5E0FF (0 to 99,999,999). The property value shall begin with the high-order byte in time series. For time data that is not yet measured for the measurement log, 0xFFFFFFFFE shall be used.

(5) Integral electric energy measurement log 2

This property indicates the historical cumulative usage data for the past 45 days in the form of an array with 45 elements, each of which contains the historical cumulative usage data for each day. Each array element has forty-eight 4-byte sub-elements, each of which contains the cumulative usage measurement (i.e. the value of the “integral electric energy” property (EPC = 0xE0)) for each of the forty-eight 30-minute periods of the day (The first 30-minute period of the day starts at 0:00 as indicated by the “current time setting” property (EPC = 0x97) and the last 30-minute period of the day ends at 23:30 as indicated by the “current time setting” property). The unit shall be 0.1 kWh when the value of the “Integral electric energy unit” property (EPC = 0xE2) is 0x01 and 0.01 kWh when the value of the “Integral electric energy unit” property is 0x02. The value range for each sub-element shall be 0x000000 to 0x05F5E0FF (0 to 99,999,999). The historical cumulative usage data shall be arranged in chronological order on both the array element and sub-element levels. If there is any 30-minute period for which measurement does not exist, 0xFFFFFFFFE shall be used as the value for that period.

3. 3. 21 Requirements for water flowmeter class

Class group code : 0x02

Class code : 0x81

Instance code : 0x01–0x7F (0x00: All-instance specification code)

Property name	EPC	Contents of property	Data type	Data size	Unit	Access rule	Mandatory	Announcement at status change	Remark
		Value range (decimal notation)							
Operation status	0x80	This property indicates the ON/OFF status.	unsigned char	1 byte	—	Set		○	
		ON=0x30, OFF=0x31				Get			
Flowing water classification	0xD0	This property indicates the water flowmeter type.	unsigned char	1 byte	—	Set/Get			
		0x30 : running water 0x31 : recycled water 0x32 : warm water 0x33 : other water							
Owner classification	0xD1	This property indicates the owner of the meter in the form of owner classification.	unsigned char	1 byte	—	Set/Get			
		0x30 : Not specified 0x31 : Public waterworks company 0x32 : Private sector company 0x33 : Individual							
Measured cumulative amount of flowing water	0xE0	This property indicates the cumulative amount (consumption) of flowing water using a 9-digit number.	unsigned long	4 bytes	m ³	Get	○		
		0x00000000–0x3B9AC9FF (0–999,999,999)							
Unit for measured cumulative amounts of flowing water	0xE1	This property indicates the unit (multiplying factor) for the measured cumulative amount of flowing water and the historical data of measured cumulative amounts of flowing water.	unsigned char	1 byte	—	Get	○		
		0x00: 1m ³ 0x01: 0.1m ³ 0x02: 0.01m ³ 0x03: 0.001m ³ 0x04: 0.0001m ³ (Initial value) 0x05: 0.00001m ³ 0x06: 0.000001m ³							
Historical data of measured cumulative amounts of flowing water	0xE2	This property indicates the historical data of measured cumulative amounts (consumptions) of running water, which consists of 48 pieces of half-hourly data for the preceding 24 hours.	unsigned long ×48	192 bytes	0.001 m ³	Get			
		0x00000000–0x3B9AC9FF (0–999,999,999m ³)							

Detection of abnormal value in metering data	0xE3	This property indicates whether the meter has detected an abnormal value in the metering data.	unsigned char	1 byte	—	Get		○	
		Abnormal value detected: 0x41 No abnormal value detected: 0x42							
Security data information	0xE4	Provides security information about the abnormal states detected by the meter in the form of security data that identifies the abnormal states by means of bit assignment.	unsigned long	4bytes	—	Get			
		0-0xFFFFFFFF							
ID number setting	0xE5	This property indicates the ID number of the meter.	unsigned char	6 bytes		Set/Get			
		The ID number is specified using ASCII code. (Initial value : "000000")							
Verification expiration information	0xE6	This property indicates the month and year in which the verification of the meter will expire.	unsigned char	6 bytes		Set/Get			
		The month and year are specified using ASCII code. <u>XXXX XX</u> Year Month							

Note: In the "Announcement at status change" column, ○ denotes mandatory processing when the property is implemented.

- (1) Operation status (a property inherited from the device object super class)
This property indicates whether the functions specific to this class are operating (ON) or not (OFF). In the case of a node in which this class is implemented and the functions specific to this class start operating upon startup of the node, this property may be implemented with the value fixed at 0x30 (operation status ON).
- (2) Water flowmeter classification
This property indicates the type of the flowing water being metered in the form of meter classification.
- (3) Owner classification
This property indicates the owner of the water flowmeter in the form of owner classification.
- (4) Measured cumulative amount of flowing water
This property indicates the measured cumulative amount of running water using a 9-digit decimal notation number. The unit is indicated by the "Unit for measured cumulative amount of running water" property (EPC=0xE1). When the value of the "Unit for measured cumulative amounts of running water" property (which indicates the multiplying factor for measured cumulative amounts of running water)

is 0x00, 0x01, 0x02, 0x03, 0x04, 0x05 or 0x06, the unit shall be 1m^3 , 0.1m^3 , 0.01m^3 , 0.001m^3 , 0.0001m^3 , 0.00001m^3 or 0.000001m^3 , respectively. The property value range is from 0x00000000 to 3B9AC9FF (from 0 to 99,999,999). In the event of a measured cumulative running water amount overflow, the counting of the measured cumulative amount of running water shall be restarted from 0x00000000.

Example:

If the value of the “Measured cumulative amount of flowing water” property indicates that the measured cumulative amount of running water is 123456789 and the value of the “Unit for measured cumulative amount of flowing water” property is 0x04, the actual measured cumulative amount would be:

$$123456789 \times 0.0001\text{m}^3 = 12345.6789\text{m}^3 \text{ (actual measured cumulative amount)}$$

(5) Unit for measured cumulative amounts of flowing water

This property indicates the unit for measured cumulative amounts of flowing water.

Property value	Multiplying factor for measured cumulative amounts of flowing water
0x00	1m^3
0x01	0.1m^3
0x02	0.01m^3
0x03	0.001m^3
0x04	0.0001m^3
0x05	0.00001m^3
0x06	0.000001m^3

(6) Historical data of measured cumulative amounts of running water

This property indicates the historical data of measured cumulative amounts of running water (unit = 0.001m^3), which consists of 48 pieces of half-hourly data for the preceding 24 hours. The half-hourly cumulative running water amount measurements shall be measurements that have been taken, in increments of 0.001m^3 , every hour and every half-hour by reference to the time indicated by the “Current time setting” property (EPC=0x97). The measurements shall be stored in the order they have been taken, with the oldest and newest measurements stored in the highest-order and lowest-order bytes, respectively. The property value range is from 0x00000000 to 0x3B9AC9FF (from 0 to 999,999.999 m^3). For non-measured time data in the historical data, 0xFFFFFFFF shall be set.

(7) Detection of abnormal value in metering data

This property indicates whether the meter has detected an abnormal value in the metering data. The property value shall be 0x41 when an abnormal value has been detected and 0x42 when no abnormal value has been detected.

(8) Security data information

Provides security information about the abnormal states detected by the meter in the form of security data that identifies the abnormal states by means of bit assignment.

(9) ID number setting

This property indicates the ID number of the meter. The ID number shall be a 6-digit code comprised of 6 one-byte alphanumeric characters.

ID numbers are used when there are two or more meters.

(10) Verification expiration information

When the meter is one that has been verified by a verifying organization, this property indicates the month and year in which the verification of the meter will expire.

3. 3. 22 Requirements for gas meter class

Class group code : 0x02

Class code : 0x82

Instance code : 0x01–0x7F (0x00: All-instance specification code)

Property name	EPC	Contents of property	Data type	Data size	Unit	Access rule	Mandatory	Announcement at status change	Remark
		Value range (decimal notation)							
Operation status	0x80	This property indicates the ON/OFF status.	unsigned char	1 byte	—	Set		○	
		ON=0x30, OFF=0x31				Get			
Integral gas consumption measurement value	0xE0	This property indicates integral gas consumption in units of 0.001 m ³ .	unsigned long	4 bytes	0.001m ³	Get	○		
		0x00000000–0x3B9AC9FF (0–999999,999m ³)							
Integral gas consumption measurement log	0xE2	This property indicates integral gas consumption measurement result log for past 24 hours as data in 30-minute segments.	unsigned long × 48	192 bytes	0.001m ³	Get			
		0x00000000–0x3B9AC9FF (0–999999,999m ³)							

Note: In the “Announcement at status change” column, ○ denotes mandatory processing when the property is implemented.

(1) Operation status (inherited from the device object super class property)

This property indicates whether the function native to this class is operating or not (ON/OFF). In the node mounting this class, if the function of this class is started concurrently with the start of node operation, this property may be implemented at a fixed value of 0x30 (Operation status ON).

(2) Integral gas consumption measurement value

This property indicates the integral gas consumption in units of 0.001 m³. The property value range shall be 0x00000000 to 0x3B9AC9FF (0 to 999,999,999 m³). When the integral gas consumption value overflows, the property shall be incremented again from 0x00000000.

(3) Integral gas consumption measurement log

This property indicates the Integral gas consumption (EPC = 0xE0) measurement result log for the past 24 hours as the data in 30-minute segments. The measured value of integral gas consumption for each 30 minutes shall be based on the time to be set in the property name “Current time setting” (EPC-0x97). The measured value in units of 0.1 m³ at every 0 minutes and 30 minutes shall be the data of 0x00000000 to 0x3B9AC9FF (0 to 999,999,999 m³). The property value shall begin with the

high-order byte in time series. For non-measured time data in the historical data, 0xFFFFFFFF shall be set.

3. 3. 23 Requirements for LP gas meter class

Class group code : 0x02

Class code : 0x83

Instance code : 0x01–0x7F (0x00: All-instance specification code)

Property name	EPC	Contents of property	Data type	Data size	Unit	Access rule	Mandatory	Announcement at status change	Remark
		Value range (decimal notation)							
Operation status	0x80	This property indicates the ON/OFF status.	unsigned char	1 byte	—	Set		○	
		ON=0x30, OFF=0x31							
Integral gas consumption of metering data 1	0xE0	This property indicates integral gas consumption in units of 0.0001 m ³ .	unsigned long	4 bytes	0.0001 m ³	Get	○		
		0–0x005F5E0FF (0–9999,999 m ³)							
Integral gas consumption of metering data 2	0xE1	This property indicates integral gas consumption in units of 0.001 m ³ .	unsigned long	4 bytes	0.001 m ³	Get	○		
		0–0x005F5E0FF (0–9999,999 m ³)							
Error detection status of metering data	0xE2	This property indicates status where meter detected metering data error.	unsigned char	1 byte	–	Get		○	
		Error detection status found = 0x41 Error detection status not found = 0x42							
Security data 1	0xE3	This property indicates security data to define security information on meter operation by bit allocation.	unsigned long	4 bytes	–	Get			
		0–0xFFFFFFFF							
Security data 2	0xE4	This property indicates security data to define security information on meter operation by bit allocation.	unsigned long	4 bytes	–	Get			
		0–0xFFFFFFFF							
Center valve shut-off status	0xE5	This property indicates status where gas shut-off valve of meter has been shut off by center.	unsigned char	1 byte	–	Get		○	
		Center valve shut-off status found = 0x41 Center valve shut-off status not found = 0x42							
Center valve shut-off recovery permission setting status	0xE6	This property indicates status where gas shut-off valve of meter has been shut off by center.	unsigned char	1 byte	–	Get			
		Center valve shut-off reset enable = 0x41 Center valve shut-off reset not enable = 0x42							
Emergency valve shut-off status	0xE7	This property indicates status where gas shut-off valve of meter has been shut off.	unsigned char	1 byte	–	Get			
		Emergency valve shut-off status found = 0x41 Emergency valve shut-off status not found = 0x42							

Shut-off valve open/close status	0xE8	This property indicates open/close status of shut-off valve.	unsigned char	1 byte	-	Get			
		Shut-off valve open status = 0x41 Shut-off valve close status = 0x42							
Residual volume control warning	0xE9	This property indicates status as warning where residual volume is very small.	unsigned char	1 byte	-	Get		○	
		Residual volume control warning level 1 0x31 Residual volume control warning level 2 0x32 Residual volume control warning level 3 0x33 No residual volume control warning 0x42							
Set value of residual volume control warning level 1	0xEA	Sets "Small residual volume detection level 1".	unsigned char × 3	3 bytes	liter	Set/Get			
		0-0xFFFFFFFF (0-16,777,215)							
Set value of residual volume control warning level 2	0xEB	Sets "Small residual volume detection level 2".	unsigned char × 3	3 bytes	liter	Set/Get			
		0-0xFFFFFFFF (0-16,777,215)							
Set value of residual volume control warning level 3	0xEC	Sets "Small residual volume detection level 3".	unsigned char × 3	3 bytes	liter	Set/Get			
		0-0xFFFFFFFF (0-16,777,215)							
Slight leak timer value (gas flow rate continuation)	0xED	This property indicates number of days on which gas flow rate is continued.	unsigned char	1 byte	Day	Get			
		0-0xFD (0-253) (0 to 253 days)							
Slight leak timer value (without pressure increase)	0xEE	This property indicates number of days on which gas leak monitoring is performed without gas pressure increase.	unsigned char	1 byte	Day	Get			
		0-0xFD (0-253) (0 to 253 days)							
Shut-off reason log	0xEF	Defines log of reasons for gas shut-off by shut-off valve in 1 byte each with bits assigned. Shows the last three logs. Log 3: log 2: log 1	unsigned char × 3	3 bytes	-	Get			
		0xFF: 0xFF: 0xFF							
Maximum value of supply pressure data	0xD0	This property indicates maximum value of supply pressure data in units of 0.01 kPa.	unsigned short	2 bytes	0.01 kPa	Get			
		0x0000-0xFFFFD (0-655.33) (0-655.33 kPa)							
Minimum value of supply pressure data	0xD1	This property indicates minimum value of supply pressure data in units of 0.01 kPa.	unsigned short	2 bytes	0.01 kPa	Get			
		0x0000-0xFFFFD (0-655.33) (0-655.33 kPa)							
Current value of supply pressure data	0xD2	This property indicates current value of supply pressure data in units of 0.01 kPa.	unsigned short	2 bytes	0.01 kPa	Get			
		0x0000-0xFFFFD (0-655.33) (0-655.33 kPa)							
Maximum value of block pressure data	0xD3	This property indicates minimum value of supply pressure data in units of 0.01 kPa.	unsigned short	2 bytes	0.01 kPa	Get			
		0x0000-0xFFFFD (0-655.33) (0-655.33 kPa)							
Minimum value of block pressure	0xD4	This property indicates minimum value of supply pressure data in units of 0.01 kPa.	unsigned short	2 bytes	0.01 kPa	Get			

data		0x0000–0xFFFFD (0–655.33) (0–655.33 kPa)							
Current value of block pressure data	0xD5	This property indicates current value of block pressure data in units of 0.01 kPa.	unsigned short	2 bytes	0.01 kPa	Get			
		0x0000–0xFFFFD (0–655.33) (0–655.33 kPa)							
Number of block pressure/supply pressure error days: times	0xD6	This property indicates number of days on which block pressure/supply pressure errors occurred in 1 byte each.	unsigned char × 4	4 bytes	–	Get			
		Number of block pressure error days: Number of supply pressure error days: Number of block pressure error times: Number of supply pressure error times							
Test call setting	0xD7	Performs test call operation setup.	unsigned char	1 byte	–	Set/Get			
		Test call operation ON 0x41 Test call operation OFF 0x42							

Note: In the “Announcement at status change” column, ○ denotes mandatory processing when the property is implemented.

- (1) Operation status (inherited from the device object super class property)
 This property indicates whether the LP gas meter is operating or not (ON/OFF). In the node mounting this class, if the function of the LP gas meter is started concurrently with the start of node operation, this property may be implemented at a fixed value of 0x30 (Operation status ON).
- (2) Integral gas consumption of metering data 1
 This property indicates the integral gas consumption in units of 0.0001 m³. The property value range shall be 0x00000000 to 0x005F5E0FF (0 to 9999,9999 m³). When the integral gas consumption overflows, the property value shall be incremented again from 0x00000000. Either “Integral gas consumption of metering data 1” (EPC = 0xE0) or “Integral gas consumption of metering data 2” (EPC = 0xE1) must be implemented.
- (3) Integral gas consumption of metering data 2
 This property indicates the integral gas consumption in units of 0.001 m³. The property value range shall be 0x00000000 to 0x005F5E0FF (0 to 99999,999 m³). When the integral gas consumption overflows, the property value shall be incremented again from 0x00000000. Either “Integral gas consumption of metering data 1” (EPC = 0xE0) or “Integral gas consumption of metering data 2” (EPC = 0xE1) must be implemented.
- (4) Error detection status of metering data
 This property indicates that a metering data error was detected. The property shall be 0x41 for “Error detection status found” and 0x42 for “Error detection status not

found”.

(5) Security data 1

This property indicates the security data to define the security information on meter error detection by bit allocation.

(6) Security data 2

This property indicates the security data to define the security information on meter error detection by bit allocation.

(7) Center valve shut-off status

This property indicates a status where the gas shut-off valve of the meter is shut off by the center. In the status of “Center valve shut-off request found”, no request for opening the shut-off valve will be accepted until a reset permission is given from the center.

(8) Center valve shut-off recovery permission setting status

Specifies whether or not to enable the function for recovering from the shut-off state of the meter's gas shut-off valve. The value for enabling the center valve shut-off recovery function shall be 0x41. The value for disabling the center valve shut-off recovery function shall be 0x40.

(9) Emergency valve shut-off status

This property indicates that the meter's gas shut-off valve is closed because of an emergency. The value 0x41 shall indicate that the emergency valve shut-off status is found. The value 0x42 shall indicate that the emergency valve shut-off status is not found.

(10) Shut-off valve open/close status

This property indicates whether the shut-off valve is open or closed. The value 0x41 shall indicate that the shut-off valve is open. The value 0x42 shall indicate that the shut-off valve is closed.

(11) Residual volume control warning

Issues a warning to indicate that the residual volume is very small. The value 0x31 indicates residual volume control warning level 1. The value 0x32 indicates residual volume control warning level 2. The value 0x33 indicates residual volume control warning level 3. The value 0x42 indicates that no residual volume control warning is issued. When the residual volume decreases below a residual volume control

warning level setting (the property value for the set value of residual volume control warning level 1, set value of residual volume control warning level 2, or set value of residual volume control warning level 3), the associated property value shall be taken as stated above. The residual volumes indicated by the three warning levels shall be, in decreasing order, the set value of residual volume control warning level 1, set value of residual volume control warning level 2, and set value of residual volume control warning level 3.

(12) Set value of residual volume control warning level 1

Sets the residual gas volume that changes the value of the residual volume control warning property (0xE9) to residual volume control warning level 1 (0x31). The property value range shall be 0 to 0xFFFFFFFF (0 to 16,777,215 liters).

(13) Set value of residual volume control warning level 2

Sets the residual gas volume that changes the value of the residual volume control warning property (0xE9) to residual volume control warning level 2 (0x32). The property value range shall be 0 to 0xFFFFFFFF (0 to 16,777,215 liters).

(14) Set value of residual volume control warning level 3

Sets the residual gas volume that changes the value of the residual volume control warning property (0xE9) to residual volume control warning level 3 (0x33). The property value range shall be 0 to 0xFFFFFFFF (0 to 16,777,215 liters).

(15) Slight leak timer value (gas flow rate continuation)

This property indicates the number of days for which gas has flowed continuously. The property value range shall be 0 to 0xFD (0 to 253 days).

(16) Slight leak timer value (without pressure increase)

This property indicates the number of days for which gas leak monitoring has been conducted with no gas pressure increase detected. The property value range shall be 0 to 0xFD (0 to 253 days).

(17) Shut-off reason log

Defines the log of reasons for gas shut-off by the shut-off valve in 1 byte each, with assigned bits. Shows the last three logs. The property value shall be structured so as to sequentially indicate Log 3, Log 2, and Log 1, beginning with the high-order byte. Log 1 shall be the last log. Log 2 shall be the log obtained immediately before Log 1. Log 3 shall be the log obtained immediately before Log 2.

- (18) Maximum value of supply pressure data
This property indicates the maximum value of supply pressure data in units of 0.01 kPa. The property value range shall be 0x0000 to 0xFFFFD (0 to 655.33 kPa).
- (19) Minimum value of supply pressure data
This property indicates the minimum value of supply pressure data in units of 0.01 kPa. The property value range shall be 0x0000 to 0xFFFFD (0 to 655.33 kPa).
- (20) Current value of supply pressure data
This property indicates the current value of supply pressure data in units of 0.01 kPa. The property value range shall be 0x0000 to 0xFFFFD (0 to 655.33 kPa).
- (21) Maximum value of block pressure data
This property indicates the maximum value of block pressure data in units of 0.01 kPa. The property value range shall be 0x0000 to 0xFFFFD (0 to 655.33 kPa).
- (22) Minimum value of block pressure data
This property indicates the minimum value of block pressure data in units of 0.01 kPa. The property value range shall be 0x0000 to 0xFFFFD (0 to 655.33 kPa).
- (23) Current value of block pressure data
This property indicates the current value of block pressure data in units of 0.01 kPa. The property value range shall be 0x0000 to 0xFFFFD (0 to 655.33 kPa).
- (24) Number of block pressure/supply pressure error days
This property indicates the number of days on which a block pressure/supply pressure error occurred and the number of such error occurrences. One byte each is used for the number of error days and the number of error occurrences. The property value shall be structured so as to sequentially indicate the number of block pressure error days, the number of supply pressure error days, the number of block pressure error occurrences, and the number of supply pressure error occurrences, beginning with the high-order byte.
- (25) Test call setting
Performs test call operation setup. When “Test call operation ON” (0x41) is set for this property, a test call is originated; however, if “Test call operation OFF” (0x42) is set, the test call stops.

3. 3. 24 Requirements for power distribution board metering class

Class group code : 0x02
 Class code : 0x87
 Instance code : 0x01–0x7F (0x00: All-instance specification code)

Property name	EPC	Contents of property	Data type	Data size	Unit	Access rule	Mandatory	Announcement at status change	Remark
		Value range (decimal notation)							
Operation status	0x80	This property indicates the ON/OFF status.	unsigned char	1 byte	—	Set		○	
		ON=0x30, OFF=0x31				Get	○		
Measured cumulative amount of electric energy (normal direction)	0xC0	This property indicates the measured cumulative amount of electric energy using an 8-digit decimal notation number.	unsigned long	4 bytes	kWh	Get	○		
		0x00000000–0x05F5E0FF (0–99,999,999)							
Measured cumulative amount of electric energy (reverse direction)	0xC1	This property indicates the measured cumulative amount of electric energy using an 8-digit decimal notation number.	unsigned long	4 bytes	kWh	Get	○		
		0x00000000–0x05F5E0FF (0–99,999,999)							
Unit for cumulative amounts of electric energy	0xC2	This property indicates the unit (multiplying factor) used for the measured cumulative amount of electric energy and the historical data of measured cumulative amounts of electric energy.	unsigned char	1 byte	—	Get	○		
		0x00: 1kWh 0x01: 0.1kWh 0x02: 0.01kWh 0x03: 0.001kWh (Initial value) 0x04: 0.0001kWh 0x0A: 10kWh 0x0B: 100kWh 0x0C: 1000kWh 0x0D: 10000kWh							
Historical data of measured cumulative amounts of electric energy (normal direction)	0xC3	This property indicates the day for which the historical data of measured cumulative amounts of electric energy is to be retrieved and the historical data of measured cumulative amounts of electric energy (8 digits), which consists of 48 pieces of half-hourly data for the preceding 24 hours.	unsigned short +unsigned long ×48	194 bytes	kWh	Get			
		0x0000–0x0063 : 0x00000000–0x05F5E0FF (0–99) : (0–99,999,999)							

Historical data of measured cumulative amounts of electric energy (reverse direction)	0xC4	This property indicates the day for which the historical data of measured cumulative amounts of electric energy is to be retrieved and the historical data of measured cumulative amounts of electric energy (8 digits), which consists of 48 pieces of half-hourly data for the preceding 24 hours.	unsigned short +unsigned long ×48	194 bytes	kWh	Get			
		0x0000–0x0063 : 0x00000000–0x05F5E0FF (0–99) : (0–99,999,999)							
Day for which the historical data of measured cumulative amounts of electric energy is to be retrieved	0xC5	This property indicates the day for which the historical data of measured cumulative amounts of electric energy (which consists of 48 pieces of half-hourly data for the preceding 24 hours) is to be retrieved.	unsigned char	1 byte		Set/ Get			
		0x00–0x63 (0–99) 0: current day 1–99: previous day–day that precedes the current day by 99 days							
Measured instantaneous amount of electric energy	0xC6	This property indicates the measured effective instantaneous amount of electric energy in watts.	signed long	4 bytes	W	Get			
		0x80000001–0x7FFFFFFD (-2,147,483,647–2,147,483,645)							
Measured instantaneous currents	0xC7	This property indicates the measured effective instantaneous R and T phase currents in amperes. In the case of a single-phase, two-wire system, 0x7FFE shall be used for the T phase.	signed short ×2	4 bytes	0.1 A	Get			
		0x8001-0x7FFD (R phase) : 0x8001-0x7FFD (T phase) (-3,276.7–3,276.5): (-3,276.7–3,276.5)							
Measured instantaneous voltages	0xC8	This property indicates the measured effective instantaneous R-S(N) and S(N)-T voltages in volts. In the case of a single-phase, two-wire system, 0xFFFFE shall be used for the S(N)-T voltage.	unsigned short ×2	4 bytes	0.1 V	Get			
		0x0000–0xFFFFD (between R and S(N)) : 0x0000–0xFFFFD (between S(N) and T) (0–6,553.3) : (0–6,553.3)							
Measurement channel 1	0xD0	This property indicates the measurement data for Measurement channel 1 (cumulative amount of electric energy (kWh) and effective instantaneous R and T phase currents (amperes)).	unsigned long + signed	8 bytes	kWh + 0.1A ×2	Get			

		Data format for the electric energy: same as 0xC0 Unit: same as 0xC2 Data format for the currents: same as 0xC7	short ×2						
Measurement channel 2	0xD1	This property indicates the measurement data for Measurement channel 2 (cumulative amount of electric energy (kWh) and effective instantaneous R and T phase currents (amperes)).	unsigned long + signed short ×2	8 bytes	kWh + 0.1A ×2	Get			
		Data format for the electric energy: same as 0xC0 Unit: same as 0xC2 Data format for the currents: same as 0xC7							
Measurement channel 3	0xD2	This property indicates the measurement data for Measurement channel 3 (cumulative amount of electric energy (kWh) and effective instantaneous R and T phase currents (amperes)).	unsigned long + signed short ×2	8 bytes	kWh + 0.1A ×2	Get			
		Data format for the electric energy: same as 0xC0 Unit: same as 0xC2 Data format for the currents: same as 0xC7							
Measurement channel 4	0xD3	This property indicates the measurement data for Measurement channel 4 (cumulative amount of electric energy (kWh) and effective instantaneous R and T phase currents (amperes)).	unsigned long + signed short ×2	8 bytes	kWh + 0.1A ×2	Get			
		Data format for the electric energy: same as 0xC0 Unit: same as 0xC2 Data format for the currents: same as 0xC7							
Measurement channel 5	0xD4	This property indicates the measurement data for Measurement channel 5 (cumulative amount of electric energy (kWh) and effective instantaneous R and T phase currents (amperes)).	unsigned long + signed short ×2	8 bytes	kWh + 0.1A ×2	Get			
		Data format for the electric energy: same as 0xC0 Unit: same as 0xC2 Data format for the currents: same as 0xC7							
Measurement channel 6	0xD5	This property indicates the measurement data for Measurement channel 6 (cumulative amount of electric energy (kWh) and effective instantaneous R and T phase currents (amperes)).	unsigned long + signed short ×2	8 bytes	kWh + 0.1A ×2	Get			
		Data format for the electric energy: same as 0xC0 Unit: same as 0xC2 Data format for the currents: same as 0xC7							

Measurement channel 7	0xD6	This property indicates the measurement data for Measurement channel 7 (cumulative amount of electric energy (kWh) and effective instantaneous R and T phase currents (amperes)).	unsigned long + signed short ×2	8 bytes	kWh + 0.1A ×2	Get			
		Data format for the electric energy: same as 0xC0 Unit: same as 0xC2 Data format for the currents: same as 0xC7							
Measurement channel 8	0xD7	This property indicates the measurement data for Measurement channel 8 (cumulative amount of electric energy (kWh) and effective instantaneous R and T phase currents (amperes)).	unsigned long + signed short ×2	8 bytes	kWh + 0.1A ×2	Get			
		Data format for the electric energy: same as 0xC0 Unit: same as 0xC2 Data format for the currents: same as 0xC7							
Measurement channel 9	0xD8	This property indicates the measurement data for Measurement channel 9 (cumulative amount of electric energy (kWh) and effective instantaneous R and T phase currents (amperes)).	unsigned long + signed short ×2	8 bytes	kWh + 0.1A ×2	Get			
		Data format for the electric energy: same as 0xC0 Unit: same as 0xC2 Data format for the currents: same as 0xC7							
Measurement channel 10	0xD9	This property indicates the measurement data for Measurement channel 10 (cumulative amount of electric energy (kWh) and effective instantaneous R and T phase currents (amperes)).	unsigned long + signed short ×2	8 bytes	kWh + 0.1A ×2	Get			
		Data format for the electric energy: same as 0xC0 Unit: same as 0xC2 Data format for the currents: same as 0xC7							
Measurement channel 11	0xDA	This property indicates the measurement data for Measurement channel 11 (cumulative amount of electric energy (kWh) and effective instantaneous R and T phase currents (amperes)).	unsigned long + signed short ×2	8 bytes	kWh + 0.1A ×2	Get			
		Data format for the electric energy: same as 0xC0 Unit: same as 0xC2 Data format for the currents: same as 0xC7							
Measurement channel 12	0xDB	This property indicates the measurement data for Measurement channel 12 (cumulative amount of electric energy (kWh) and effective instantaneous R and T phase currents (amperes)).	unsigned long + signed	8 bytes	kWh + 0.1A ×2	Get			

		Data format for the electric energy: same as 0xC0 Unit: same as 0xC2 Data format for the currents: same as 0xC7	short ×2						
Measurement channel 13	0xDC	This property indicates the measurement data for Measurement channel 13 (cumulative amount of electric energy (kWh) and effective instantaneous R and T phase currents (amperes)).	unsigned long + signed short ×2	8 bytes	kWh + 0.1A ×2	Get			
		Data format for the electric energy: same as 0xC0 Unit: same as 0xC2 Data format for the currents: same as 0xC7							
Measurement channel 14	0xDD	This property indicates the measurement data for Measurement channel 14 (cumulative amount of electric energy (kWh) and effective instantaneous R and T phase currents (amperes)).	unsigned long + signed short ×2	8 bytes	kWh + 0.1A ×2	Get			
		Data format for the electric energy: same as 0xC0 Unit: same as 0xC2 Data format for the currents: same as 0xC7							
Measurement channel 15	0xDE	This property indicates the measurement data for Measurement channel 15 (cumulative amount of electric energy (kWh) and effective instantaneous R and T phase currents (amperes)).	unsigned long + signed short ×2	8 bytes	kWh + 0.1A ×2	Get			
		Data format for the electric energy: same as 0xC0 Unit: same as 0xC2 Data format for the currents: same as 0xC7							
Measurement channel 16	0xDF	This property indicates the measurement data for Measurement channel 16 (cumulative amount of electric energy (kWh) and effective instantaneous R and T phase currents (amperes)).	unsigned long + signed short ×2	8 bytes	kWh + 0.1A ×2	Get			
		Data format for the electric energy: same as 0xC0 Unit: same as 0xC2 Data format for the currents: same as 0xC7							
Measurement channel 17	0xE0	This property indicates the measurement data for Measurement channel 17 (cumulative amount of electric energy (kWh) and effective instantaneous R and T phase currents (amperes)).	unsigned long + signed short ×2	8 bytes	kWh + 0.1A ×2	Get			
		Data format for the electric energy: same as 0xC0 Unit: same as 0xC2 Data format for the currents: same as 0xC7							

Measurement channel 18	0xE1	This property indicates the measurement data for Measurement channel 18 (cumulative amount of electric energy (kWh) and effective instantaneous R and T phase currents (amperes)). Data format for the electric energy: same as 0xC0 Unit: same as 0xC2 Data format for the currents: same as 0xC7	unsigned long + signed short ×2	8 bytes	kWh + 0.1A ×2	Get			
Measurement channel 19	0xE2	This property indicates the measurement data for Measurement channel 19 (cumulative amount of electric energy (kWh) and effective instantaneous R and T phase currents (amperes)). Data format for the electric energy: same as 0xC0 Unit: same as 0xC2 Data format for the currents: same as 0xC7	unsigned long + signed short ×2	8 bytes	kWh + 0.1A ×2	Get			
Measurement channel 20	0xE3	This property indicates the measurement data for Measurement channel 20 (cumulative amount of electric energy (kWh) and effective instantaneous R and T phase currents (amperes)). Data format for the electric energy: same as 0xC0 Unit: same as 0xC2 Data format for the currents: same as 0xC7	unsigned long + signed short ×2	8 bytes	kWh + 0.1A ×2	Get			
Measurement channel 21	0xE4	This property indicates the measurement data for Measurement channel 21 (cumulative amount of electric energy (kWh) and effective instantaneous R and T phase currents (amperes)). Data format for the electric energy: same as 0xC0 Unit: same as 0xC2 Data format for the currents: same as 0xC7	unsigned long + signed short ×2	8 bytes	kWh + 0.1A ×2	Get			
Measurement channel 22	0xE5	This property indicates the measurement data for Measurement channel 22 (cumulative amount of electric energy (kWh) and effective instantaneous R and T phase currents (amperes)). Data format for the electric energy: same as 0xC0 Unit: same as 0xC2 Data format for the currents: same as 0xC7	unsigned long + signed short ×2	8 bytes	kWh + 0.1A ×2	Get			
Measurement channel 23	0xE6	This property indicates the measurement data for Measurement channel 23 (cumulative amount of electric energy (kWh) and effective instantaneous R and T phase currents (amperes)).	unsigned long + signed	8 bytes	kWh + 0.1A ×2	Get			

		Data format for the electric energy: same as 0xC0 Unit: same as 0xC2 Data format for the currents: same as 0xC7	short ×2						
Measurement channel 24	0xE7	This property indicates the measurement data for Measurement channel 24 (cumulative amount of electric energy (kWh) and effective instantaneous R and T phase currents (amperes)).	unsigned long + signed short ×2	8 bytes	kWh + 0.1A ×2	Get			
		Data format for the electric energy: same as 0xC0 Unit: same as 0xC2 Data format for the currents: same as 0xC7							
Measurement channel 25	0xE8	This property indicates the measurement data for Measurement channel 25 (cumulative amount of electric energy (kWh) and effective instantaneous R and T phase currents (amperes)).	unsigned long + signed short ×2	8 bytes	kWh + 0.1A ×2	Get			
		Data format for the electric energy: same as 0xC0 Unit: same as 0xC2 Data format for the currents: same as 0xC7							
Measurement channel 26	0xE9	This property indicates the measurement data for Measurement channel 26 (cumulative amount of electric energy (kWh) and effective instantaneous R and T phase currents (amperes)).	unsigned long + signed short ×2	8 byte	kWh + 0.1A ×2	Get			
		Data format for the electric energy: same as 0xC0 Unit: same as 0xC2 Data format for the currents: same as 0xC7							
Measurement channel 27	0xEA	This property indicates the measurement data for Measurement channel 27 (cumulative amount of electric energy (kWh) and effective instantaneous R and T phase currents (amperes)).	unsigned long + signed short ×2	8 bytes	kWh + 0.1A ×2	Get			
		Data format for the electric energy: same as 0xC0 Unit: same as 0xC2 Data format for the currents: same as 0xC7							
Measurement channel 28	0xEB	This property indicates the measurement data for Measurement channel 28 (cumulative amount of electric energy (kWh) and effective instantaneous R and T phase currents (amperes)).	unsigned long + signed short ×2	8 byte	kWh + 0.1A ×2	Get			
		Data format for the electric energy: same as 0xC0 Unit: same as 0xC2 Data format for the currents: same as 0xC7							

Measurement channel 29	0xEC	This property indicates the measurement data for Measurement channel 29 (cumulative amount of electric energy (kWh) and effective instantaneous R and T phase currents (amperes)).	unsigned long + signed short ×2	8 bytes	kWh + 0.1A ×2	Get			
		Data format for the electric energy: same as 0xC0 Unit: same as 0xC2 Data format for the currents: same as 0xC7							
Measurement channel 30	0xED	This property indicates the measurement data for Measurement channel 30 (cumulative amount of electric energy (kWh) and effective instantaneous R and T phase currents (amperes)).	unsigned long + signed short ×2	8 bytes	kWh + 0.1A ×2	Get			
		Data format for the electric energy: same as 0xC0 Unit: same as 0xC2 Data format for the currents: same as 0xC7							
Measurement channel 31	0xEE	This property indicates the measurement data for Measurement channel 31 (cumulative amount of electric energy (kWh) and effective instantaneous R and T phase currents (amperes)).	unsigned long + signed short ×2	8 bytes	kWh + 0.1A ×2	Get			
		Data format for the electric energy: same as 0xC0 Unit: same as 0xC2 Data format for the currents: same as 0xC7							
Measurement channel 32	0xEF	This property indicates the measurement data for Measurement channel 32 (cumulative amount of electric energy (kWh) and effective instantaneous R and T phase currents (amperes)).	unsigned long + signed short ×2	8 bytes	kWh + 0.1A ×2	Get			
		Data format for the electric energy: same as 0xC0 Unit: same as 0xC2 Data format for the currents: same as 0xC7							

Note: In the “Announcement at status change” column, ○ denotes mandatory processing when the property is implemented.

- (1) Operation status (a property inherited from the device object super class)
This property indicates whether the functions specific to this class are operating (ON) or not (OFF). In the case of a node in which this class is implemented and the functions specific to this class start operating upon startup of the node, this property may be implemented with the value fixed at 0x30 (operation status ON).
- (2) Measured cumulative amount of electric energy (normal and reverse directions)
This property indicates the measured cumulative amount of electric energy using an

8-digit decimal notation number. The property value for the normal direction is the value for the power flow, and the property value for the reverse direction is the value for the reverse power flow. The unit is indicated by the “Unit for measured cumulative amounts of electric energy” property (EPC=0xC1). When the value of the “Unit for measured cumulative amounts of electric energy” property (which indicates the multiplying factor for measured cumulative amounts of electric energy) is 0x00, 0x01, 0x02, 0x03, 0x04, 0x0A, 0x0B, 0x0C or 0x0D, the unit shall be 1kWh, 0.1kWh, 0.01kWh, 0.001kWh, 0.0001kWh, 10kWh, 100kWh, 1000kWh or 10000kWh, respectively. The property value range is from 0x00000000 to 0x05F5E0FF (from 0 to 99,999,999). In the event of a measured cumulative electric energy amount overflow, the counting of the measured cumulative amount of electric energy shall be restarted from 0x00000000.

Example:

If the value of the “Measured cumulative amount of electric energy” property indicates that the measured cumulative amount of electric energy is 12345678 and the value of the “Unit for measured cumulative amounts of electric energy” property is 0x03, the actual measured cumulative amount would be:

$$12345678 \times 0.001\text{kWh} = 12345.678\text{kWh}$$

Overflow : Counting shall be restarted from 0x00000000.

No data : 0xFFFFFFFFE

(3) Unit for measured cumulative amounts of electric energy

This property indicates the unit for measured cumulative amounts of electric energy (EPC=0xC0, 0xC1).

Property value	Unit (multiplying factor) for measured cumulative amounts of electric energy
0x00	1kWh
0x01	0.1kWh
0x02	0.01kWh
0x03	0.001kWh
0x04	0.0001kWh
0x0A	10kWh
0x0B	100kWh
0x0C	1000kWh
0x0D	10000kWh

(4) Historical data of measured cumulative amounts of electric energy (normal and

reverse directions)

This property indicates the current setting of the “Day for which the historical data of measured cumulative amounts of electric energy is to be retrieved” property (EPC=0xC5; value range = 0x00–0x63 (0–99)) and the historical data of measured cumulative amounts of electric energy for the day specified by the “Day for which the historical data of measured cumulative amounts of electric energy is to be retrieved” property, which consists of 48 pieces of half-hourly data for the preceding 24 hours. The unit is indicated by the “Unit for measured cumulative amounts of electric energy” property. When the value of the “Unit for measured cumulative amounts of electric energy” property is 0x00, 0x01, 0x02, 0x03, 0x04, 0x0A, 0x0B, 0x0C or 0x0D, the unit shall be 1kWh, 0.1kWh, 0.01kWh, 0.001kWh, 0.0001kWh, 10kWh, 100kWh, 1000kWh or 10000kWh, respectively. The half-hourly cumulative electric energy amount measurements shall be measurements that have been taken every hour and every half-hour by reference to the time specified by the “Current time setting” property (EPC=0x97). The (8-digit) measurements (these are the measurements from the meter, not the cumulated amounts for the 30 minute-periods) shall be stored in the order they have been taken, with the oldest and newest measurements stored in the highest-order and lowest-order bytes, respectively. The value range is from 0x00000000 to 0x05F5E0FF (from 0 to 99,999,999). For the hours and half hours at which the amount of electric energy was not measured, 0xFFFFFFFF shall be used as the historical data value.

- (5) Day for which the historical data of measured cumulative amounts of electric energy is to be retrieved (normal and reverse directions)

Specifies the day for which the historical data of measured cumulative amounts of electric energy (EPC=0xC3, C4) is to be retrieved. The value range is from 0x00 to 0x63 (from 0 to 99).

0x00 (0): historical data for the current day (up to the last hour)

0x63 (99): historical data for the day that precedes the current day by 99 days

When there is no data for the specified day, the “Day for which the historical data of measured cumulative amounts of electric energy is to be retrieved” setting of the “Historical data of measured cumulative amounts of electric energy” property shall be set to 0xFF and all half-hourly value settings shall be set to 0xFFFFFFFF.

- (6) Measured instantaneous amount of electric energy

This property indicates the measured effective instantaneous amount of electric energy in watts. The value range is from 0x80000001 to 0x7FFFFFFD (from -2147483647 to 2147483645).

Value range: from -2,147,483,647 to 2,147,483,645W (unit of measurement: watts)

*Underflow : 0x80000000
Overflow : 0x7FFFFFFF
No data : 0x7FFFFFFE

(7) Measured instantaneous currents

This property indicates the measured effective instantaneous R and T phase currents in increments of 0.1A. The value range is from 0x8001 to 0x7FFD (from -3276.7 to 3276.5).

(In the case of a single-phase, two-wire system, the data shall be stored in the R phase field and 0x7FFE shall be set in the T phase field.)

Range: from -3276.7 to 3276.5A (unit of measurement: 0.1A)

Example:

single-phase, three-wire system: 0x03E9 0x03E7 → 100.1,099.9 (A)

single-phase, two-wire system: 0xFC19 0x7FFE → -99.9 not measured (A)

*Underflow : 0x8000

Overflow : 0x7FFF

No data : 0x7FFE

(8) Measured instantaneous voltages

This property indicates the measured effective instantaneous R-S(N) and S(N)-T voltages in volts. The value range is from 0x0000 to 0xFFFD (from 0 to 6553.3).

(In the case of a single-phase, two-wire system, the data shall be stored in the R-S(N) field and 0xFFFE shall be set in the S(N)-T field.)

Range: from 0.0 to 6553.3V (unit of measurement: 0.1V)

Example:

single-phase, three-wire system: 0x0451 0x03E7 → 110.5 099.9 (V)

single-phase, two-wire system: 0x03E7 0xFFFE → 99.9 not measured (V)

*Overflow : 0xFFFF

No data : 0xFFFE

(9) Measurement channels 1 to 32

This property indicates the cumulative amount of electric energy (in kWh) and effective instantaneous currents (in increments of 0.1A) for the respective measurement channel (each EPC code).

The data format for the cumulative amount of electric energy is the same as that for the “Measured cumulative amount of electric energy” property (0xC0). The format

for the effective instantaneous currents is the same as that for the “Measured instantaneous currents” property (0xC7). The unit for the cumulative amount of electric energy is the same as that for the “Unit for cumulative amounts of electric energy” property (0xC2).

* The voltage values shall be taken from 0xC8.

3. 3. 25 Requirements for smart electric energy meter class

Class group code : 0x02
Class code : 0x88
Instance code : 0x01–0x7F (0x00: All-instance specification code)

Property name	EPC	Contents of property	Data type	Data size	Unit	Access rule	Mandatory	Announcement at status change	Remark
		Value range (decimal notation)							
Operation status	0x80	This property indicates the ON/OFF status.	unsigned char	1 byte	—	Set		○	
		ON = 0x30, OFF = 0x31							
Electric energy meter classification	0xD0	This property indicates the electric energy meter type.	unsigned char	1 byte	—	Set/Get			
		0x30: Electric utility company 0x31: Solar power 0x32: Fuel cell 0x33: Battery 0x34: EV 0x35: Others							
Owner classification	0xD1	This property indicates the type of owner of the meter.	unsigned char	1 byte	—	Set/Get			
		0x30: Not specified 0x31: Electric utility company 0x32: Other than electric utility company 0x33: Individual							
Phases and wire setting status	0xD2	This property indicates the phases and wire setting status.	unsigned char	1 byte	—	Get			
		Single-phase, two-wire system: 0x30 Single-phase, three-wire system: 0x31 Three-phase, three-wire system: 0x32 Three-phase, four-wire system: 0x33							
Composite transformation ratio	0xD3	This property indicates the composite transformation ratio using a 6-digit decimal notation number.	unsigned long	4 bytes	—	Get			
		0x00000000–0x000F423F (000000–999999)							
Multiplying factor for composite transformation ratio	0xD4	This property indicates the multiplying factor for the composite transformation ratio.	unsigned char	1 byte	—	Get			
		0x00: ×1 0x01: ×0.1 0x02: ×0.01 0x03: ×0.001							

Meter type certification number	0xD5	This property indicates the type-certified meter number using a string of 10 alphanumeric characters	unsigned char × 10	10 bytes	—	Get			
		(Based on the numbering rule of type-certified meter)							
Year and month of inspection expiry	0xD6	This property indicates the year and month of inspection expiry of the meter by a six-byte ASCII code.	unsigned char × 6	6 bytes	—	Set/Get			
		YYYYMM YYYY (Year), MM (Month)							
Number of effective digits for cumulative amounts of electric energy	0xD7	This property indicates the number of effective digits for measured cumulative amounts of electric energy.	unsigned char	1 byte	digit	Get	○		
		0x01–0x08 (1–8)							
Measured cumulative amount of electric energy (normal direction)	0xE0	This property indicates the measured cumulative amount of electric energy using an 8-digit decimal notation number.	unsigned long	4 bytes	kWh	Get	○		Note 1
		0x00000000–0x05F5E0FF (0–99,999,999)							
Unit for cumulative amounts of electric energy (normal and reverse directions)	0xE1	This property indicates the unit (multiplying factor) used for the measured cumulative amount of electric energy and the historical data of measured cumulative amounts of electric energy.	unsigned char	1 byte	—	Get	○		
		0x00: 1kWh 0x01: 0.1kWh 0x02: 0.01kWh 0x03: 0.001kWh 0x04: 0.0001kWh 0x0A: 10kWh 0x0B: 100kWh 0x0C: 1000kWh 0x0D: 10000kWh							
Historical data of measured cumulative amounts of electric energy 1 (normal direction)	0xE2	This property indicates the day for which the historical data of measured cumulative amounts of electric energy is to be retrieved 1 and the historical data of measured cumulative amounts of electric energy (normal direction), which consists of 48 items of half-hourly data for the preceding 24 hours (00:00 to 23:30) of the day by time series from the highest-order byte.	unsigned short + unsigned long × 48	194 bytes	kWh	Get			
		0x0000–0x0063: 0x00000000–0x05F5E0FF (0–99):(0–99,999,999)							
Measured cumulative amounts of electric energy	0xE3	This property indicates the measured cumulative amounts of electric energy using an 8-digit decimal notation number.	unsigned long	4 bytes	kWh	Get			

(reverse direction)		0x00000000-0x05F5E0FF (0-99,999,999)							
Historical data of measured cumulative amounts of electric energy 1 (reverse direction)	0xE4	This property indicates the day for which the historical data of measured cumulative amounts of electric energy is to be retrieved 1 and the historical data of measured cumulative amounts of electric energy (reverse direction), which consists of 48 items of half-hourly data for the preceding 24 hours (00:00 to 23:30) of the day by time series from the highest-order byte.	unsigned short +unsigned long × 48	194 bytes	kWh	Get			
		0x0000-0x0063: 0x00000000-0x05F5E0FF (0-99): (0-99,999,999)							
Day for which the historical data of measured cumulative amounts of electric energy is to be retrieved 1	0xE5	This property indicates the day for which the historical data of measured cumulative amounts of electric energy (which consists of 48 items of half-hourly data for the preceding 24 hours) is to be retrieved.	unsigned char	1 byte		Set/Get			
		0x00-0x63 (0-99) 0: current day 1-99: previous day – day that precedes the current day by 99 days							
Measured instantaneous electric energy	0xE7	This property indicates the measured effective instantaneous electric energy in watts.	signed long	4 bytes	W	Get			
		0x80000001-0x7FFFFFFD (-2,147,483,647-2,147,483,645)							
Measured instantaneous currents	0xE8	This property indicates the measured effective instantaneous R and T phase currents in amperes. In the case of a single-phase, two-wire system, 0x7FFE shall be used for the T phase.	signed short × 2	4 bytes	0.1 A	Get			
		0x8001-0x7FFD (R phase): 0x8001-0x7FFD (T phase) (-3,276.7-3,276.5): (-3,276.7-3,276.5)							
Measured instantaneous voltages	0xE9	This property indicates the measured effective instantaneous R-S(N) and S(N)-T voltages in volts. In the case of a single-phase, two-wire system, 0xFFFFE shall be used for the S(N)-T voltage.	unsigned short × 2	4 bytes	0.1 V	Get			
		0x0000-0xFFFFD (between R and S(N)): 0x0000-0xFFFFD (between S(N) and T) (0-6,553.3): (0-6,553.3)							

Cumulative amounts of electric energy measured at fixed time (normal direction)	0xEA	<p>This property indicates the most recent cumulative amount of electric energy (normal direction) measured at 30-minute intervals held by the meter in the format of 4 bytes for date of measurement, 3 bytes for time of measurement, and 4 bytes for cumulative electric energy (normal direction).</p> <p>date of measurement YYYY:MM:DD time of measurement hh:mm:ss cumulative electric energy: an 8-digit decimal notation number</p> <p>1-4 bytes: date of measurement YYYY: 0x0001-0x270F (1-9999) MM: 0x01-0x0C (1-12) DD: 0x01-0x1F (1-31) 5-7 bytes: time of measurement hh: 0x00-0x17 (0-23) mm: 0x00-0x3B (0-59) ss: 0x00-0x3B (0-59) 8-11 bytes: 0x00000000-0x05F5E0FF (0-99,999,999)</p>	unsigned char × 4 + unsigned char × 3 + unsigned long	11 bytes	year, month, day, hour minute, second and kWh	Get	○		Note 1
Cumulative amounts of electric energy measured at fixed time (reverse direction)	0xEB	<p>This property indicates the most recent cumulative amount of electric energy (reverse direction) measured at 30-minute intervals held by the meter in the format of 4 bytes for date of measurement, 3 bytes for time of measurement, and 4 bytes for cumulative electric energy (reverse direction).</p> <p>date of measurement YYYY:MM:DD time of measurement hh:mm:ss cumulative electric energy: an 8-digit decimal notation number</p> <p>1-4 bytes: date of measurement YYYY: 0x0001-0x270F (1-9999) MM: 0x01-0x0C (1-12) DD: 0x01-0x1F (1-31) 5-7 bytes: time of measurement hh: 0x00-0x17 (0-23) mm: 0x00-0x3B (0-59) ss: 0x00-0x3B (0-59) 8-11 bytes: 0x00000000-0x05F5E0FF (0-99,999,999)</p>	unsigned char × 4 + unsigned char × 3 + unsigned long	11 bytes	year, month, day, hour minute, second and kWh	Get			

<p>Historical data of measured cumulative amounts of electric energy 2 (normal and reverse directions)</p>	<p>0xEC</p>	<p>This property indicates the historical data of measured cumulative amounts of electric energy every 30 minutes in the normal and reverse directions within the past six hours in the form of date and time for which the historical data of measured cumulative amounts of electric energy is to be retrieved, the number of collection segments, and cumulative amount of electric energy (8 digits max).</p> <ul style="list-style-type: none"> • date and time for which the historical data is to be retrieved YYYY:MM:DD:hh:mm • number of collection segments • cumulative amounts of electric energy <p>Decimal notation up to 8 digits (6 hours max)</p> <hr/> <p>1-6 bytes: date and time for which the historical data is to be retrieved YYYY: 0x0001-0x270F (1-9999) MM: 0x01-0x0C (1-12) DD: 0x01-0x1F (1-31) hh: 0x00-0x17 (0-23) mm: 0x00/0x1E (0/30)</p> <p>7 byte: number of collection segments 0x01-0x0C (1-12)</p> <p>8- bytes:</p> <p>Measured cumulative amount of electric energy (normal direction) 0x00000000-0x05F5E0FF (0-99,999,999)</p> <p>Measured cumulative amount of electric energy (reverse direction) 0x00000000-0x05F5E0FF (0-99,999,999)</p>	<p>unsigned short + unsigned char × 4 + unsigned char + (unsigned long + unsigned long) × (Max) 12</p>	<p>Max. 103 bytes</p>	<p>date, time and kWh</p>	<p>Get</p>				
<p>Day for which the historical data of measured cumulative amounts of electric energy is to be retrieved 2</p>	<p>0xED</p>	<p>This property indicates the date and time of historical data of measurements (every 30 minutes) and the number of segments where measurement historical data is collected every 30 minutes.</p> <hr/> <p>1-6 bytes: date and time for which the historical data is to be retrieved YYYY: 0x0001-0x270F (1-9999) MM: 0x01-0x0C (1-12) DD: 0x01-0x1F (1-31) hh: 0x00-0x17 (0-23) mm: 0x00/0x1E (0/30)</p> <p>7 byte: number of collection segments 0x01-0x0C (1-12)</p>	<p>unsigned short + unsigned char × 4 + unsigned char</p>	<p>7 bytes</p>		<p>Set/Get</p>				

Note: In the “Announcement at status change” column, o denotes mandatory processing when the property is implemented.

Note 1: Either 0xE0 (Measured cumulative amount of electric energy in normal direction) or 0xEA (Cumulative amount of electric energy measured at fixed time (normal direction)) shall be mandatory.

- (1) Operation status (a property inherited from the device object super class)
This property indicates whether the functions specific to this class are operating (ON) or not (OFF). In the case of a node in which this class is implemented and the functions specific to this class start operating upon startup of the node, this property may be implemented with the value fixed at 0x30 (operation status ON).
- (2) Electric energy meter classification
This property indicates the type of electric energy supplied to the meter as electric energy classification.
- (3) Owner classification
This property indicates the owner of the meter in the form of an owner classification.
- (4) Phase and wire setting status
This property indicates the phase and wire setting status metered by the meter. The property value for single-phase, two-wire systems is 0x30, the property value for single-phase, three-wire systems is 0x31, the property value for three-phase, three-wire systems is 0x32 and the property value for three-phase, four-wire systems is 0x33.
- (5) Composite transformation ratio (for the case where a current transformer and a transformer are used)
This property indicates the composite transformation ratio using a 6-digit decimal notation number. The composite transformation ratio of the meter shall be the value specified by the “Composite transformation ratio” property multiplied by the multiplying factor indicated by the “Multiplying factor for composite transformation ratio” property.
- (6) Multiplying factor for composite transformation ratio (for the case where a current transformer and a transformer are used)
This property indicates the multiplying factor for the value specified by the “Composite transformation ratio” property.
The composite transformation ratio of the meter shall be the value specified by the “Composite transformation ratio” property multiplied by the multiplying factor

indicated by the “Multiplying factor for composite transformation ratio” property. Since a meter cannot be connected directly in case of a large current or voltage, the secondary electric energy amount and other values may be measured using a voltage transformer (VT) and a current transformer (CT).

In such a case, the value derived from the measurements taken on the secondary sides of the voltage and current transformers is multiplied by the composite transformation ratio to derive the corresponding primary side value.

Example:

If the power of the meter for a single-phase, three-wire meter of 100V (without voltage transformer) and 200A/5A (with current transformer) is used for 100V, 5A measurement:

- Composite transformation ratio = $(100V/100V) \times (200A/5A) = 40$

- Multiplying factor = 1

- Composite transformation ratio of the meter = composite transformation ratio \times multiplying factor = $40 \times 1 = 40$

Secondary side electric energy = $100V \times 5A \times 2 = 1kW$

The primary side value is derived as follows: $1kW \times 40 = 40kW$.

(7) Meter type certification number

This property indicates the type-certified meter number using a string of 10 alphanumeric characters.

In Japan, this property indicates the type approval number (issued by Japan Electric Meters Inspection Corporation) of the meter. For a non-certified type, 0xFFFFFFFFFFFFFFFF shall be set.

(8) Year and month of inspection expiry

If the meter has been verified by a verifying organization, this property indicates the month and year of inspection expiry as a six-byte ASCII code, in the form of YYYYMM. In the case of July 2012, it is described as 0x323031323037 (201207).

(9) Number of effective digits for cumulative amounts of electric energy

This property indicates the number of effective digits from the low-order side of the measured cumulative amounts of electric energy (data size: 4 bytes, number of digits: 8).

Example:

Number of effective digits for cumulative amounts of electric energy 0x06 (six digits from the low-order side)

The cumulative electric energy value overflows at 0x000F423F (999999) and increments again from 0x00000000(0).

(10) Measured cumulative amount of electric energy (normal direction)

This property indicates the measured cumulative amount of electric energy in the normal direction (power flow) using an 8-digit decimal notation number. The unit is indicated by the “Unit for measured cumulative amounts of electric energy” property (EPC = 0xE1). The property value range is from 0x00000000 to 0x05F5E0FF (from 0 to 99,999,999). If the cumulative electric energy value exceeds the value specified by the “Number of effective digits for cumulative electric energy” property (EPC = 0xD7), the value shall increment again from 0x00000000(0). When “Composite transformation ratio” (EPC = 0xD3) and “Multiplying factor for composite transformation ratio” (EPC = 0xD4) are specified, the measured values on the primary side shall be derived from the composite transformation ratio and the product of composite transformation ratio multiplied by the multiplying factor.

Example:

If the value of the “Measured cumulative amount of electric energy (normal direction)” property indicates that the measured cumulative amount of electric energy is 0x00BC614E (12345678) and the value of the “Unit for measured cumulative amounts of electric energy (EPC = 0xE1)” property is 0x03 (0.001kWh), the actual measured cumulative amount would be:

$12345678 \times 0.001\text{kW} = 12345.678\text{kWh}$
Overflow : Counting shall be restarted from 0x00000000
No data : 0xFFFFFFFFE

(11) Unit for measured cumulative amounts of electric energy (normal and reverse directions)

This property indicates the unit for the measured cumulative amount of electric energy (normal and reverse directions) and the historical data of measured cumulative amounts of electric energy.

Property value	Unit (multiplying factor) for measured cumulative amounts of electric energy
0x00	1kWh
0x01	0.1kWh
0x02	0.01kWh
0x03	0.001kWh

0x04	0.0001kWh
0x0A	10kWh
0x0B	100kWh
0x0C	1000kWh
0x0D	10000kWh

(12) Historical data of measured cumulative amounts of electric energy 1 (normal direction)

This property includes two elements. One is the “day for which the historical data of measured cumulative amounts of electric energy is to be retrieved” 0x0000 to 0x0063 (0 to 99) specified by “Day for which the historical data of measured cumulative amounts of electric energy is to be retrieved 1” (EPC = 0xE5). The other is the historical data of measured cumulative amounts of electric energy in the normal direction (meter reading and not 30-minutes cumulative value) every 30 minutes at 00 and 30 minutes every hour for 24 hours (00:00 to 23:30) on the day, 48 times in total, by time series from the highest-order byte.

This property indicates the cumulative amounts of electric energy using an 8-digit decimal notation number. The unit is indicated by the “Unit for measured cumulative amounts of electric energy” property (EPC = 0xE1). When “Composite transformation ratio” (EPC = 0xD3) and “Multiplying factor for composite transformation ratio” (EPC = 0xD4) are specified, the primary measured value shall be the product of the “composite transformation ratio” multiplied by the “multiplying factor for composite transformation ratio.” The property value range is from 0x00000000 to 0x05F5E0FF (0 to 99,999,999). If the cumulative amounts of electric energy exceeds the number of effective digits specified by “number of effective digits for cumulative amounts of electric energy” (EPC = 0xD7), the value shall be increased again from 0x00000000(0). The property value shall be set to 0xFFFFFFF0 for no cumulative amounts of electric energy (normal direction).

(13) Measured cumulative amount of electric energy (reverse direction)

This property indicates the measured cumulative amount of electric energy in the reverse direction (reverse power flow) using an 8-digit decimal notation number. The unit is indicated by the “Unit for measured cumulative amounts of electric energy” property (EPC = 0xE1). The property value range is from 0x00000000 to 0x05F5E0FF (from 0 to 99,999,999). If the cumulative electric energy value exceeds the value specified by the “Number of effective digits for cumulative electric energy” property (EPC = 0xD7), the value shall increment again from 0x00000000(0). When “Composite transformation ratio” (EPC = 0xD3) and “Multiplying factor for composite transformation ratio” (EPC = 0xD4) are specified, the measured values on the primary side shall be derived from the composite transformation ratio and the product of composite transformation ratio multiplied by

the multiplying factor.

Overflow : Counting shall be restarted from 0x00000000.
No data : 0xFFFFFFFFE

(14) Historical data of measured cumulative amounts of electric energy 1 (reverse direction)

This property includes two elements. One is the “day for which the historical data of measured cumulative amounts of electric energy is to be retrieved” 0x0000 to 0x0063 (0 to 99) specified by “Day for which the historical data of measured cumulative amounts of electric energy is to be retrieved 1” (EPC = 0xE5). The other is the historical data of measured cumulative amounts of electric energy in the reverse direction (meter reading and not 30-minutes cumulative value) every 30 minutes at 00 and 30 minutes every hour for 24 hours (00:00 to 23:30) on the day, 48 times in total, by time series from the highest-order byte.

This property indicates the cumulative amounts of electric energy using an 8-digit decimal notation number. The unit is indicated by the “Unit for measured cumulative amounts of electric energy” property (EPC = 0xE1). When “Composite transformation ratio” (EPC = 0xD3) and “Multiplying factor for composite transformation ratio” (EPC = 0xD4) are specified, the primary measured value shall be the product of the “composite transformation ratio” multiplied by the “multiplying factor for composite transformation ratio.” The property value range is from 0x00000000 to 0x05F5E0FF (0 to 99,999,999). If the cumulative amounts of electric energy exceed the number of effective digits specified by “number of effective digits for cumulative amounts of electric energy” (EPC = 0xD7), the value shall be increased again from 0x00000000(0). The property value shall be set to 0xFFFFFFFFE for no cumulative amounts of electric energy (reverse direction).

(15) Day for which the historical data of measured cumulative amounts of electric energy is to be retrieved 1

This property specifies the day for which the historical data of measured cumulative amounts of electric energy 1 (EPC = 0xE2, 0xE4) is to be retrieved. The value range is from 0x00 to 0x63 (from 0 to 99).

0x00 (0): historical data for the current day (up to the last hour)

0x63 (99): historical data for the day that precedes the current day by 99 days

When there is no data for the specified day, the “Day for which the historical data of measured cumulative amounts of electric energy is to be retrieved” setting of the “Historical data of measured cumulative amounts of electric energy” property shall be set to 0xFF and all half-hourly value settings shall be set to 0xFFFFFFFFE.

(16) Measured instantaneous electric energy

This property indicates the measured effective instantaneous electric energy in watts. The value range is from 0x80000001 to 0x7FFFFFFD (from -2147483647 to 2147483645).

Range: from -2,147,483,647 to 2,147,483,645W (unit of measurement: watts)

*Underflow : 0x80000000
Overflow : 0x7FFFFFFF
No data : 0x7FFFFFFE

(17) Measured instantaneous currents

This property indicates the measured effective instantaneous R and T phase currents in amperes. The value range is from 0x8001 to 0x7FFD (from -3276.7 to 3276.5).

(In the case of a single-phase, two-wire system, the data shall be stored in the R phase field and 0x7FFE shall be set in the T phase field.)

Range: from -3276.7 to 3276.5A (unit of measurement: 0.1A)

Example:

single-phase, three-wire system: 0x03E9 0x03E7 → 100.1,099.9 (A)

single-phase, two-wire system: 0xFC19 0x7FFE → -99.9 not measured (A)

*Underflow : 0x8000
Overflow : 0x7FFF
No data : 0x7FFE

(18) Measured instantaneous voltages

This property indicates the measured effective instantaneous R-S(N) and S(N)-T voltages in volts. The value range is from 0x0000 to 0xFFFFD (from 0 to 6553.3).

(In the case of a single-phase, two-wire system, the data shall be stored in the R-S(N) field and 0xFFFFE shall be set in the S(N)-T field.)

Range: from 0.0 to 6553.3V (unit of measurement: 0.1V)

Example:

single-phase, three-wire system: 0x0451 0x03E7 → 110.5 099.9 (V)

single-phase, two-wire system: 0x03E7 0xFFFFE → 99.9 not measured (V)

*Overflow : 0xFFFF
No data : 0xFFFFE

(19) Cumulative amounts of electric energy measured at fixed time (normal direction)

This property indicates the cumulative amounts of electric energy (normal direction) measured at 30-minute intervals (every half hour) (meter reading and not 30-minute

cumulative value) held by the meter in the format of 4 bytes for date of measurement, 3 bytes for time of measurement, and 4 bytes for cumulative electric energy (normal direction). The date of measurement shall be indicated in the format of two bytes for year, one byte for month, and one byte for day. The time of measurement shall be indicated in the format of one byte for hour, one byte for minute, and one byte for second. If the meter has no second information, 0x00 shall be set for second. The measured cumulative amounts of electric energy shall be indicated using an 8-digit decimal notation number. The unit shall be indicated by the “Unit of cumulative electric energy” property (EPC = 0xE1). When “Composite transformation ratio” (EPC = 0xD3) and “Multiplying factor for composite transformation ratio” (EPC = 0xD4) are specified, the measured values on the primary side shall be derived from the composite transformation ratio and the product of composite transformation ratio multiplied by the multiplying factor. The value range of the property shall be from 0x00000000 to 0x05F5E0FF (0 to 99,999,999). If the cumulative electric energy value exceeds the value specified by the “Number of effective digits for cumulative electric energy” property (EPC = 0xD7), the value shall increment again from 0x00000000(0). If the meter does not support cumulative electric energy (normal direction), 0xFFFFFFFFE shall be set for no data.

Overflow : Counting shall be restarted from 0x00000000
No data : 0xFFFFFFFFE

Example:

Cumulative amounts of electric energy measured at fixed time (normal direction)

- YYYY = 0x07DC (year: 2012), MM = 0x03 (month: 3), DD = 0x0F (day: 15)

- hh = 0x07 (hour: 7), mm = 0x00 (minute: 0), ss = 0x00 (second: 0)

- Cumulative electric energy (normal direction) = 0x0001E240 (00123456)

Number of effective digits for cumulative electric energy (EPC = 0xD7): 0x06
(low-order six digits)

Unit of cumulative electric energy (EPC = 0xE1): 0x02 (0.01kWh)

Date of measurement: March 15, 2012

Time of measurement: 07:00:00

Cumulative electric energy (normal direction)

$123456 \times 0.01\text{kWh} = 1234.56\text{kWh}$ (measured value)

(20) Cumulative amounts of electric energy measured at fixed time (reverse direction)

This property indicates the cumulative amounts of electric energy (reverse direction) measured at 30-minute intervals (every half hour) (meter reading and not 30-minutes cumulative value) held by the meter in the format of 4 bytes for date of measurement, 3 bytes for time of measurement, and 4 bytes for cumulative electric energy (reverse direction). The date of measurement shall be indicated in the format of two bytes for year, one byte for month, and one byte for day. The time of measurement shall be indicated in the format of one byte for hour, one byte for minute, and one byte for second. If the meter has no second information, 0x00 shall be set for second. The measured cumulative amounts of electric energy shall be indicated using an 8-digit decimal notation number. The unit shall be indicated by the “Unit of cumulative electric energy” property (EPC = 0xE1). When “Composite transformation ratio” (EPC = 0xD3) and “Multiplying factor for composite transformation ratio” (EPC = 0xD4) are specified, the measured values on the primary side shall be derived from the composite transformation ratio and the product of composite transformation ratio multiplied by the multiplying factor. The value range of the property shall be from 0x00000000 to 0x05F5E0FF (0 to 99,999,999). If the cumulative electric energy value exceeds the value specified by the “Number of effective digits for cumulative electric energy” property (EPC = 0xD7), the value shall increment again from 0x00000000(0). If the meter does not support cumulative electric energy (reverse direction), 0xFFFFFFFFE shall be set for no data.

Overflow : Counting shall be restarted from 0x00000000
No data : 0xFFFFFFFFE

Example:

Cumulative amount of electric energy measured at fixed time (reverse direction)

- YYYY = 0x07DC (year: 2012), MM = 0x03 (month: 3), DD = 0x0F (day: 15)

- hh = 0x07 (hour: 7), mm = 0x00 (minute: 0), ss = 0x00 (second: 0)

- Cumulative electric energy (reverse direction) = 0x0001E240 (00123456)

Number of effective digits for cumulative electric energy (EPC = 0xD7): 0x06
(low-order six digits)

Unit of cumulative electric energy (EPC = 0xE1): 0x02 (0.01kWh)

Date of measurement: March 15, 2012

Time of measurement: 07:00:00

Cumulative electric energy (reverse direction)

$123456 \times 0.01\text{kWh} = 1234.56\text{kWh}$ (measured value)

(21) Historical data of measured cumulative amounts of electric energy 2 (normal and reverse directions)

This property includes two elements. One is the date and time for which the historical data of measured cumulative amounts of electric energy is to be retrieved in the format of YYYY:MM:DD:hh:mm, and the number of collection segments specified by “Day for which the historical data of measured cumulative amounts of electric energy is to be retrieved 2” (EPC = 0xED) respectively. The other is the historical data of measured cumulative amount of electric energy every 30 minutes in the normal and reverse directions within the past six hours on the day.

The date and time indicates date by four bytes and time by two bytes in this order. The property value for minutes every hour is 0x00 (0 min) or 0x1E (30 min).

The number of collection segments indicates the count of collecting data about cumulative amount of electric energy every 30 minutes by one byte. The value range is from 0x01 to 0x0C (1 to 12).

Measured cumulative amount of electric energy (meter reading and not 30-minutes cumulative value) is a decimal notation of up to 8 digits. The property of “Unit for measured cumulative amounts of electric energy” (EPC = 0xE1) indicates the unit. When “Composite transformation ratio” (EPC = 0xD3) and “Multiplying factor for composite transformation ratio” (EPC = 0xD4) are specified, the primary value shall be the product of the “composite transformation ratio” multiplied by the “multiplying factor for composite transformation ratio.” The property value range is from 0x00000000 to 0x05F5E0FF (0 to 99,999,999). With the Measured cumulative amount of electric energy (normal and reverse directions) measured at the time set by “date and time for which the historical data is to be retrieved” as the higher-order byte, the property value indicates the number of segments specified by “day for which the historical data of measured cumulative amounts of electric energy is to be retrieved 2” (EPC = 0xED) in reverse time series. If the cumulative amount of electric energy exceeds the number of effective digits specified by “Number of effective digits for cumulative amounts of electric energy” (EPC = 0xD7), the value shall be increased again from 0x00000000(0). When cumulative amount of electric energy is not measured or the data is outside the history retention period, the property value shall be set to 0xFFFFFFFFE for no data.

When “Day for which the historical data of measured cumulative amounts of electric energy is to be retrieved 2” (EPC = 0xED) is not set, the initial value shall be set to 0xFFFFFFFFFFFF for date and time for which the historical data of measured cumulative amounts of electric energy is to be retrieved, 0x01 for the number of segments, and 0xFFFFFFFFE for the 30-minute value of each segment in the normal and reverse directions respectively.

(22) Day for which the historical data of measured cumulative amounts of electric energy

is to be retrieved 2

This property includes two elements. One is the date and time for which the historical data of measured cumulative amounts of electric energy is to be retrieved of a target specified by the “Historical data of measured cumulative amounts of electric energy 2 (normal and reverse directions)” (EPC = 0xEC). The other is the number of collection segments where 30-minute measurement historical data is one segment.

The date and time shall be the latest ones of data collection. The format is two bytes for year, one byte for month, one byte for day, one byte for hour, and one byte for minute. Since “Historical data of measured cumulative amounts of electric energy 2 (normal and reverse directions)” is data collected at every 30 minutes, the minutes value shall be 0x00 (0 minute) or 0x1E (30 minutes).

The number of collection segments indicates the count of collecting data about measured cumulative amount of electric energy every 30 minutes earlier than the date and time for which the historical data is to be retrieved. The property value range is from 0x01 to 0x0C (1 to 12).

The initial value of this property shall be set to 0xFFFFFFFFFFFF for date and time for which the historical data is to be retrieved and 0x01 for the number of collection segments.

3. 3. 26 Requirements for smart gas meter class

Class group code : 0x02
Class code : 0x89
Instance code : 0x01–0x7F (0x00: All-instance specification code)

Property name	EPC	Contents of property	Data type	Data size	Unit	Access rule	Mandatory	Announcement at status change	Remark
		Value range (decimal notation)							
Operation status	0x80	This property indicates the ON/OFF status.	unsigned char	1 byte	—	Set		○	
		ON=0x30, OFF=0x31				Get	○		
Gas meter classification setting	0xE0	This property indicates the type of the gas meter.	unsigned char	1 byte	—	Set/Get			
		0x30: city gas 0x31: LP gas 0x32: natural gas 0x33: others							
Owner classification setting	0xE1	This property indicates the type of owner of the meter.	unsigned char	1 byte	—	Set/Get			
		0x30: not specified 0x31: city gas 0x32: LP gas 0x33: private-sector company 0x34: individual							
Measured cumulative gas consumption	0xE2	This property indicates the measured cumulative gas consumption in m ³ .	unsigned long	4 bytes	0.001 m ³	Get	○		Note1
		0x00000000–0x3B9AC9FF (0–999,999,999m3)							
Unit for measured cumulative gas consumption	0xE3	This property indicates the unit (multiplying factor) for the measured cumulative gas consumption and the historical data of measured cumulative gas consumption.	unsigned char	1 byte	—	Get			
		0x00: 1m ³ 0x01: 0.1m ³ 0x02: 0.01m ³ 0x03: 0.001m ³ 0x04: 0.0001m ³ 0x05: 0.00001m ³ 0x06: 0.000001m ³							
Historical data of measured cumulative gas consumption	0xE4	This property indicates the day for which the historical data of measured cumulative gas consumption is to be retrieved and the historical data of measured cumulative gas consumption, which consists of 48 pieces of half-hourly data for the preceding 24 hours.	unsigned short +unsigned long ×48	194 bytes	0.001m ³	Get			

		0x0000–0x0063: 0x00000000–0x3B9AC9FF (0–99) : (0–999,999.999m ³)							
Day setting for which the historical data of measured cumulative gas consumption is to be retrieved	0xE5	This property indicates the day for which the historical data of measured cumulative gas consumption (which consists of 48 pieces of half-hourly data for the preceding 24 hours) is to be retrieved.	unsigned char	1 byte		Set Get			
		0x00–0x63 (0–99) 0: current day 1–99: previous day–day that precedes the current day by 99 days							
Detection of abnormal value in metering data	0xE6	This property indicates whether the meter has detected an abnormal value in the metering data.	unsigned char	1 byte	—	Get			
		Abnormal value detected: 0x41 No abnormal value detected: 0x42							
Security data information	0xE7	Provides security information about the abnormal states detected by the meter in the form of security data that identifies the abnormal states by means of bit assignment.	unsigned char ×10	10 bytes	—	Get			
		For details, refer to the explanations under (9).							
Valve closure by the Center	0xE8	This property indicates whether the Center has closed the gas shutoff valve of the meter.	unsigned char	1 byte	—	Get			
		Center has closed the valve: 0x41 Center has not closed the valve: 0x42							
Permission from the Center to reopen the valve closed by the Center	0xE9	This property indicates whether permission has been given by the Center to reopen the gas shutoff valve of the meter closed by the Center.	unsigned char	1 byte	—	Get			
		Permission has been given by the Center to reopen the gas shutoff valve closed by the Center: 0x41 Permission to reopen the gas shutoff valve closed by the Center has not been given by the Center: 0x42							
Emergency closure of shutoff valve	0xEA	This property indicates whether the gas shutoff valve of the meter has been closed in response to an emergency.	unsigned char	1 byte	—	Get			
		Emergency closure of the shutoff valve has occurred: 0x41 No emergency closure of the shutoff valve has occurred: 0x42							
Shutoff valve status	0xEB	This property indicates whether the shutoff valve is open or closed.	unsigned char	1 byte	—	Get			
		Shutoff valve open: 0x41 Shutoff valve closed: 0x42							

Historical data of shutoff reasons	0xEC	This property indicates the reasons for the 3 past shutoff valve-based gas shutoffs by means of bit assignment with one byte used for each of the 3 shutoff reasons. Historical data3: Historical data2: Historical data 1	unsigned char ×3	3 bytes	—	Get			
		0xFF: 0xFF: 0xFF							
ID number setting	0xED	This property indicates the ID number of the meter.	unsigned char	6 bytes		Set/Get			
		000000–FFFFFF (Initial value : “000000”)							
Verification expiration setting	0xEE	This property indicates the month and year in which the verification of the meter will expire.	unsigned char	6 bytes		Set/Get			
		YYYYMM YYYY (Year), MM (Month)							
Measured cumulative gas consumption information with date and time	0xD0	This property indicates the cumulative gas consumption and the date and time of measurement. Date of measurement: YYYY:MM:DD Time of measurement: HH:MM:SS Cumulative gas consumption: 9 digits	unsigned char×4+ unsigned char×3+ unsigned long	11 bytes	Date + Time + 0.001m ³	Get	○		Note1
		1–4 bytes: 0–0x270f:1–0x0C:1–0x1F (=0–9999):(=1–12):(1–31) 5–7 bytes: 0–0x17:0–0x3B:0–0x3B (=0–23):(=0–59):(=0–59) 8–11 bytes: 0x00000000–0x3B9AC9FF (0–999,999,999)							
Historical information of cumulative gas consumption	0xD1	This property indicates the historical information of gas consumption measured at every hour, the date and time of history start, cumulative gas consumption at history start and cumulative time interval. Date: YYYY:MM:DD Time: HH:MM:SS Historical information of gas consumption Cumulative gas consumption at history start Cumulative time interval: 5 digits, every minute	unsigned char×4+ unsigned char×3+ unsigned long×24+unsigned long+unsigned short	109 bytes	Date + Time + 0.001m ³ + 0.001m ³ + minute	Get			

	1-4 bytes: 0-0x270f:1-0x0C:1-0x1F (=0-9999):(=1-12):(1-31) 5-7 bytes: 0-0x17:0-0x3B:0-0x3B (=0-23):(=0-59):(=0-59) 8-103 bytes: 0x00000000-0x0001869F×24 (0-99,999m3)×24 104-107 bytes: 0x00000000-0x3B9AC9FF (0-999,999,999 m ³) 108-109 bytes: 0x0001-0xFFFF (1-65535)							
--	--	--	--	--	--	--	--	--

Note: In the “Announcement at status change” column, ○ denotes mandatory processing when the property is implemented.

Note1: EPC shall be 0xE2 (measured cumulative gas consumption) or 0xD0 (measured cumulative gas consumption information with date and time).

- (1) Operation status (a property inherited from the device object super class)
 This property indicates whether the functions specific to this class are operating (ON) or not (OFF). In the case of a node in which this class is implemented and the functions specific to this class start operating upon startup of the node, this property may be implemented with the value fixed at 0x30 (operation status ON).
- (2) Gas meter classification setting
 This property indicates the type of the gas being metered by the meter in the form of meter classification.
- (3) Owner classification setting
 This property indicates the owner of the meter in the form of owner classification.
- (4) Measured cumulative gas consumption
 This property indicates the measured cumulative gas consumption using a 9-digit decimal notation number. The unit is indicated by the “Unit for measured cumulative gas consumption” property (EPC=0xE3). If the Unit property (EPC=0xE3) is not installed, however, the unit shall be 0.001m³. If the Unit property (EPC=0xE3) is installed, the unit shall depend on the property value as specified below. When the value of the “Unit for measured cumulative gas consumption” property (which indicates the multiplying factor for measured cumulative gas consumption) is 0x00, 0x01, 0x02, 0x03, 0x04, 0x05 or 0x06, the unit shall be 1m³, 0.1 m³, 0.01 m³, 0.001 m³, 0.0001 m³, 0.00001 m³ or 0.000001 m³,

respectively. The property value range is from 0x00000000 to 3B9AC9FF (from 0 to 999,999,999). In the event of a measured cumulative gas consumption overflow, the counting of the measured cumulative gas consumption shall be restarted from 0x00000000.

Example:

If the value of the “Measured cumulative gas consumption” property indicates that the measured cumulative gas consumption is 123456789 and the value of the “Unit for measured cumulative gas consumption” property is 0x03, the actual measured cumulative gas consumption would be:

$$123456789 \times 0.001 \text{ m}^3 = 123456.789 \text{ m}^3$$

Overflow : Counting shall be restarted from 0x00000000

No data : 0xFFFFFFFFE

*EPC shall be 0xE2 (measured cumulative gas consumption) or 0xD0 (measured cumulative gas consumption information with date and time).

(5) Unit for measured cumulative gas consumption

This property indicates the unit for measured cumulative gas consumption.

Property value	Cumulative gas consumption (multiplying factor)
0x00	1m ³
0x01	0.1 m ³
0x02	0.01 m ³
0x03	0.001 m ³
0x04	0.0001 m ³
0x05	0.00001 m ³
0x06	0.000001 m ³

*If this property is not installed, the unit for measured cumulative gas consumption shall be 0.001m³.

(6) Historical data of measured cumulative gas consumption

This property indicates the current setting of the “Day for which the historical data of measured cumulative gas consumption is to be retrieved” property (EPC=0xE5; value range = 0x0000–0x0063 (0–99)) and the historical data of measured cumulative gas consumption (unit = 0.001m³) for the day specified by the “Day for which the historical data of measured cumulative gas consumption is to be retrieved” property, which consists of 48 pieces of half-hourly data for the preceding 24 hours. The half-hourly cumulative gas consumption measurements

shall be measurements that have been taken every hour and every half-hour by reference to the time specified by the “Current time setting” property (EPC=0x97). The measurements (unit = 0.001m³) shall be stored in the order they have been taken, with the oldest and newest measurements stored in the highest-order and lowest-order bytes, respectively. The value range is from 0x00000000 to 0x3B9AC9FF (from 0 to 999,999.999m³).

- (7) Day setting for which the historical data of measured cumulative gas consumption is to be retrieved

Specifies the day for which the historical data of measured cumulative gas consumption is to be retrieved. The value range is from 0x00 to 0x63 (from 0 to 99).

0x00 (0): historical data for the current day (up to the last hour)

0x63 (99): historical data for the day that precedes the current day by 99 days

When there is no data for the specified day, the “Day for which the historical data of measured cumulative gas consumption is to be retrieved” setting of the “Historical data of measured cumulative gas consumption” property (EPC = 0xE4) shall be set to 0xFF and all half-hourly value settings shall be set to 0xFFFFFFFFE.

- (8) Detection of abnormal value in metering data

This property indicates whether the meter has detected an abnormal value in the metering data. The property value shall be 0x41 when an abnormal value has been detected and 0x42 when no abnormal value has been detected.

- (9) Security data information

Provides security information about the abnormal states detected by the meter in the form of security data that identifies the abnormal states by means of bit assignment.

	Char1	Char2	Char3	Char4	Char5		Char10
Bit1	Arr01	Arr09	Arr17	Arr25	Arr33		Arr73
Bit2	Arr02	Arr10	Arr18	Arr26	Arr34		Arr74
Bit3	Arr03	Arr11	Arr19	Arr27	Arr35		Arr75
Bit4	Arr04	Arr12	Arr20	Arr28	Arr36	...	Arr76
Bit5	Arr05	Arr13	Arr21	Arr29	Arr37		Arr78
Bit6	Arr06	Arr14	Arr22	Arr30	Arr38		Arr77
Bit7	Arr07	Arr15	Arr23	Arr31	Arr39		Arr79
Bit8	Arr08	Arr16	Arr24	Arr32	Arr40		Arr80

“Arr” refers to “alarm information.”

(10) Valve closure by the Center

This property indicates whether the Center has closed the gas shutoff valve of the meter. When the value of this property is "0x41" (= Center has closed the valve), no request to reopen the valve is accepted until the value for the "Permission from the Center has been given to reopen the gas shutoff valve closed by the Center" state (0x41) is received from the "Permission from the Center to reopen the valve closed by the Center" property.

(11) Permission from the Center to reopen the valve closed by the Center

This property indicates whether permission has been given by the Center to reopen the gas shutoff valve of the meter closed by the Center. The value "0x41" indicates that permission has been given by the Center to reopen the gas shutoff valve closed by the Center, and the value "0x42" indicates that permission to reopen the gas shutoff valve closed by the Center has not been given by the Center.

(12) Emergency closure of shutoff valve

This property indicates whether the gas shutoff valve of the meter has been closed in response to an emergency. The value "0x41" indicates that emergency closure of the shutoff valve has occurred and the value "0x42" indicates that no emergency closure of the shutoff valve has occurred.

(13) Shutoff valve status

This property indicates whether the shutoff valve is open or closed. The value "0x41" indicates that the shutoff valve is open and the value "0x42" indicates that the shutoff valve is closed.

(14) Historical data of shutoff reasons

This property indicates the reasons for the 3 past shutoff valve-based gas shutoffs by means of bit assignment with one byte used for each of the 3 shutoff reasons. The higher-order, intermediate-order and lower-order bytes shall contain Historical data 3 (the reason for the shutoff before the shutoff before the last shutoff), Historical data 2 (the reason for the shutoff before the last shutoff) and Historical data 1 (the reason for the last shutoff), respectively.

(15) ID number setting

This property indicates the ID number of the meter. The ID number shall be a 6-digit code comprised of 6 one-byte alphanumeric characters.

ID numbers are used when there are two or more meters.

(16) Year and month of inspection expiry

When the meter is one that has been verified by a verifying organization, this property indicates the year and month in which the verification of the meter will expire.

(17) Measured cumulative gas consumption information with date and time

This property indicates the cumulative gas consumption and the date and time of measurement in the format of 4 bytes for date of measurement, 3 bytes for time of measurement, and 4 bytes for cumulative gas consumption. The date of measurement shall be indicated in the format of two bytes for year, one byte for month, and one byte for day. The time of measurement shall be indicated in the format of one byte for hour, one byte for minute, and one byte for second. If the meter has no second information, 0x00 shall be set for second.

Cumulative gas consumption shall follow the definition in (4) "Measured cumulative gas consumption."

(18) Historical information of cumulative gas consumption

This property indicates the historical information of gas consumption measured at every hour in the format of 4 bytes for the date of history start, 3 bytes for the time of history start, 4 bytes \times 24 for historical data of measured cumulative gas consumption, 4 bytes for cumulative gas consumption at history start, and 2 bytes for cumulative time interval.

The date of history start shall be indicated in the format of two bytes for year, one byte for month, and one byte for day. The time of history start shall be indicated in the format of one byte for hour, one byte for minute, and one byte for second. If the meter has no second information, 0x00 shall be set for second.

Historical data of measured cumulative gas consumption indicates the gas consumption (unit: 0.001m^3) at every cumulative interval using a 5-digit decimal notation number. The value range of the property shall be from 0x00000 to 0xF423F (0 to 99.999m^3).

Cumulative gas consumption at history start shall follow the definition in (4) "Measured cumulative gas consumption."

The value range of cumulative time interval shall be 0x0001 to 0xFFFF (1 to 65535 minutes).

Example:

Sending 24 cumulative values (reading increment at every hour) from 00:00:00 on March 1, 2012 (reading: $123,456.789\text{m}^3$) after 00:00:00 on March 2

Date of history start (YYYY:MM:DD) = 0x07DC0301(2012:03:01)

Time of history start (hh:mm:ss) = 0x000000(00:00:00)

Historical data of measured cumulative gas consumption = See the table below
 (24 from Vol.01 to Vol.24)

Cumulative gas consumption at history start = 0x075BCD15 (123,456.789 m³)

Cumulative time interval = 0x3C (60 minutes)

Supplement) Historical data of measured cumulative gas consumption (example)
 corresponding to the transition of cumulative gas consumption

No.	Year and month	Time	Reading	Historical data of measured cumulative gas consumption
	20120301	000000	123456789	
01	20120301	010000	123456799	00010 (=123456799-123456789)
02	20120301	020000	123456819	00020 (=123456819-123456799)
03	20120301	030000	123456849	00030 (=123456849-123456819)
04	20120301	040000	123456889	00040 (=123456889-123456849)
.
.
.
21	20120301	210000	123461234	01000 (=123461234-123460234)
22	20120301	220000	123461756	00522 (=123461756-123461234)
23	20120301	230000	123461756	00000 (=123461756-123461756)
24	20120302	000000	123461756	00000 (=123461756-123461756)

3. 3. 27 Requirements for general lighting class

Class group code : 0x02

Class code : 0x90

Instance code : 0x01–0x7F (0x00: All-instance specification code)

Property name	EPC	Contents of property	Data type	Data size	Unit	Access rule	Mandatory	Announcement at status change	Remark
		Value range (decimal notation)							
Operation status	0x80	This property indicates the ON/OFF status.	unsigned char	1 byte	—	Set	○	○	
		ON=0x30, OFF=0x31				Get	○		
Illuminance level	0xB0	This property indicates illuminance level in %.	unsigned char	1 byte	%	Set/Get			
		0x00–0x64 (0–100%)							
Light color setting	0xB1	This property indicates the color setting.	unsigned char	1 byte	—	Set/Get			
		Incandescent lamp color = 0x41, white = 0x42, daylight white = 0x43, daylight color = 0x44, other = 0x40							
Illuminance level step setting	0xB2	Used to specify the illuminance level in terms of steps and acquire the current setting.	unsigned char	1 byte	—	Set/Get			
		From 0x01 to the maximum specifiable illuminance level value (dark to bright)							
Light color step setting	0xB3	Used to specify the light color in terms of steps and acquire the current setting.	unsigned char	1 byte	—	Set/Get			
		From 0x01 to the maximum specifiable light color value (incandescent lamp color to white)							
Maximum specifiable values	0xB4	Used to acquire the maximum specifiable illuminance level value and the maximum specifiable light color value of main lighting.	unsigned char ×2	2 bytes	—	Get			
		Byte 1: illuminance Byte 2: light color 0x01–0xFF (Step 1–Step 255) 0x00 (when the function is not implemented)							
Maximum value of settable level for night lighting	0xB5	Used to acquire the maximum values of illuminance and light color settable levels for night lighting.	unsigned char ×2	2 bytes	—	Get			
		First byte: illuminance Second byte: light color 0x01–0xFF (Step 1–Step 255) 0x00 (when the function is not implemented)							
Lighting mode setting	0xB6	Auto/main lighting/night lighting/color lighting	unsigned char	1 byte	—	Set/Get	○		
		Auto=0x41, main lighting=0x42, night lighting=0x43, color lighting=0x45							
Illuminance level setting for main lighting	0xB7	Indicates the illuminance level of main lighting in %.	unsigned char	1 byte	%	Set/Get			
		0x00–0x64(0–100%)							
Illuminance level step setting for	0xB8	Used to set the illuminance level by the number of steps for main lighting and to acquire the current setting.	unsigned char	1 byte	—	Set/Get			

main lighting		0x01 to the maximum value of settable illuminance level(dark to bright)							
Illuminance level setting for night lighting	0xB9	Indicates the illuminance level of night lighting in %.	unsigned char	1 byte	%	Set/Get			
		0x00-0x64 (0-100%)							
Illuminance level step setting for night lighting	0xBA	Used to set the illuminance level by the number of steps for night lighting and to acquire the current setting status.	unsigned char	1 byte	-	Set/Get			
		0x01 to the maximum value of settable illuminance level (dark to bright)							
Light color setting for main lighting	0xBB	Used to set the light color for main lighting.	unsigned char	1 byte	-	Set/Get			
		Incandescent lamp color=0x41, white=0x42, daylight white=0x43, daylight color=0x44, other=0x40							
Light color level step setting for main lighting	0xBC	Used to set the light color level by the number of steps for main lighting and to acquire the current setting.	unsigned char	1 byte	-	Set/Get			
		0x01 to the maximum value of settable light color level (incandescent lamp color to white)							
Light color setting for night lighting	0xBD	Used to set the light color for night lighting.	unsigned char	1 byte	-	Set/Get			
		incandescent lamp color=0x41, white=0x42, daylight white=0x43, daylight color=0x44							
Light color level step setting for night lighting	0xBE	Used to set the light color level by the number of steps for night lighting and to acquire the current setting.	unsigned char	1 byte	-	Set/Get			
		0x01 to the maximum value of settable light color level (incandescent lamp color to white)							
Lighting mode status in auto mode	0xBF	Used to acquire the current lighting mode in auto mode.	unsigned char	1 byte	-	Get			
		main lighting=0x42, night lighting=0x43, off=0x44, color lighting=0x45							
RGB setting for color lighting	0xC0	Used to set the RGB value for color lighting and to acquire the current setting.	unsigned char×3	3 bytes	-	Set/Get			
		Byte 1: R Byte 2: G Byte 3: B 0x00-0xFF (0-255) Minimum brightness=0x00,maximum brightness=0xFF							
ON timer reservation setting	0x90	Reservation ON/OFF	unsigned char	1 byte	-	Set/Get			
		Reservation ON=0x41, Reservation OFF=0x42							
ON timer setting	0x91	Timer value HH:MM	unsigned char ×2	2 bytes	-	Set/Get			
		0-0x17: 0-0x3B (=0-23):(=0-59)							
OFF timer reservation setting	0x94	Reservation ON/OFF	unsigned char	1 byte	-	Set/Get			
		Reservation ON=0x41, Reservation OFF=0x42							

OFF timer setting	0x95	Timer value HH:MM 0-0x17: 0-0x3B (=0-23);(=0-59)	unsigned char ×2	2 bytes	—	Set/Get			
-------------------	------	--	---------------------	---------	---	---------	--	--	--

Note: In the “Announcement at status change” column, ○ denotes mandatory processing when the property is implemented.

(1) Operation status (inherited from the device object super class property)

Operation status ON

When the illuminance level property (0xB0, 0xB2) does not exist: Illuminated.

When the illuminance level property (0xB0, 0xB2) exists: The illuminance level is reflected in the lighting device's illuminance.

When the "Lighting mode" property (0xB6) has Auto mode (0x41), the lighting may be off in Auto mode.

Operation status OFF

Extinguished.

(2) Illuminance level

This property indicates the illuminance level of lighting in % in the current lighting mode setting. This property is used to set the illuminance level and to acquire the current setting. If the illuminance level setting of the actual device is smaller or greater than the property value in %, the value of the actual device shall be assigned to this property.

When this property and the "Illuminance level step setting" property (0xB2) are implemented, their values must be associated with each other.

The Illuminance level setting indicated by this property is that of the actual device when the "Lighting mode setting" property (0xB6) does not have the Auto function (0x41) or when the function is implemented but the lighting mode setting is Main lighting (0x42) or Night lighting (0x43). When the lighting mode setting is Auto (0x41), the illuminance level setting at the time of acquisition is recommended. Since the illuminance level setting indicated by this property is unknown in the Auto status, the property value shall be 0xFD (setting unknown).

Even when the "Operation status" property (0x80) is OFF (0x31), the effectiveness of this property shall be guaranteed.

(3) Light color setting

This property is used to set a light color (incandescent lamp color/white/daylight

white/daylight color/other) of lighting in the current "Lighting mode setting" and to acquire the current setting. "Other" means a light color not belonging to any specified color. Only property values for functions supported by a device of this class may be implemented. For a device of this class not supporting the daylight white function, there is no need to implement 0x43 for daylight white. When this property and the "Light color level step setting" property (EPC=0xB3) are implemented, their values must be associated with each other.

The light color setting indicated by this property is that of the actual device when the "Lighting mode setting" property (0xB6) does not have the Auto function (0x41) or when the function is implemented but the lighting mode setting is Main lighting (0x42) or Night lighting (0x43). When the lighting mode setting is Auto (0x41), the lighting mode setting at the time of acquisition is recommended. Since the light color setting indicated by this property is unknown in the Auto status, the property value shall be 0xFD (setting unknown).

Even when the "Operation status" property (0x80) is OFF (0x31), the effectiveness of this property shall be guaranteed.

(4) Illuminance level step setting

This property indicates the illuminance level of lighting in the current "Lighting mode setting" by the number of steps. This property is also used to set the illuminance level and to acquire the current setting. The maximum value of settable illuminance level is acquired by the "Maximum value of settable level" property (EPC=0xB4) and the "Maximum value of night lighting settable level" property (EPC=0xB5). No actual value is specified for illuminance level. However, the illuminance decreases as the level setting becomes smaller and increases as it becomes greater. Only property values for functions supported by a device of this class may be implemented. When this property and the "Illuminance level setting" property (EPC=0xB0) are implemented, their values must be associated with each other. With this property, the "Maximum settable level" property (0xB4) must be implemented. When the "Night lighting" function (0x43) of the "Lighting mode setting" property (0xB6) is implemented, the "Maximum value of night lighting settable level" property (0xB5) must also be implemented.

The illuminance level step setting indicated by this property is that of the actual device when the "Lighting mode setting" property (0xB6) does not have the Auto function (0x41) or when the function is implemented but the lighting mode setting is Main lighting (0x42) or Night lighting (0x43). When the lighting mode setting is

Auto (0x41), the illuminance level step setting at the time of acquisition is recommended. Since the illuminance level step setting indicated by this property is unknown in the Auto status, the property value shall be 0x00 (setting unknown).

Even when the "Operation status" property (0x80) is OFF (0x31), the effectiveness of this property shall be guaranteed.

(5) Light color step setting

This property indicates the light color level of lighting in the current "Lighting mode setting" by the number of steps. This property is also used to set the light color and to acquire the current setting. The maximum value of settable light color level is acquired by the "Maximum value of settable level" property (EPC=0xB4) and the "Maximum value of night lighting settable level" property (EPC=0xB5). No actual value is specified for light color level. However, the light color becomes closer to incandescent lamp color as the level setting becomes smaller and closer to white as it becomes greater. Only property values for functions supported by a device of this class may be implemented. When this property and the "Light color setting" property (EPC=0xB1) are implemented, their values must be associated with each other. With this property, the "Maximum settable level" property (0xB4) must be implemented. When the "Night lighting" function (0x43) of the "Lighting mode setting" property (0xB6) is implemented, the "Maximum value of night lighting settable level" property (0xB5) must also be implemented.

The light color step setting indicated by this property is that of the actual device when the "Lighting mode setting" property (0xB6) does not have the Auto function (0x41) or when the function is implemented but the lighting mode setting is Main lighting (0x42) or Night lighting (0x43). When the lighting mode setting is Auto (0x41), the light color level step setting at the time of acquisition is recommended. Since the light color level step setting indicated by this property is unknown in the Auto status, the property value shall be 0x00 (setting unknown).

Even when the "Operation status" property (0x80) is OFF (0x31), the effectiveness of this property shall be guaranteed.

(6) Maximum specifiable values

Used to acquire the maximum specifiable illuminance level and light color values for main lighting. This is a 2-byte property. The first byte represents the maximum specifiable illuminance level step value, and the second byte represents the maximum specifiable light color step value. Each of the 2 bytes indicates the respective maximum specifiable value using a 255-step scale (0x01 to 0xFF). The

maximum specifiable value for an unimplemented function shall be 0x00.

(7) Maximum value of settable level for night lighting

Used to acquire the maximum specifiable illuminance level and light color values for night lighting. This is a 2-byte property. The first byte represents the maximum specifiable illuminance level step value, and the second byte represents the maximum specifiable light color step value. Each of the 2 bytes indicates the respective maximum specifiable value using a 255-step scale (0x01 to 0xFF). The maximum specifiable value for an unimplemented function shall be 0x00.

(8) Lighting mode setting

This property is used to set auto, main lighting, night lighting, or color lighting and to acquire the current setting.

Auto (0x41): The lighting instrument automatically selects main lighting or night lighting and controls illuminance level setting, illuminance level step setting, light color setting, or light color level step setting by using illuminance sensors and auto dimming algorithms.

Main lighting (0x42): The main light is lit.

Night lighting (0x43): Not the main light but a night light (such as a midget lamp) is lit.

Color lighting (0x45): Color lights are lit.

Only property values for functions supported by a device of this class may be implemented. For a device of this class not supporting the auto function, there is no need to implement 0x41 for auto.

(9) Illuminance level setting for main lighting

This property indicates the illuminance level in % when the "Lighting mode setting" property (EPC=0xB6) is set to main lighting. This property is also used to set the illuminance level and to acquire the current setting. If the illuminance level setting of the actual device is smaller or greater than the property value in %, the value of the actual device shall be assigned to this property.

This property allows setting and acquisition even when the "Lighting mode setting" property (0xB6) is set to other than main lighting mode. When this property and the "Illuminance level step setting in main lighting mode" property (0xB8) are implemented, their values must be associated with each other.

Even when the "Operation status" property (0x80) is OFF (0x31), the effectiveness of this property shall be guaranteed.

(10) Illuminance level step setting for main lighting

This property indicates the illuminance level by the number of steps when the "Lighting mode setting" property (EPC=0xB6) is set to main lighting. This property is also used to set the illuminance level and to acquire the current setting. The maximum value of settable illuminance level is acquired by the "Maximum value of settable level" property (EPC=0xB4). No actual value is specified for illuminance level. However, the illuminance decreases as the level setting becomes smaller and increases as it becomes greater. Only property values for functions supported by a device of this class may be implemented. When this property and the "Illuminance level setting in main lighting mode" property (EPC=0xB7) are implemented, their values must be associated with each other. With this property, the "Maximum settable level" property (0xB4) must be implemented.

This property allows setting and acquisition even when the "Lighting mode setting" property (0xB6) is set to other than main lighting mode.

Even when the "Operation status" property (0x80) is OFF (0x31), the effectiveness of this property shall be guaranteed.

(11) Illuminance level setting for night lighting

This property indicates the illuminance level in % when the "Lighting mode setting" property (EPC=0xB6) is set to night lighting mode. This property is also used to set the illuminance level and to acquire the current setting. If the illuminance level setting of the actual device is smaller or greater than the property value in %, the value of the actual device shall be assigned to this property.

This property allows setting and acquisition even when the "Lighting mode setting" property (0xB6) is set to other than night lighting mode. When this property and the "Illuminance level step setting in night lighting mode" property (0xBA) are implemented, their values must be associated with each other.

Even when the "Operation status" property (0x80) is OFF (0x31), the effectiveness of this property shall be guaranteed.

(12) Illuminance level step setting for night lighting

This property indicates the illuminance level by the number of steps when the "Lighting mode setting" property (EPC=0xB6) is set to night lighting. This property is also used to set the illuminance level and to acquire the current setting. The maximum value of settable illuminance level is acquired by the "Maximum value of night lighting settable level" property (EPC=0xB5). No actual value is specified for illuminance level. However, the illuminance decreases as the level setting becomes smaller and increases as it becomes greater. Only property values for functions supported by a device of this class may be implemented. When this property and the "Illuminance level step setting in night lighting mode" property (EPC=0xB9) are implemented, their values must be associated with each other. With this property, the "Maximum value of night lighting settable level" property (0xB5) must also be

implemented.

This property allows setting and acquisition even when the "Lighting mode setting" property (0xB6) is set to other than night lighting mode.

Even when the "Operation status" property (0x80) is OFF (0x31), the effectiveness of this property shall be guaranteed.

(13)Light color setting for main lighting

This property is used to set a light color (incandescent lamp color0x41/white0x42/daylight white0x43/daylight color0x44/other0x40) when the "Lighting mode setting" property (EPC=0xB6) is set to main lighting and to acquire the current setting. "Other" means a light color not belonging to any specified color. Only property values for functions supported by a device of this class may be implemented. For a device of this class not supporting the daylight white function, there is no need to implement 0x43 for daylight white.

This property allows setting and acquisition even when the "Lighting mode setting" property (0xB6) is set to other than main lighting mode. When this property and the "Light color level step setting in main lighting mode" property (0xBC) are implemented, their values must be associated with each other.

Even when the "Operation status" property (0x80) is OFF (0x31), the effectiveness of this property shall be guaranteed.

(14)Light color level step setting for main lighting

This property indicates the light color level by the number of steps when the "Lighting mode setting" property (EPC=0xB6) is set to main lighting. This property is also used to set the light color level and to acquire the current setting. The maximum value of settable light color level is acquired by the "Maximum value of settable level" property (EPC=0xB4). No actual value is specified for light color level. However, the light color becomes closer to incandescent lamp color as the level setting becomes smaller and closer to white as it becomes greater. Only property values for functions supported by a device of this class may be implemented. Whenever this property is implemented, the "Maximum value of settable level" property (EPC=0xB4) shall also be implemented.

This property allows setting and acquisition even when the "Lighting mode setting" property (0xB6) is set to other than main lighting mode. When this property and the "Light color setting in main lighting mode" property (0xBB) are implemented, their values must be associated with each other.

Even when the "Operation status" property (0x80) is OFF (0x31), the effectiveness of this property shall be guaranteed.

(15)Light color setting for night lighting

This property is used to set a light color (incandescent lamp color0x41/white0x42/daylight white0x43/daylight color0x44/other0x40) when the "Lighting mode setting" property (EPC=0xB6) is set to night lighting and to acquire the current setting. "Other" means a light color not belonging to any specified color. Only property values for functions supported by a device of this class may be implemented. For a device of this class not supporting the daylight white function, there is no need to implement 0x43 for daylight white.

This property allows setting and acquisition even when the "Lighting mode setting" property (0xB6) is set to other than night lighting mode. When this property and the "Light color level step setting in night lighting mode" property (0xBE) are implemented, their values must be associated with each other.

Even when the "Operation status" property (0x80) is OFF (0x31), the effectiveness of this property shall be guaranteed.

(16)Light color level step setting for night lighting

This property indicates the light color level by the number of steps when the "Lighting mode setting" property (EPC=0xB6) is set to night lighting. This property is also used to set the light color level and to acquire the current setting. The maximum value of settable light color level is acquired by the "Maximum value of night lighting settable level" property (EPC=0xB5). No actual value is specified for light color level. However, the light color becomes closer to incandescent lamp color as the level setting becomes smaller and closer to white as it becomes greater. Only property values for functions supported by a device of this class may be implemented. Whenever this property is implemented, the "Maximum value of night lighting settable level" property (0xB5) shall also be implemented.

This property allows setting and acquisition even when the "Lighting mode setting" property (0xB6) is set to other than night lighting mode. When this property and the "Light color setting in night lighting mode" property (0xBD) are implemented, their values must be associated with each other.

Even when the "Operation status" property (0x80) is OFF (0x31), the effectiveness of this property shall be guaranteed.

(17)Lighting mode status in auto mode

This property is used to acquire the lighting status of an actual device when the "Lighting mode setting" property (EPC=0xB6) is set to auto (0x41), main lighting (0x42), night lighting (0x43), off (0x44), or color lighting (0x45).

Only property values for functions supported by a device of this class may be implemented. For a device of this class not supporting the night lighting function, there is no need to implement 0x43 for night lighting.

(18) RGB setting in color lighting mode

This property is used to set the RGB value when the "Lighting mode setting" property (EPC=0xB6) is set to color lighting (0x45) and to acquire the current setting. No actual value is specified for RGB. Only property values for functions supported by a device of this class may be implemented. If the RGB setting by this property is not acceptable, the closest acceptable value is set. This property allows setting and acquisition even when the "Lighting mode setting" property (0xB6) is set to other than color lighting mode (0x45).

(19) ON timer reservation setting

Specifies whether the ON timer reservation is ON or OFF. This property shall be related to the "ON timer setting" property.

Reservation ON=0x41; reservation OFF=0x42

This property shall be effective even when the value of the "Operation status" property (0x80) is OFF (0x31).

(20) ON timer setting

This property indicates when the setting of the "ON timer reservation setting" property is "ON," the time at which the device will be turned on. The "hour (0x00 to 0x17 (0 to 23)) : minute (0x00 to 0x3B (0 to 59))" format shall be used, with the higher- and lower-order bytes used for the "hour" and "minute" values, respectively. This property shall be effective even when the value of the "Operation status" property (0x80) is OFF (0x31).

(21) OFF timer reservation setting

Specifies whether the OFF timer reservation is ON or OFF. This property shall be related to the "OFF timer setting" property.

Reservation ON=0x41; reservation OFF=0x42

This property shall be effective even when the value of the "Operation status" property (0x80) is OFF (0x31).

(22) OFF timer setting

This property indicates when the setting of the "OFF timer reservation setting" property is "ON," the time at which the device will be turned off. The "hour (0x00 to 0x17 (0 to 23)) : minute (0x00 to 0x3B (0 to 59))" format shall be used, with the higher- and lower-order bytes used for the "hour" and "minute" values, respectively. This property shall be effective even when the value of the "Operation status" property (0x80) is OFF (0x31).

3. 3. 28 Requirements for buzzer class

Class group code : 0x02

Class code : 0xA0

Instance code : 0x01–0x7F (0x00: All-instance specification code)

Property name	EPC	Contents of property	Data type	Data size	Unit	Access rule	Mandatory	Announcement at status change	Remark
		Value range (decimal notation)							
Operation status	0x80	This property indicates the ON/OFF status.	unsigned char	1 byte	—	Set		○	
		ON=0x30, OFF=0x31				Get			
Sound generation setting	0xB1	This property indicates buzzer sound generation setting.	unsigned char	1 byte	–	Set/Get			
		Buzzer enabled = 0x41, buzzer disabled = 0x42							
Buzzer sound type	0xE0	This property indicates 8 different types of buzzer sound.	unsigned char	1 byte	–	Set/Get			
		0x31–0x38							

Note: In the “Announcement at status change” column, ○ denotes mandatory processing when the property is implemented.

(1) Operation status (inherited from the device object super class property)

This property indicates whether the function native to this class is operating or not (ON or OFF).

In the node mounting this class, if the function of this class starts operating concurrently with the start of node operation, this property may be implemented at a fixed value of 0x30 (operation status ON).

(2) Sound generation setting

This property indicates the buzzer sound generation setting.

The value 0x41 shall be used when the buzzer is enabled. The value 0x42 shall be used when the buzzer is disabled.

(3) Buzzer sound type

This property indicates the types of buzzer sound.

The relationship between specific values and sound types is not stipulated.

3. 4 Cooking/Household-related Device Class Group

This section specifies detailed codes and properties for each ECHONET object belonging to the cooking/household-related device class group (class group specification code X1 = 0x03). Table 3-4 shows a list of classes specified in detail in this section. In the requirements of classes, “Mandatory” means that the device mounting each class must mount a combination of its property and service.

Table 3-4 List of Objects of Cooking/Household-related Device Class Group

Class group code	Class code	Class name	Detailed requirements	Remarks
0x03	0x00 to 0xAF	For future reserved		
	0xB0	Coffee machine		
	0xB1	Coffee mill		
	0xB2	Electric hot water pot (Electric thermos)	○	
	0xB3	Electric stove		
	0xB4	Toaster		
	0xB5	Juicer, food mixer		
	0xB6	Food processor		
	0xB7	Refrigerator	○	
	0xB8	Combination microwave oven(Electronic oven)	○	
	0xB9	Cooking heater	○	
	0xBA	Oven		
	0xBB	Rice cooker	○	
	0xBC	Electronic jar		
	0xBD	Dish washer		
	0xBE	Dish dryer		
	0xBF	Electric rice card cooker		
	0xC0	Keep-warm machine		
	0xC1	Rice mill		
	0xC2	Automatic bread cooker		
0xC3	Slow cooker			
0xC4	Electric pickles cooker			
0xC5	Washing machine	○		
0xC6	Clothes dryer	○		
0xC7	Electric iron			

	0xC8	Trouser press		
	0xC9	Futon dryer		
	0xCA	Small article, shoes dryer		
	0xCB	Electric vacuum cleaner (including central vacuum cleaner)		
	0xCC	Disposer		
	0xCD	Electric mosquito catcher		
	0xCE	Commercial show case		
	0xCF	Commercial refrigerator		
	0xD0	Commercial hot case		
	0xD1	Commercial fryer		
	0xD2	Commercial microwave oven		
	0xD3	Washer and dryer	○	
	0xD4 to 0xFF	For future reserved		

Note: ○ indicates a detail is explained including a property structure in APPENDIX.

3. 4. 1 Requirements for electric hot water pot (Electric thermos)

Class group code : 0x03

Class code : 0xB2

Instance code : 0x01–0x7F (0x00: All-instance specification code)

Property name	EPC	Contents of property	Data type	Data size	Unit	Access rule	Mandatory	Announcement at status change	Remark
		Value range (decimal notation)							
Operation status	0x80	This property indicates the ON/OFF status.	unsigned char	1 byte	—	Set		○	
		ON=0x30, OFF=0x31				Get			
Cover open/close status	0xB0	Cover open/close status	unsigned char	1 byte	—	Get			
		Cover open = 0x41, cover closed = 0x42							
No-water warning	0xB1	Notifies that electric hot water pot is emptied of water.	unsigned char	1 byte	—	Get		○	
		No-water condition found = 0x41 No-water condition not found = 0x40							
Boil-up setting	0xB2	Boil-up setting	unsigned char	1 byte	—	Set/Get			
		Boil-up start = 0x41 Boil-up stop/warmer = 0x42							
Boil-up/warmer mode setting	0xE0	This property indicates citric acid cleaning, normal warmer or power-saving warmer mode.	unsigned char	1 byte	—	Set/Get			
		Citric acid cleaning = 0x41, normal warmer = 0x42, power-saving warmer = 0x43							
Set value of warmer temperature	0xE1	This property indicates set value of warmer temperature in °C.	unsigned char	1 byte	°C	Set/Get			
		0x00–0x64 (0–100)							
Hot water discharge status	0xE2	Hot water discharge status	unsigned char	1 byte	—	Get		○	
		Hot water discharged = 0x41, hot water not discharged = 0x42							
Lock status	0xE3	Hot water discharge lock status	unsigned char	1 byte	—	Get			
		Locked = 0x41, unlocked = 0x42							

Note: In the “Announcement at status change” column, ○ denotes mandatory processing when the property is implemented.

(1) Operation status (inherited from the device object super class property)

This property indicates whether the function native to this class is operating or not (ON or OFF). In the node mounting this class, if the function of this class starts operating concurrently with the start of node operation, this property may be implemented at a fixed value of 0x30 (operation status ON).

(2) Cover open/close status

This property indicates whether the electric hot water pot (electric thermos) cover is

open or closed. The value 0x41 shall be used to indicate that the cover is open. The value 0x42 shall be used to indicate that the cover is closed.

(3) No-water warning

The value of this property shall change from 0x40 to 0x41 when the electric hot water pot is emptied of water. When the electric hot water pot is charged with cold or hot water, the property value shall change from 0x41 to 0x40.

(4) Boil-up setting

Sets the water heating start and water heating stop/warmer states. These two states correspond to the property values 0x41 and 0x42, respectively. The value of this property shall automatically change to 0x42 when the electric hot water pot terminates its water heating operation.

(5) Boil-up/warmer mode setting

This property indicates the water heating/warmer mode setting for the electric hot water pot (citric acid cleaning, normal warmer, or power-saving warmer mode). The property values 0x41, 0x42, and 0x43 correspond to these operation modes, respectively. For the property values to be implemented, only the property values related to the functions incorporated in the actual device mounting this class need be implemented.

(6) Set value of warmer temperature

This property indicates the set value of warmer temperature in °C.
The property value range shall be 0x00 to 0x64 (0 to 100°C).

(7) Hot water discharge status

This property indicates the hot water discharge status: hot water discharged = 0x41 or hot water not discharged = 0x42. More specifically, the value 0x41 indicates that hot water is being discharged because a hot water discharge procedure is performed by a human, whereas the value 0x42 indicates that no hot water is being discharged.

(8) Lock status

This property indicates whether or not the electric hot water pot (electric thermos) is locked. The value 0x41 indicates that the electric hot water pot is locked. The value 0x42 indicates that the lock is released.

3. 4. 2 Requirements for refrigerator class

Class group code : 0x03

Class code : 0xB7

Instance code : 0x01–0x7F (0x00: All-instance specification code)

Property name	EPC	Contents of property	Data type	Data size	Unit	Access rule	Mandatory	Announcement at status change	Remark
		Value range (decimal notation)							
Operation status	0x80	This property indicates the ON/OFF status.	unsigned char	1 byte	—	Set		○	
		ON=0x30, OFF=0x31				Get			
Door open/close status	0xB0	Door open/close status	unsigned char	1 byte	–	Get	Ⓜ		
		Door open = 0x41, Door close = 0x42							
Door open warning	0xB1	Door open warning status	unsigned char	1 byte	–	Get		○	
		Door open warning found = 0x41 Door open warning not found = 0x42							
Refrigerator compartment door status	0xB2	Used to acquire the status (i.e. open or closed) of the refrigerator compartment door.	unsigned char	1 byte	–	Get			
		Open = 0x41, closed = 0x42							
Freezer compartment door status	0xB3	Used to acquire the status (i.e. open or closed) of the freezer compartment door.	unsigned char	1 byte	–	Get			
		Open = 0x41, closed = 0x42							
Ice compartment door status	0xB4	Used to acquire the status (i.e. open or closed) of the ice compartment door.	unsigned char	1 byte	–	Get			
		Open = 0x41, closed = 0x42							
Vegetable compartment door status	0xB5	Used to acquire the status (i.e. open or closed) of the vegetable compartment door.	unsigned char	1 byte	–	Get			
		Open = 0x41, closed = 0x42							
Multi-refrigerating mode compartment door	0xB6	Used to acquire the status (i.e. open or closed) of the multi-refrigerating mode compartment door.	unsigned char	1 byte	–	Get			
		Open = 0x41, closed = 0x42							
Maximum allowable temperature setting level	0xE0	Used to acquire the maximum allowable temperature setting levels for the individual compartments of the refrigerator.	unsigned char × 8	8 bytes	–	Get			
		First byte: Refrigerator compartment Second byte: Freezer compartment Third byte: subzero-fresh compartment Fourth byte: Vegetable compartment Fifth byte: Multi-refrigerating mode compartment Sixth to eighth bytes: Reserved for future use. 0x01–0xFF (Level 1–255) 0x00 = no compartment							

Refrigerator compartment temperature setting	0xE2	Used to specify the refrigerator compartment temperature in °C, and to acquire the current setting.	signed char	1 byte	°C	Set/Get			
		0x81-0x7E (-127-126°C)							
Freezer compartment temperature setting	0xE3	Used to specify the freezer compartment temperature in °C, and to acquire the current setting.	signed char	1 byte	°C	Set/Get			
		0x81-0x7E (-127-126°C)							
Ice temperature setting	0xE4	Used to specify the ice compartment temperature in °C, and to acquire the current setting.	signed char	1 byte	°C	Set/Get			
		0x81-0x7E (-127-126°C)							
Vegetable compartment temperature setting	0xE5	Used to specify the vegetable compartment temperature in °C, and to acquire the current setting.	signed char	1 byte	°C	Set/Get			
		0x81-0x7E (-127-126°C)							
Multi-refrigerating mode compartment temperature setting	0xE6	Used to specify the multi-refrigerating mode compartment temperature in °C, and to acquire the current setting.	signed char	1 byte	°C	Set/Get			
		0x81-0x7E (-127-126°C)							
Refrigerator compartment temperature level setting	0xE9	Used to specify the refrigerator compartment temperature by selecting a level from among the predefined levels, and to acquire the current setting.	unsigned char	1 byte	—	Set/Get			
		0x01 to maximum allowable temperature setting level (highest to lowest temperature)							
Freezer compartment temperature level setting	0xEA	Used to specify the freezer compartment temperature by selecting a level from among the predefined levels, and to acquire the current setting.	unsigned char	1 byte	—	Set/Get			
		0x01 to maximum allowable temperature setting level (highest to lowest temperature)							
ice compartment temperature level setting	0xEB	Used to specify ice compartment temperature by selecting a level from among the predefined levels, and to acquire the current setting.	unsigned char	1 byte	—	Set/Get			
		0x01 to maximum allowable temperature setting level (highest to lowest temperature)							
Vegetable compartment temperature level setting	0xEC	Used to specify the vegetable compartment temperature by selecting a level from among the predefined levels, and to acquire the current setting.	unsigned char	1 byte	—	Set/Get			
		0x01 to maximum allowable temperature setting level (highest to lowest temperature)							
Multi-refrigerating mode compartment temperature level setting	0xED	Used to specify the multi-refrigerating mode compartment temperature by selecting a level from among the predefined levels, and to acquire the current setting.	unsigned char	1 byte	—	Set/Get			

		0x01 to maximum allowable temperature setting level (highest to lowest temperature)							
Measured refrigerator compartment temperature	0xD1	Used to acquire the measured refrigerator compartment temperature (°C).	signed char	1 byte	°C	Get			
		0x81–0x7E (-127–126°C)							
Measured freezer compartment temperature	0xD2	Used to acquire the measured freezer compartment temperature (°C).	signed char	1 byte	°C	Get			
		0x81–0x7E (-127–126°C)							
Measured subzero-fresh compartment temperature	0xD3	Used to acquire the measured meat and fish compartment temperature (°C).	signed char	1 byte	°C	Get			
		0x81–0x7E (-127–126°C)							
Measured vegetable compartment temperature	0xD4	Used to acquire the measured vegetable compartment temperature (°C).	signed char	1 byte	°C	Get			
		0x81–0x7E (-127–126°C)							
Measured multi-refrigerating mode compartment temperature	0xD5	Used to acquire the measured multi-refrigerating mode compartment temperature (°C).	signed char	1 byte	°C	Get			
		0x81–0x7E (-127–126°C)							
Compressor rotation speed	0xD8	Used to acquire the rotation speed of the compressor. The rotation speed is expressed in terms of a level.	unsigned char	2 bytes	—	Get			
		First byte: Maximum rotation speed L (0x01–0xFF (1–255)) Second byte: Rotation speed of the actual compressor: 0x00 to L (zero speed to highest speed)							
Measured electric current consumption	0xDA	Used to acquire the measured electric current consumption.	unsigned char	2 bytes	0.1A	Get			
		0x0000–0xFFFF (0–6553.3A)							
Rated power consumption	0xDC	Used to acquire the rated power consumption.	unsigned char	2 bytes	W	Get			
		0x0000–0xFFFF (0–65533W)							
Quick freeze function setting	0xA0	Used to specify whether or not to use the “Quick freeze” function of the refrigerator, and to acquire the current setting.	unsigned char	1 byte	—	Set/Get			
		“Normal operation” mode: 0x41 “Quick freeze” mode: 0x42 “Standby for fast freezing” mode: 0x43							
Quick refrigeration function setting	0xA1	Used to specify whether or not to use the “quick refrigeration” function of the refrigerator, and to acquire the current setting.	unsigned char	1 byte	—	Set/Get			
		“Normal operation” mode: 0x41 “Quick refrigeration” mode: 0x42 “Standby for quick refrigeration” mode: 0x43							

Icemaker setting	0xA4	Used to specify whether or not to enable the automatic icemaker of the refrigerator, and to acquire the current setting.	unsigned char	1 byte	—	Set/Get			
		“Enable icemaker” option: 0x41 “Disable icemaker” option: 0x42 “Temporarily disable icemaker” option: 0x43							
Icemaker operation status	0xA5	Used to acquire the status of the automatic icemaker of the refrigerator.	unsigned char	1 byte	—	Get			
		“Ice-making in progress” state: 0x41 “Ice-making stopped” state: 0x42							
Icemaker tank status	0xA6	Used to acquire the status of the tank of the automatic icemaker of the refrigerator in terms of whether it contains water or not.	unsigned char	1 byte	—	Get			
		Icemaker tank contains water: 0x41 There is no water left in the icemaker tank or the icemaker tank has not been positioned correctly in the refrigerator: 0x42							
Refrigerator compartment humidification function setting	0xA8	Used to specify whether or not to use the refrigerator compartment humidification function, and to acquire the current setting.	unsigned char	1 byte	—	Set/Get			
		ON = 0x41 OFF = 0x42							
Vegetable compartment humidification function setting	0xA9	Used to specify whether or not to use the vegetable compartment humidification function, and to acquire the current setting.	unsigned char	1 byte	—	Set/Get			
		ON = 0x41 OFF = 0x42							
Deodorization function setting	0xAD	Used to specify whether or not to use the deodorization function of the refrigerator, and to acquire the current setting.	unsigned char	1 byte	—	Set/Get			
		ON = 0x41 OFF = 0x42							

Note: In the “Announcement at status change” column, ○ denotes mandatory processing when the property is implemented.

(1) Operation status (inherited from the device object super class property)

Operation status property specifies the operation status (i.e. ON or OFF) of the refrigerator and freezer, and to acquire the current setting. In cases where the refrigerator and freezer belong to a node in which the “refrigerator and freezer” class is implemented and the refrigerator and freezer start operating as soon as the node starts up, 0x30 may be implemented as the fixed value.

(2) Door open/close status

Door open/close status property specifies the status (i.e. open or closed) of the door.

0x41 and 0x42 shall be used for the “open” and “closed” states, respectively. In cases where the refrigerator has two or more doors, 0x42 shall be used when any of the doors are open. For the purposes of this paragraph, the term “door” shall refer to both any door and any drawer.

(3) Door open warning

Door open warning property specifies the information as to whether or not the “door open” alarm has gone off. 0x41 and 0x42 shall be used for the “alarm activated” and “alarm not activated” states, respectively.

(4) Refrigerator compartment door status

Refrigerator compartment door status property specifies the status (i.e. open or closed) of the refrigerator compartment door. 0x41 and 0x42 shall be used for the “open” and “closed” states, respectively. In cases where the refrigerator compartment has two or more doors, 0x42 shall be used when any of the doors are open. For the purposes of this paragraph, the term “door” shall refer to both any door and any drawer.

(5) Freezer compartment door status

Freezer compartment door status property specifies the status (i.e. open or closed) of the freezer compartment door. 0x41 and 0x42 shall be used for the “open” and “closed” states, respectively. In cases where the freezer compartment has two or more doors, 0x42 shall be used when any of the doors are open. For the purposes of this paragraph, the term “door” shall refer to both any door and any drawer.

(6) Ice compartment door status

Ice compartment door status property specifies the status (i.e. open or closed) of the ice compartment door. 0x41 and 0x42 shall be used for the “open” and “closed” states, respectively. In cases where the ice compartment has two or more doors, 0x42 shall be used when any of the doors are open. For the purposes of this paragraph, the term “door” shall refer to both any door and any drawer.

(7) Vegetable compartment door status

Vegetable compartment door status property specifies the status (i.e. open or closed) of the vegetable compartment door. 0x41 and 0x42 shall be used for the “open” and “closed” states, respectively. In cases where the vegetable compartment has two or more doors, 0x42 shall be used when any of the doors are open. For the purposes of this paragraph, the term “door” shall refer to both any door and any drawer.

(8) Multi-refrigerating mode compartment door status

Multi-refrigerating mode compartment door status property specifies the status (i.e. open or closed) of the multi-refrigerating mode compartment door. 0x41 and 0x42 shall be used for the “open” and “closed” states, respectively. In cases where the multi-refrigerating mode compartment has two or more doors, 0x42 shall be used when any of the doors are open. For the purposes of this paragraph, the term “door” shall refer to both any door and any drawer.

(9) Maximum allowable temperature setting level

Maximum allowable temperature setting level property specifies the maximum allowable temperature setting levels for the individual compartments of the refrigerator. The data size shall be 8 bytes, and the maximum allowable temperature setting level for each compartment shall be indicated using one byte (255 levels (0x01 to 0xFF)). The first to fifth bytes shall be used for the refrigerator, freezer, meat and fish, vegetable and multi-refrigerating mode compartments, respectively. The sixth to eighth bytes are reserved for future use. When the refrigerator does not have one or more of the five types of compartments, 0x00 shall be used for the types of compartments the refrigerator is not equipped with.

(10) Refrigerator compartment temperature setting

Refrigerator compartment temperature setting property specifies the refrigerator compartment temperature in °C, and to acquire the current setting. The property value range shall be 0x81 to 0x7E (-127 to 126°C). When the property value of the actual piece of equipment is higher than the upper limit of the property value range, the overflow code 0x7F shall be used. When the property value is lower than the lower limit of the property value range, the underflow code 0x80 shall be used. It is only required to implement the property values that are supported by the actual piece of equipment in which this class is implemented. In cases where both the “refrigerator compartment temperature setting” property and the “refrigerator compartment temperature level setting” property (EPC = 0xE9) are implemented, the property values shall be correlated.

(11) Freezer compartment temperature setting

Freezer compartment temperature setting property specifies the freezer compartment temperature in °C, and to acquire the current setting. The property value range shall be 0x81 to 0x7E (-127 to 126°C). When the property value of the actual piece of equipment is higher than the upper limit of the property value range, the overflow code 0x7F shall be used. When the property value is lower than the lower limit of the property value range, the underflow code 0x80 shall be used. It is only required to implement the property values that are supported by the actual piece of equipment in which this class is implemented. In cases where both the “freezer compartment temperature setting” property and the “freezer compartment temperature level

setting” property (EPC = 0xEA) are implemented, the property values shall be correlated.

(12) Ice compartment temperature setting

Ice compartment temperature setting property specifies the ice compartment temperature in °C, and to acquire the current setting. The property value range shall be 0x81 to 0x7E (-127 to 126°C). When the property value of the actual piece of equipment is higher than the upper limit of the property value range, the overflow code 0x7F shall be used. When the property value is lower than the lower limit of the property value range, the underflow code 0x80 shall be used. It is only required to implement the property values that are supported by the actual piece of equipment in which this class is implemented. In cases where both the “ice compartment temperature setting” property and the “ice compartment temperature level setting” property (EPC = 0xEB) are implemented, the property values shall be correlated.

(13) Vegetable compartment temperature setting

Vegetable compartment temperature setting property specifies the vegetable compartment temperature in °C, and to acquire the current setting. The property value range shall be 0x81 to 0x7E (-127 to 126°C). When the property value of the actual piece of equipment is higher than the upper limit of the property value range, the overflow code 0x7F shall be used. When the property value is lower than the lower limit of the property value range, the underflow code 0x80 shall be used. It is only required to implement the property values that are supported by the actual piece of equipment in which this class is implemented. In cases where both the “vegetable compartment temperature setting” property and the “vegetable compartment temperature level setting” property (EPC = 0xEC) are implemented, the property values shall be correlated.

(14) Multi-refrigerating mode compartment temperature setting

Multi-refrigerating mode compartment temperature setting property specifies the multi-refrigerating mode compartment temperature in °C, and to acquire the current setting. The property value range shall be 0x81 to 0x7E (-127 to 126°C). When the property value of the actual piece of equipment is higher than the upper limit of the property value range, the overflow code 0x7F shall be used. When the property value is lower than the lower limit of the property value range, the underflow code 0x80 shall be used. It is only required to implement the property values that are supported by the actual piece of equipment in which this class is implemented. In cases where both the “multi-refrigerating mode compartment temperature setting” property and the “multi-refrigerating mode compartment temperature level setting” property (EPC = 0xED) are implemented, the property values shall be correlated.

(15) Refrigerator compartment temperature level setting

Refrigerator compartment temperature level setting property specifies the refrigerator compartment temperature by selecting a level from among the predefined levels, and to acquire the current setting. The maximum allowable temperature setting level shall be acquired with the “maximum allowable temperature setting level” property (EPC = 0xE0). The temperature values for the levels may be defined freely, as long as the smallest to largest temperature level values are used for the highest to lowest temperature values, respectively. It is only required to implement the property values that are supported by the actual piece of equipment in which this class is implemented. In cases where both the “refrigerator compartment temperature level setting” property and the “refrigerator compartment temperature setting” property (EPC = 0xE2) are implemented, the property values shall be correlated. Implementation of this property must be accompanied by the implementation of the “maximum allowable temperature setting level” property (0xE0).

(16) Freezer compartment temperature level setting

Freezer compartment temperature level setting property specifies the freezer compartment temperature by selecting a level from among the predefined levels, and to acquire the current setting. The maximum allowable temperature setting level shall be acquired with the “maximum allowable temperature setting level” property (EPC = 0xE0). The temperature values for the levels may be defined freely, as long as the smallest to largest temperature level values are used for the highest to lowest temperature values, respectively. It is only required to implement the property values that are supported by the actual piece of equipment in which this class is implemented. In cases where both the “freezer compartment temperature level setting” property and the “freezer compartment temperature setting” property (EPC = 0xE3) are implemented, the property values shall be correlated. Implementation of this property must be accompanied by the implementation of the “maximum allowable temperature setting level” property (0xE0).

(17) Ice compartment temperature level setting

Ice compartment temperature level setting property specifies the ice compartment temperature by selecting a level from among the predefined levels, and to acquire the current setting. The maximum allowable temperature setting level shall be acquired with the “maximum allowable temperature setting level” property (EPC = 0xE0). The temperature values for the levels may be defined freely, as long as the smallest to largest temperature level values are used for the highest to lowest temperature values, respectively. It is only required to implement the property values that are supported by the actual piece of equipment in which this class is implemented. In cases where both the “ice compartment temperature level setting”

property and the “ice compartment temperature setting” property (EPC = 0xE4) are implemented, the property values shall be correlated. Implementation of this property must be accompanied by the implementation of the “maximum allowable temperature setting level” property (0xE0).

(18) Vegetable compartment temperature level setting

Vegetable compartment temperature level setting property specifies the vegetable compartment temperature by selecting a level from among the predefined levels, and to acquire the current setting. The maximum allowable temperature setting level shall be acquired with the “maximum allowable temperature setting level” property (EPC = 0xE0). The temperature values for the levels may be defined freely, as long as the smallest to largest temperature level values are used for the highest to lowest temperature values, respectively. It is only required to implement the property values that are supported by the actual piece of equipment in which this class is implemented.

In cases where both the “vegetable compartment temperature level setting” property and the “vegetable compartment temperature setting” property (EPC = 0xE5) are implemented, the property values shall be correlated. Implementation of this property must be accompanied by the implementation of the “maximum allowable temperature setting level” property (0xE0).

(19) Multi-refrigerating mode compartment temperature level setting

Multi-refrigerating mode compartment temperature level setting property specifies the multi-refrigerating mode compartment temperature by selecting a level from among the predefined levels, and to acquire the current setting. The maximum allowable temperature setting level shall be acquired with the “maximum allowable temperature setting level” property (EPC = 0xE0). The temperature values for the levels may be defined freely, as long as the smallest to largest temperature level values are used for the highest to lowest temperature values, respectively. It is only required to implement the property values that are supported by the actual piece of equipment in which this class is implemented.

In cases where both the “multi-refrigerating mode compartment temperature level setting” property and the “multi-refrigerating mode compartment temperature setting” property (EPC = 0xE6) are implemented, the property values shall be correlated. Implementation of this property must be accompanied by the implementation of the “maximum allowable temperature setting level” property (0xE0).

(20) Measured refrigerator compartment temperature

Measured refrigerator compartment temperature property specifies the measured refrigerator compartment temperature (°C). The property value range shall be 0x81

to 0x7E (-127 to 126°C). When the property value of the actual piece of equipment is higher than the upper limit of the property value range, the overflow code 0x7F shall be used. When the property value is lower than the lower limit of the property value range, the underflow code 0x80 shall be used.

(21) Measured freezer compartment temperature

Measured freezer compartment temperature property specifies the measured freezer compartment temperature (°C). The property value range shall be 0x81 to 0x7E (-127 to 126°C). When the property value of the actual piece of equipment is higher than the upper limit of the property value range, the overflow code 0x7F shall be used. When the property value is lower than the lower limit of the property value range, the underflow code 0x80 shall be used.

(22) Measured ice compartment temperature

Measured ice compartment temperature property specifies the measured meat and fish compartment temperature (°C). The property value range shall be 0x81 to 0x7E (-127 to 126°C). When the property value of the actual piece of equipment is higher than the upper limit of the property value range, the overflow code 0x7F shall be used. When the property value is lower than the lower limit of the property value range, the underflow code 0x80 shall be used.

(23) Measured vegetable compartment temperature

Measured vegetable compartment temperature property specifies the measured vegetable compartment temperature (°C). The property value range shall be 0x81 to 0x7E (-127 to 126°C). When the property value of the actual piece of equipment is higher than the upper limit of the property value range, the overflow code 0x7F shall be used. When the property value is lower than the lower limit of the property value range, the underflow code 0x80 shall be used.

(24) Measured multi-refrigerating mode compartment temperature

Measured multi-refrigerating mode compartment temperature property specifies the measured multi-refrigerating mode compartment temperature (°C). The property value range shall be 0x81 to 0x7E (-127 to 126°C). When the property value of the actual piece of equipment is higher than the upper limit of the property value range, the overflow code 0x7F shall be used. When the property value is lower than the lower limit of the property value range, the underflow code 0x80 shall be used.

(25) Compressor rotation speed

Compressor rotation speed property specifies the rotation speed of the compressor. The rotation speed is expressed in terms of levels. The first and second bytes shall

indicate the maximum acquirable rotation speed and the rotation speed of the actual compressor, respectively. The maximum acquirable rotation speed is also expressed in terms of levels. The rotation speed values for the levels may be defined freely, as long as the smallest to largest level values are used for the lowest to highest speed values, respectively, with 0x00 used for zero speed. The property value range shall be as defined by the following equation:

“Value of the first byte” \geq “Value of the second byte”

(26) Measured electric current consumption

Measured electric current consumption property specifies the present measured electric current consumption (expressed in increments of 0.1A) of the refrigerator and freezer. When the measured electric current is alternating current, the effective value shall be indicated. The property value range shall be 0x0000 to 0xFFFD (0 to 6553.3A). When the property value of the actual piece of equipment is higher than the upper limit of the property value range, the overflow code 0xFFFF shall be used. When the property value is lower than the lower limit of the property value range, the underflow code 0xFFFE shall be used.

(27) Rated power consumption

Used to acquire the rated power consumption (W; brochure value). The property value range shall be 0x0000 to 0xFFFD (0 to 65533W).

(28) Quick freeze function setting

Quick freeze function setting property specifies whether or not to use the “quick freeze” function of the refrigerator, and to acquire the current setting. 0x41, 0x42 and 0x43 shall be used for the “normal operation,” “quick freeze” and “standby for quick freezing” modes, respectively. The “standby for quick freezing” mode (0x43) shall mean a mode in which the refrigerator is standing by to shift to the “quick freeze” mode because a defrosting cycle is being performed or a condition must be satisfied before the refrigerator can shift to the “quick freeze” mode (0x42) (the refrigerator will shift to the “quick freeze” mode as soon as the defrosting cycle is completed or the condition is satisfied). The property value will change to 0x41 as soon as the quick freeze cycle is completed. The property value may be ignored when it is 0x43. It is only required to implement the property values that are supported by the actual piece of equipment in which this class is implemented.

(29) Quick refrigeration function setting

Quick refrigeration function setting property specifies whether or not to use the “quick refrigeration” function of the refrigerator, and to acquire the current setting. 0x41, 0x42 and 0x43 shall be used for the “normal operation,” “quick refrigeration”

and “standby for quick refrigeration” modes, respectively. The “standby for quick refrigeration” mode (0x43) shall mean a mode in which the refrigerator is standing by to shift to the “quick refrigeration” mode because a defrosting cycle is being performed or a condition must be satisfied before the refrigerator can shift to the “quick refrigeration” mode (0x42) (the refrigerator will shift to the “quick refrigeration” mode as soon as the defrosting cycle is completed or the condition is satisfied). The property value will change to 0x41 as soon as the quick refrigeration cycle is completed. The property value may be ignored when it is 0x43. It is only required to implement the property values that are supported by the actual piece of equipment in which this class is implemented.

(30) Icemaker setting

Icemaker setting property specifies whether or not to enable the automatic icemaker of the refrigerator, and to acquire the current setting. 0x41, 0x42 and 0x43 shall be used for the “enable icemaker,” “disable icemaker” and “temporarily disable icemaker” options, respectively. The “temporarily disable icemaker” option is used to disable the icemaker temporarily when the user does not want to have the icemaker make ice, such as during the small hours of the night and during a vacation. The condition for a shift back from the “disable icemaker” or “temporarily disable icemaker” option to the “enable icemaker” option shall be equipment-dependent and is not specified in this ECHONET Specification. It is only required to implement the property values that are supported by the actual piece of equipment in which this class is implemented.

(31) Icemaker operation status

Icemaker operation status property specifies the status of the automatic icemaker of the refrigerator. 0x41 and 0x42 shall be used for the “ice-making in progress” and “ice-making stopped” states, respectively.

(32) Icemaker tank status

Icemaker tank status property specifies the status of the tank of the automatic icemaker of the refrigerator in terms of whether it contains water or not. When the icemaker tank contains water, the property value shall be 0x41. When there is no water left in the icemaker tank or when the icemaker tank has not been positioned correctly in the refrigerator, the property value shall be 0x42.

(33) Refrigerator compartment humidification function setting

Refrigerator compartment humidification function setting property specifies whether or not to use the refrigerator compartment humidification function, and to acquire

the current setting. 0x41 and 0x42 shall be used for the “ON” and “OFF” states, respectively.

(34) Vegetable compartment humidification function setting

Vegetable compartment humidification function setting property specifies whether or not to use the vegetable compartment humidification function, and to acquire the current setting. 0x41 and 0x42 shall be used for the “ON” and “OFF” states, respectively.

(35) Deodorization function setting

Deodorization function setting property specifies whether or not to use the deodorization function of the refrigerator, and to acquire the current setting. 0x41 and 0x42 shall be used for the “ON” and “OFF” states, respectively.

3. 4. 3 Requirements for combination microwave oven (electronic oven) class

Class group code : 0x03

Class code : 0xB8

Instance code : 0x01–0x7F (0x00: All-instance specification code)

Property name	EPC	Contents of property	Data type	Data size	Unit	Access rule	Mandatory	Announcement at status change	Remark
		Value range (decimal notation)							
Operation status	0x80	This property indicates the ON/OFF status.	unsigned char	1 byte	—	Set		○	
		ON=0x30, OFF=0x31				Get			
Door open/close status	0xB0	Used to acquire the status (i.e. open or closed) of the door of the combination microwave oven.	unsigned char	1 byte	–	Get			
		Door open = 0x41, door closed = 0x42							
Heating status	0xB1	Used to acquire the status of the combination microwave oven.	unsigned char	1 byte	–	Get			
		Initial state = 0x40 Heating = 0x41 Heating suspended = 0x42 Reporting completion of heating cycle = 0x43 Setting = 0x44 Preheating = 0x45 Preheat temperature maintenance = 0x46 Heating temporarily stopped for manual cooking action = 0x47							
Heating setting	0xB2	Used to specify whether to start, stop or suspend heating, and to acquire the current setting (i.e. current heating status).	unsigned char	1 byte	–	Set/Get			
		Start/restart heating (heating started/restarted) = 0x41 Suspend heating (heating suspended) = 0x42 Stop heating (heating stopped) = 0x43							
Heating mode setting	0xE0	Used to specify the heating mode of the combination microwave oven, and to acquire the current setting (i.e. current mode).	unsigned char	1 byte	–	Set/Get			
		Microwave heating = 0x41 Defrosting = 0x42 Oven = 0x43 Grill = 0x44 Toaster = 0x45 Fermenting = 0x46 Stewing = 0x47 Steaming = 0x48 Two-stage microwave heating = 0x51 No mode specified = 0xFF							

Automatic heating setting	0xE1	Used to specify whether or not to use the combination microwave oven's automatic heating mode, and to acquire the current setting.	unsigned char	1 byte	–	Set/Get			
		Automatic = 0x41 Manual = 0x42 Not specified = 0xFF							
Automatic heating level setting	0xE2	Used to specify, by selecting a level from among the five predefined levels, the level of automatic heating for the option specified by the “automatic heating menu setting” property, and to acquire the current setting.	unsigned cha	1 byte	–	Set/Get			
		0x31–0x35 (lowest to highest) Not specified = 0xFF							
Automatic heating menu setting	0xD0	Used, when the value of the “automatic heating setting” property is 0x41 (= automatic heating), to select an automatic heating cycle, and to acquire the current setting.	unsigned cha	1 byte	–	Set/Get			
		0 to 0xFE: Automatic heating cycle code (See the automatic heating cycle code table in the subsection entitled “Automatic heating menu setting.”) No automatic heating cycle specified = 0xFF							
Oven mode setting	0xD1	Used, when the value of the “heating mode setting” property (EPC = 0xE0) is 0x43 (= oven), to specify the sub-mode to use, and to acquire the current setting.	unsigned cha	1 byte	–	Set/Get			
		Automatic selection mode = 0x40 Convection oven mode = 0x41 Circulation oven mode = 0x42 Hybrid oven mode = 0x43 No sub-mode specified = 0xFF							
Oven preheating setting	0xD5	Used, when the value of the “heating mode setting” property (EPC = 0xE0) is 0x43 (oven), to specify whether or not to preheat the chamber for the selected oven sub-mode, and to acquire the current setting.	unsigned char	1 byte	–	Set/Get			
		With preheating = 0x41 Without preheating = 0x42 Not specified = 0xFF							
Fermenting mode setting	0xD6	Used, when the value of the “heating mode setting” property (EPC = 0xE0) is 0x46 (= fermenting), to specify the sub-mode to use, and to acquire the current setting.	unsigned char	1 byte	–	Set/Get			
		Automatic selection mode = 0x40 Convection fermentation mode = 0x41 Circulation fermentation mode = 0x42 Hybrid fermentation mode = 0x43 Microwave fermentation mode = 0x51 No mode specified = 0xFF							

Chamber temperature setting	0xE3	Used, when the value of the “heating mode setting” property (EPC = 0xE0) is 0x43 (= oven) or 0x46 (= fermenting), to specify the temperature in the chamber in 0.1°C increments, and to acquire the current setting.	signed short	2 bytes	°C	Set/Get			
		0xF554–0x7FFE (-273.2– 3276.6°C) 0x8001: Automatic 0x8002: Not specified							
Food temperature setting	0xE4	Used to specify the as-heated food temperature in 0.1°C increments, and to acquire the current setting.	signed short	2 bytes	°C	Set/Get			
		0xF554–0x7FFE (-273.2–3276.6°C) 0x8002: Not specified							
Heating time setting	0xE5	Used to specify the duration of heating in the HH:MM:SS format, and to acquire the current setting.	unsigned char ×3	3 bytes	—	Set/Get			
		0–0x17: 0–0x3B: 0–0x3B (= 0–23) (= 0–59) (= 0–59)							
Remaining heating time setting	0xE6	Used to specify the time remaining to complete the heating cycle in the HH:MM:SS format, and to acquire the current setting.	unsigned char ×3	3 bytes	—	Set/Get			
		0–0x17: 0–0x3B: 0–0x3B (= 0–23) (= 0–59) (= 0–59)							
Microwave heating power setting	0xE7	Used, when the value of the “heating mode setting” property (EPC = 0xE0) is 0x41 (= microwave heating), 0x42 (= defrosting), 0x47 (= stewing) or 0x48 (= steaming) or when the value of the “heating mode setting” property (EPC = 0xE0) is 0x46 (= fermenting) and the value of the “fermenting mode setting” property (EPC = 0xD6) is 0x51 (= microwave fermentation mode), to specify the microwave heating power in 1W increments, and to acquire the current setting.	unsigned short	2 bytes	1 W	Set/Get			
		0x0000–0xFFFFD (0–65533W)							
Prompt message setting	0xE8	Used, when it is necessary to instruct the combination microwave oven to temporarily stop heating at a point during a heating cycle to allow the user to perform manual reversing, mixing, etc. and display a message to instruct the user on the manual action to be performed, to specify the prompt message to be displayed and the timing of the message (in terms of a percentage of the total duration of the heating cycle that is allowed to elapse (from the start of the heating cycle) before the message is displayed), and to acquire the current settings. Up to 4 messages may be specified.	unsigned char ×2 ×4	8 bytes	—	Set/Get			
		First byte: Prompt message code (See the prompt message code table in the subsection entitled “Prompt message setting.”) Second byte: Timing value (0–0x64) (0–100%)							

“Accessories to combination microwave oven” setting	0xE9	Used to specify, by means of a 2-byte bit map, what accessory or accessories to the combination microwave oven to use, and to acquire the current setting.	unsigned short	2 bytes	—	Set/Get			
		The value contained in a bit in the bit map shall be “1” if the accessory represented by that bit is used and “0” if the accessory represented by that bit is not used (See the bitmap composition table in the subsection entitled ““Accessories to combination microwave oven” setting”).							
Display character string setting	0xEA	Used to input character strings (up to 20 characters) to use on the display of the combination microwave oven.	unsigned short ×20	40 bytes	—	Set			
		Shift-JIS code characters × 20							
Two-stage microwave heating setting (duration)	0xEB	Used, when the value of the “heating mode setting” property (EPC = 0xE0) is 0x51 (two-stage microwave heating), to specify the duration of the first and second microwave heating cycles in the HH:MM:SS format, and to acquire the current setting. Three bytes shall be used for each heating cycle, with the first and second sets of bytes used for the first and second heating cycles, respectively.	unsigned char ×3 ×2	6 bytes	—	Set/Get			
		Duration of first microwave heating cycle (first through third bytes): 0-0x17: 0-0x3B: 0-0x3B (= 0-23): (= 0-59): (= 0-59) Duration of second microwave heating cycle (fourth through sixth bytes): 0-0x17: 0-0x3B: 0-0x3B (= 0-23): (= 0-59): (= 0-59)							
Two-stage microwave heating setting (heating power)	0xEC	Used, when the value of the “heating mode setting” property (EPC = 0xE0) is 0x51 (two-stage microwave heating), to specify the heating power for the first and second microwave heating cycles in 1W increments, and to acquire the current setting. Two bytes shall be used for each heating cycle, with the first and second pairs of bytes used for the first and second heating cycles, respectively.	unsigned short ×2	4 bytes	1 W	Set/Get			
		Heating power for first microwave heating cycle (first and second bytes): 0x0000-0xFFFFD (0-65533W) Heating power for second microwave heating cycle (third and fourth bytes): 0x0000-0xFFFFD (0-65533W)							

Note: In the “Announcement at status change” column, ○ denotes mandatory processing when the property is implemented.

(1) Operation status (inherited from the device object super class property)

Operation status property specifies whether to place the combination microwave oven into the ON state (i.e. a state in which the combination microwave oven is operating in one of its heating modes or is waiting for a user operation using one of

its heating modes) or OFF state, and to acquire the current setting. 0x30 and 0x31 shall be used for the ON and OFF states, respectively. In cases where the combination microwave oven belongs to a node in which the “combination microwave oven” class is implemented and it starts operating in one of its heating modes or is ready to respond to user operation as soon as the node starts up, 0x30 may be implemented as the fixed value.

(2) Door open/close status

Door open/close status property specifies the status (i.e. open or closed) of the door of the combination microwave oven. 0x41 shall be used for the “open” state and 0x42 shall be used for the “closed” state.

(3) Heating status

Heating status property specifies the status of the combination microwave oven. The following property values shall be used:

Initial state (a state in which no setting has been made or the combination microwave oven is not heating anything): 0x40

Heating: 0x41

Heating suspended (a state in which the combination microwave oven is operating but the current heating cycle has been suspended): 0x42

Reporting completion of heating cycle (a state in which the specified heating cycle has been completed and the combination microwave oven is in the process of shifting to the initial state): 0x43

Setting (a state in which the heating mode, heating time, heating temperature, etc. are being set): 0x44

Preheating (a state in which a preheating cycle is being performed for an oven function-based heating cycle): 0x45

Preheat temperature maintenance (a state in which the preheat temperature achieved for an oven function-based heating cycle is being maintained): 0x46

Heating temporarily stopped for manual cooking action (a state in which heating has been temporarily stopped during a heating cycle to allow the user to perform manual reversing, mixing, etc. and a message is displayed to instruct the user on the manual action to be performed): 0x47

This property indicates the current heating status in more detail than the “heating setting” property (Get) (EPC = 0xB2). The relationship between the property values of this property and the property values of the “heating setting” property (Get) are as follows:

This property	Related property
“Heating status” property (Get) (EPC = 0xB1)	“Heating setting” property (Get) (EPC = 0xB2)

Heating: 0x41	Heating started/resumed: 0x41
Preheating: 0x45	
Preheat temperature maintenance: 0x46	
Heating suspended: 0x42	Heating suspended: 0x42
Heating temporarily stopped for manual cooking action: 0x47	
Initial state: 0x40	Heating stopped: 0x43
Reporting completion of heating cycle: 0x43	
Setting: 0x44	

(4) Heating setting

Heating setting property specifies whether to start, stop or suspend heating. 0x41, 0x42 and 0x43 shall be used for the “start/restart heating (heating started/restarted),” “suspend heating (heating suspended)” and “stop heating (heating stopped)” options/states, respectively.

(5) Heating mode setting

Heating mode setting property specifies the heating mode of the combination microwave oven, and to acquire the current setting (i.e. current mode).

The following property values shall be used:

Microwave heating: 0x41

Defrosting (a heating mode that is focused on defrosting frozen foods): 0x42

Oven: 0x43

Grill: 0x44

Toaster: 0x45

Fermenting: 0x46

Stewing (a heating mode that is focused on preparing stew-type dishes): 0x47

Steaming (a heating mode that is focused on preparing steamed dishes): 0x48

Two-stage microwave heating (a mode in which one microwave heating cycle is followed by another microwave heating cycle): 0x51

When no mode is specified, 0xFF shall be used.

It is only required to implement the property values that correspond to the modes supported by the actual piece of equipment in which this class is implemented. For example, if the piece of equipment in which this class is implemented does not have an oven function, it is not necessary to implement the value for the oven mode (0x43).

If a mode is specified by this property when both this property and the “automatic heating setting” property (EPC = 0xE1) have been implemented, the value of the “automatic heating setting” property shall change to 0x42 (manual heating) unless the property already contains 0x42. It is recommended that this property and the

“automatic heating menu setting” property (EPC = 0xD0) be implemented in such a way that the value of the “automatic heating menu setting” property will change to 0xFF (= no menu item specified) when a mode is specified by this property.

(6) Automatic heating setting

Automatic heating setting property specifies whether or not to use the combination microwave oven’s automatic heating mode (i.e. a mode in which the combination microwave oven performs the automatic heating cycle specified by the “automatic heating menu setting” property), and to acquire the current setting. 0x41 and 0x42 shall be used for the “automatic heating” and “manual heating” options/states, respectively. When neither the “automatic heating” nor “manual heating” mode is specified, 0xFF shall be used.

If a mode is specified by the “heating mode setting” property (EPC = 0xE0) when both this property and the “heating mode setting” property have been implemented, the value of this property shall change to 0x42 (manual heating) unless it already contains 0x42.

If an automatic heating cycle is specified by the “automatic heating menu setting” property (EPC = 0xD0) when both this property and the “automatic heating menu setting” property have been implemented, the value of this property shall change to 0x41 (automatic heating) unless it already contains 0x41.

When the following property is set (SET),	The required property value of “Automatic heating setting” (EPC=0xE1) property
If a mode is specified (Set) by the “heating mode setting” property (EPC = 0xE0)	The value of the “automatic heating setting” property (EPC = 0xE1) must be 0x42 (manual heating)
If an automatic heating cycle is specified (Set) by the “automatic heating menu setting” property (EPC = 0xD0)	The value of the “automatic heating setting” property (EPC = 0xE1) must be 0x41 (automatic heating)

(7) Automatic heating level setting

Automatic heating level setting property specifies by selecting a level from among the five predefined levels, the level of automatic heating for the option specified by the “automatic heating menu setting” property, and to acquire the current setting.

The heating temperature values for the 5 levels may be defined freely, as long as 0x31, 0x33 and 0x35 are used for the lowest, standard and highest temperatures, respectively. When no heating level is specified, 0xFF shall be used.

(8) Automatic heating menu setting

When the value of the “automatic heating setting” property is 0x41 (automatic heating), this property is used to select an automatic heating cycle, and to acquire the current setting. The property values specified in the table below shall be used (The property value range shall be 0x00 to 0xFF (0 to 255)). When no automatic heating

cycle is specified, 0xFF shall be used.

Automatic Heating Cycle Codes

Automatic heating cycle code	Name of automatic heating cycle	Description
0x00	Fully automatic	An automatic heating cycle in which the combination microwave oven automatically determines what to do.
0x01	Reheating boiled rice	Reheats boiled rice that has gotten cold in the microwave heating mode.
0x02	Reheating cooked dish	Reheats cooked dishes (other than boiled rice) that have gotten cold in the microwave heating mode.
0x03	Sake	Warms sake in the microwave heating mode.
0x04	Milk	Heats milk in the microwave heating mode.
0x05	Boiling leafy vegetables	Boils leafy vegetables in the microwave heating mode.
0x06	Boiling fruit/flower vegetables	Boils fruit/flower vegetables in the microwave heating mode.
0x07	Boiling root vegetables	Boils root vegetables in the microwave heating mode.
0x08 to 0x1F	Reserved for future use.	
0x20	Defrosting meat	Defrosts frozen meat, etc.
0x21	Defrosting sashimi	Defrosts frozen sashimi, etc.
0x22 to 0x2F	Reserved for future use.	
0x30	Hamburger steaks	Grills hamburger steaks.
0x31	Gratins	Bakes gratins.
0x32	Chawan-mushi	Makes chawan-mushi (steamed savory egg custard with chicken, shrimps and vegetables).
0x33	Cooking rice	Cooks rice.
0x34	Reheating fries	Reheats fries that have gotten cold.
0x35	Fries	Makes fries.
0x36 to 0x5F	Reserved for future use.	
0x60	Sponge cakes	Bakes sponge cakes.
0x61	Chiffon cakes	Bakes chiffon cakes.
0x62	Cookies	Bakes cookies.
0x63	Cream puffs	Bakes cream puffs.
0x64	Rolls	Bakes rolls.
0x65	Toast	Toasts slices of bread.
0x66 to 0x7F	Reserved for future use.	
0x80 to 0xFE	To be defined by the user.	
0xFF	No automatic heating cycle specified.	

It is only required to implement the property values that correspond to the functions supported by the actual piece of equipment in which this class is implemented.

When the actual piece of equipment is capable of performing any of the automatic heating cycles listed above, the corresponding code must be implemented in the piece of equipment.

If an automatic heating cycle is specified by this property when both this property and the “automatic heating setting” property (EPC = 0xE1) have been implemented, the value of the “automatic heating setting” property shall change to 0x41 (automatic heating) unless the “automatic heating setting” property already contains 0x41.

It is recommended that this property and the “heating mode setting” property (EPC = 0xE0) be implemented in such a way that the value of the “heating mode setting” property will change to 0xFF (= no mode specified) when an automatic heating cycle is specified by this property.

(9) Oven mode setting

When the value of the “heating mode setting” property (EPC = 0xE0) is 0x43 (oven), this property is used to specify the sub-mode to use, and to acquire the current setting.

The following property values shall be used:

Convection oven mode (heats the chamber or bakes food by allowing the heated air to convect within the chamber without forcefully circulating it): 0x41

Circulation oven mode (heats the chamber or bakes food by forcefully circulating the heated air within the chamber using a fan, etc.): 0x42

Hybrid oven mode (convection and circulation oven functions are used in combination): 0x43

Automatic selection mode (combination microwave oven automatically determines what to do within the “oven” mode): 0x40

When no sub-mode is specified, 0xFF shall be used.

It is only required to implement the property values that correspond to the modes supported by the actual piece of equipment in which this class is implemented. For example, if the piece of equipment in which this class is implemented does not have a circulation oven function, it is not necessary to implement the value for the circulation oven mode (0x42).

(10) Oven preheating setting

When the value of the “heating mode setting” property (EPC = 0xE0) is 0x43 (oven), this property is used to specify whether or not to preheat the chamber for the selected oven sub-mode, and to acquire the current setting. 0x41 and 0x42 shall be used for the “with preheating” and “without preheating” options, respectively. When no option is specified, 0xFF shall be used. When no option is specified, the mode to be used shall be implementation-dependent.

(11) Fermenting mode setting

When the value of the “heating mode setting” property (EPC = 0xE0) is 0x46

(fermenting), this property is used to specify the sub-mode to use, and to acquire the current setting.

The following property values shall be used:

Convection fermentation mode (heats the chamber and ferments food by allowing the heated air to convect within the chamber without forcefully circulating it): 0x41

Circulation fermentation mode (heats the chamber and ferments food by forcefully circulating the heated air within the chamber using a fan, etc.): 0x42

Hybrid fermentation mode (convection and circulation fermentation functions are used in combination to heat the chamber and ferment food): 0x43

Microwave fermentation mode (ferments food using the microwave heating function): 0x51

Automatic selection mode (combination microwave oven automatically determines what to do within the “fermenting” mode): 0x40

When no sub-mode is specified, 0xFF shall be used.

It is only required to implement the property values that correspond to the modes supported by the actual piece of equipment in which this class is implemented. For example, if the piece of equipment in which this class is implemented does not have a circulation fermentation function, it is not necessary to implement the value for the circulation fermentation mode (0x42).

(12) Chamber temperature setting

When the value of the “heating mode setting” property (EPC = 0xE0) is 0x43 (oven) or 0x46 (fermenting), this property is used to specify the temperature in the chamber in 0.1°C increments, and to acquire the current setting. The property value range shall be 0xF554 to 0x7FFE (-273.2 to 3276.6°C). When the property value of the actual piece of equipment is higher than the upper limit of the property value range, the overflow code 0x7FFF shall be used. When the property value is lower than the lower limit of the property value range, the underflow code 0x8000 shall be used.

When the actual piece of equipment automatically controls the chamber temperature (for example, in its fermenting mode), the property value shall be 0x8001.

When no temperature is specified, 0x8002 shall be used.

When a value is set in this property and the actual piece of equipment in which this class is implemented is not capable of achieving the temperature that corresponds to the property value (because part or all of the value range of the actual piece of equipment is below the lower limit of the property value range), the value to be used shall be implementation-dependent.

(13) Food temperature setting

Food temperature setting property specifies the as-heated food temperature in 0.1°C increments, and to acquire the current setting. The property value range shall be

0xF554 to 0x7FFE (-273.2 to 3276.6°C). When the property value of the actual piece of equipment is higher than the upper limit of the property value range, the overflow code 0x7FFF shall be used. When the property value is lower than the lower limit of the property value range, the underflow code 0x8000 shall be used. When no temperature is specified, 0x8002 shall be used.

When a value is set in this property and the actual piece of equipment in which this class is implemented is not capable of achieving the temperature that corresponds to the property value (because part or all of the value range of the actual piece of equipment is below the lower limit of the property value range), the value to be used shall be implementation-dependent.

In cases where the design is such that setting a value with this property may necessitate a “heating time setting” property (EPC = 0xE5) value change to ensure consistency between property contents, a means shall be provided to automatically make any required change to the content of the “heating time setting” property.

(14) Heating time setting

Heating time setting property specifies the duration of heating in the “hour (0x00 to 0x17 (0 to 23)): minute (0x00 to 0x3B (0 to 59)): second (0x00 to 0x3B (0 to 59))” format, and to acquire the current setting. Three bytes shall be used, with the highest- and lowest-order bytes used for the “hour” and “second” values, respectively. When the heating time is unknown because an automatic heating cycle has been specified by the “automatic heating menu setting” property or for any other reason, 0xFDFDFD shall be used as the property value. The heating time shall be specified before the heating starts.

When no heating time is specified, 0x000000 shall be used.

When a value is set in this property and the actual piece of equipment in which this class is implemented is not capable of achieving the duration that corresponds to the property value (because part or all of the value range of the actual piece of equipment is below the lower limit of the property value range), the value to be used shall be implementation-dependent.

In cases where the design is such that setting a value with this property may necessitate a “food temperature setting” property (EPC = 0xE4) value change to ensure consistency between property contents, a means shall be provided to automatically make any required change to the content of the “food temperature setting” property.

(15) Remaining heating time

Remaining heating time property specifies the time remaining to complete the heating cycle in the “hour (0x00 to 0x17 (0 to 23)): minute (0x00 to 0x3B (0 to 59)): second (0x00 to 0x3B (0 to 59))” format, and to acquire the current setting. Three

bytes shall be used, with the highest- and lowest-order bytes used for the “hour” and “second” values, respectively.

When the remaining heating time is unknown because an automatic heating cycle has been specified by the “automatic heating menu setting” property or for any other reason, 0xFDFDFD shall be used as the property value.

When no remaining heating time is specified, 0x000000 shall be used.

The remaining heating time shall be specified after the heating starts, because the setting of a value in this property means altering the remaining heating time.

(16) Microwave heating power setting

When the value of the “heating mode setting” property (EPC = 0xE0) is 0x41 (microwave heating), 0x42 (defrosting), 0x47 (stewing) or 0x48 (steaming), or when the value of the “heating mode setting” property (EPC = 0xE0) is 0x46 (fermenting) and the value of the “fermenting mode setting” property (EPC = 0xD6) is 0x51 (microwave fermentation mode), this property is used to specify the microwave heating power in 1W increments, and to acquire the current setting.

The property value range shall be 0x0000 to 0xFFFFD (0 to 65533W).

When the property value of the actual piece of equipment is higher than the upper limit of the property value range, the overflow code 0xFFFF shall be used. When the property value is lower than the lower limit of the property value range, the underflow code 0xFFFE shall be used.

When a value is set in this property and the actual piece of equipment is not capable of achieving the microwave heating power that corresponds to the property value, the value to be used shall be implementation-dependent.

When the microwave heating power is not specified, 0x0000 shall be used.

(17) Prompt message setting

When it is necessary to instruct the combination microwave oven to temporarily stop heating at a point during a heating cycle to allow the user to perform manual reversing, mixing, etc. and display a message to instruct the user on the manual action to be performed, this property is used to specify the prompt message to be displayed and the timing of the message (in terms of a percentage of the total duration of the heating cycle that is allowed to elapse (from the start of the heating cycle) before the message is displayed), and to acquire the current settings.

This property shall use four pairs of bytes, with the first and second bytes of each pair used for the prompt message code (0x00 to 0xFF (0 to 255)) and the timing value (0x00 to 0x64 (0 to 100%)), respectively. The pairs of values shall be arranged in the order that the messages will be displayed. The prompt message codes are defined as follows:

Prompt Message Codes

Prompt message code	Instruction
0x00	No instruction
0x01	Please stir the mixture.
0x02	Please stir the mixture using an eggbeater.
0x03	Please stir the mixture gently but thoroughly.
0x04	Please mix the ingredients thoroughly.
0x05	Please reverse foods.
0x06	Please skim the scum.
0x07 to 0x1F	Reserved for future use.
0x20	Please cover with aluminum foil and continue heating.
0x21	Please cover with clear plastic wrap and continue heating.
0x22	Please put the lid on the pot and continue heating.
0x23 to 0x2F	Reserved for future use.
0x30	Please remove the aluminum foil and continue heating.
0x31	Please remove the clear plastic wrap and continue heating.
0x32	Please take the lid off the pot and continue heating.
0x33 to 0x3F	Reserved for future use.
0x40	Please add the appropriate ingredients.
0x41	Please sprinkle salt and pepper.
0x42 to 0x4F	Reserved for future use.
0x50	Preheating completed
0x51 to 0x7F	Reserved for future use.
0x80 to 0xFF	To be defined by the user.

It is only required to implement the property values that correspond to the functions supported by the actual piece of equipment in which this class is implemented.

When the actual piece of equipment is capable of providing any of the messages listed above, the corresponding code must be implemented in the piece of equipment.

Example:

When the total duration of the heating cycle is 10 minutes and the combination microwave oven is to be instructed to display the prompt message “Please reverse foods” (0x05) two minutes (0x14 = 20% of the total duration of the heating cycle) after the heating cycle starts, the content of the property shall be 0x05 14 00 00 00 00 00 00.

(18) “Accessories to combination microwave oven” setting

“Accessories to combination microwave oven” setting property specifies, by means

of a 2-byte bitmap, what accessory or accessories to use for the combination microwave oven, and to acquire the current setting. The value contained in a bit in the bitmap shall be “1” if the accessory represented by that bit is used (in the specified position in cases where the position is specified) and “0” if the accessory represented by that bit is not used.

When Bit 15 contains “1”, it shall mean that the accessories represented by all the other bits (Bit 0 through Bit 14) are used. When Bit 15 contains “0”, it shall mean that one or more accessories selected from those represented by Bit 0 through Bit 14 are used.

The composition of the 2-byte bitmap shall be as follows:

Bit number	Accessory	Explanation
Bit 0	Ceramic turntable	A circular ceramic turntable that is attachable to a rotating lattice, etc.
Bit 1	Glass turntable	A circular glass turntable that is attachable to a rotating lattice, etc.
Bit 2	Metallic turntable	A circular metallic turntable that is attachable to a rotating lattice, etc.
Bit 3	Rotating lattice	A rotating lattice or plate.
Bit 4	Rotating latticed metallic grill	A latticed metallic grill that is attachable to a turntable.
Bit 5	Rectangular ceramic tray (third shelf level [as counted from the lowest shelf level])	A rectangular ceramic tray for use at the third shelf level of the chamber of a combination microwave oven having 3 shelf levels.
Bit 6	Rectangular metallic tray (third shelf level [as counted from the lowest shelf level])	A rectangular metallic tray for use at the third shelf level of the chamber of a combination microwave oven having 3 shelf levels.
Bit 7	Latticed metallic grill (third shelf level [as counted from the lowest shelf level])	A latticed metallic grill that is mountable on a rectangular tray for use at the third shelf level of the chamber of a combination microwave oven having 3 shelf levels.
Bit 8	Rectangular ceramic tray (second shelf level [as counted from the lowest shelf level])	A rectangular ceramic tray for use at the second shelf level of the chamber of a combination microwave oven having 2 or more shelf levels.
Bit 9	Rectangular metallic tray (second shelf level [as counted from the lowest shelf level])	A rectangular metallic tray for use at the second shelf level of the chamber of a combination microwave oven having 2 or more shelf levels.
Bit 10	Latticed metallic grill (second shelf level [as counted from the lowest shelf level])	A latticed metallic grill that is mountable on a rectangular tray for use at the second shelf level of the chamber of a combination microwave oven having 2 or more shelf levels.
Bit 11	Rectangular ceramic tray (first shelf level [lowest shelf level])	A rectangular ceramic tray for use at the lowest shelf level of the chamber of a combination microwave oven.
Bit 12	Rectangular metallic tray (first shelf level [lowest shelf level])	A rectangular metallic tray for use at the lowest shelf level of the chamber of a combination microwave oven.
Bit 13	Latticed metallic grill (first shelf level [lowest shelf level])	A latticed metallic grill that is mountable on a rectangular tray for use at the lowest shelf level of the chamber of a combination microwave oven.
Bit 14	To be defined by the user.	

Bit 15	Accessory selection bit	When Bit 15 contains “1”, it shall mean that the accessories represented by all the other bits (Bit 0 through Bit 14) are used. When Bit 15 contains “0”, it shall mean that one or more accessories selected from the accessories represented by Bit 0 through Bit 14 are used.
--------	-------------------------	--

When none of the accessories is to be used, Bits 0 through Bit 14 shall contain “0” and Bit 15 shall contain “1” (property value = 0x8000).

When no accessory is specified or the accessories selected are unknown, Bits 0 through Bit 14 and Bit 15 shall contain “0” (property value = 0x0000).

It is only required to implement the property values that correspond to the functions supported by the actual piece of equipment in which this class is implemented.

(19) Display character string setting

Display character string setting property specifies to input character strings to use on the display of the combination microwave oven. The shift-JIS code system (1 character = 2 bytes) shall be used. The maximum number of characters shall be 20. The first and succeeding pairs of bytes shall be used for the first and succeeding characters, respectively. When the number of characters to input is less than 20, each pair of bytes after the pair of bytes that contains the last character shall contain the shift-JIS space code (0x8140). For example, when the number of characters is 15, each of the 16th through 20th pairs of bytes shall contain the shift-JIS space code (0x8140).

(20) Two-stage microwave heating setting (duration)

When the value of the “heating mode setting” property (EPC = 0xE0) is 0x51 (two-stage microwave heating), this property is used to specify the duration of the first and second microwave heating cycles in the “hour (0x00 to 0x17 (0 to 23)): minute (0x00 to 0x3B (0 to 59)): second (0x00 to 0x3B (0 to 59))” format, and to acquire the current setting. Three bytes shall be used for each heating cycle, with the first set of bytes (first through third bytes) and second set of bytes (fourth through sixth bytes) used for the first and second heating cycles, respectively, and the highest- and lowest-order bytes of each set of bytes used for the “hour” and “second” values, respectively.

When the duration of the heating cycles for two-stage microwave heating is not specified, the value 0x000000 000000 shall be used.

The durations shall be specified before the two-stage microwave heating starts.

This property is independent of the “heating time setting” property (EPC = 0xE5) and there is no need to correlate the properties.

When a value is set in this property and the actual piece of equipment in which this class is implemented is not capable of achieving the duration that corresponds to the property value (because part or all of the value range of the actual piece of

equipment is below the lower limit of the property value range), the value to be used shall be implementation-dependent.

(21) Two-stage microwave heating setting (heating power)

When the value of the “heating mode setting” property (EPC = 0xE0) is 0x51 (two-stage microwave heating), this property is used to specify the heating power for the first and second microwave heating cycles in 1W increments, and to acquire the current setting. Two bytes shall be used for each heating cycle, with the first pair of bytes (first and second bytes) and second pair of bytes (third and fourth bytes) used for the first and second heating cycles, respectively.

The property value range for each microwave heating cycle shall be 0x0000 to 0xFFFFD (0 to 65533W). When the property value of the actual piece of equipment is higher than the upper limit of the property value range, the overflow code 0xFFFF shall be used. When the property value is lower than the lower limit of the property value range, the underflow code 0xFFFE shall be used.

When a value is set in this property and the actual piece of equipment is not capable of achieving the microwave heating power that corresponds to the property value, the value to be used shall be implementation-dependent.

When the heating power for the heating cycles for two-stage microwave heating is not specified, the value 0x0000 0000 shall be used.

This property is independent of the “microwave heating power setting” property (EPC = 0xE7) and there is no need to correlate the properties.

3. 4. 4 Requirements for cooking heater class

Class group code : 0x03

Class code : 0xB9

Instance code : 0x01–0x7F (0x00: All-instance specification code)

Property name	EPC	Contents of property	Data type	Data size	Unit	Access rule	Mandatory	Announcement at status change	Remark
		Value range (decimal notation)							
Operation status	0x80	This property indicates the ON/OFF status.	unsigned char	1 byte	—	Set		○	
		ON=0x30, OFF=0x31				Get			
Heating status	0xB1	Heating status of the left stove: heating status of the right stove: heating status of the far-side stove: heating status of the roaster.	unsigned char × 4	1 byte × 4	–	Get	○		
		Standing by: 0x40 Operating: 0x41 Temporarily stopped: 0x42 Heating prohibited: 0x50 Unknown: 0xFF							
Heating setting	0xB2	Left stove setting: right stove setting: far-side stove setting: roaster setting	unsigned char	1 byte	–	Set/Get			
		Stop heating: 0x40 Start/resume heating: 0x41 Temporarily stop heating: 0x42 No setting: 0xFF							
“All stop” setting	0xB3	Used to stop the heating on all the left stove, right stove, far-side stove and roaster.	unsigned char	1 byte	–	Set	Ⓜ		
		Stop the heating on all of the left stove, right stove, far-side stove and roaster: 0x40							
Heating power setting	0xE7	Heating power of the left stove: heating power of the right stove: heating power of the far-side stove: heating power of the roaster	unsigned char × 4	2 bytes × 4	W Or Level Or –	Set/Get			
		<ul style="list-style-type: none"> • When the heating powers are specified in terms of output wattage (0–10000W) : 0x0000–0x2710 • When the heating powers are specified in terms of level (17 levels) : 0x3000–0x3010 • When the heating powers are specified in terms of the state of flame: <ul style="list-style-type: none"> Very low flame: 0x4002 Low flame: 0x4004 Medium flame: 0x4006 High flame: 0x4008 High power: 0x400a • No setting: 0xFFFF 							

Property name	EPC	Contents of property	Data type	Data size	Unit	Access rule	Mandatory	Announcement at status change	Remark
		Value range (decimal notation)							
Heating temperature setting	0xE3	Left stove temperature setting: right stove temperature setting: far-side stove temperature setting	unsigned char × 3	1 byte × 3	°C	Set/Get			
		Temperature setting: 0x32-0xFA (50-250°C) No setting: 0xFF							
“Heating modes of stoves” setting	0xE0	Heating mode of the left stove: heating mode of the right stove: heating mode of the far-side stove	unsigned char × 3	1 byte × 3	-	Set/Get			
		Heating power control mode: 0x41 Deep-frying mode (tempura, etc.): 0x42 Water heating mode: 0x43 Rice boiling mode: 0x44 Stir-frying mode: 0x45 No setting: 0xFF							
Relative time settings of OFF timers	0x96	Relative time setting of the left stove OFF timer: relative time setting of the right stove OFF timer: relative time setting of the far-side stove OFF timer: relative time setting of the roaster OFF timer	unsigned char × 3 × 4	1 byte × 3 × 4	-	Set/Get			
		Used to set the relative time settings of the OFF timers (in the HH:MM:SS format), activate the relevant timers and acquire the updated current relative time settings of the OFF timers. (0-0x17 : 0-0x3B: 0-0x3B) × 4 (= 0-23) : (= 0-59): (= 0-59) No setting: 0xFFFFFFFF							
Child lock setting	0xA1	Child lock ON/OFF setting	unsigned char	1 byte	-	Set/Get			
		Child lock OFF: 0x40 Child lock ON: 0x41							
Radiant heater lock setting	0xA2	Radiant heater lock ON/OFF	unsigned char	1 byte	-	Set/Get			
		Radiant heater lock OFF: 0x40 Radiant heater lock ON: 0x41							

Note: In the “Announcement at status change” column, ○ denotes mandatory processing when the property is implemented.

(1) Operation status (The device object super class property is inherited.)

This property indicates whether this object is ready to accept control commands (ON state) or not (OFF state).

The values “0x30” and “0x31” shall be assigned to the ON and OFF states, respectively.

In the case of a node implemented with this class in which this class becomes ready to accept control commands as soon as the node starts operating, this property may be implemented with the property value fixed at “0x30.”

(2) Heating status

A GET on this property acquires the heating statuses of the cooking heater's left stove, right stove, far-side stove and roaster.

Each of the states described below shall be assigned with the indicated value:

“Standing by” state (i.e. a state whereby the cooking heater is not operating): 0x40

“Operating” state: 0x41

“Temporarily stopped” state (i.e. a state whereby the cooking heater is operating but the heating is temporarily stopped): 0x42

“Heating prohibited” state (i.e. a state whereby the cooking heater is prohibited from starting to operate): 0x50

“Unknown” (i.e. it is not clear what state the cooking heater is in.): 0xFF

The heating statuses of the left stove, right stove, far-side stove (the “left stove,” “right stove” and “far-side stove” are the stoves located on the left, right and far sides, respectively, as seen from the front) and roaster shall be indicated in the stated order using 4 bytes. For example, if the status of the left stove is “Operating” and the statuses of the right stove, far-side stove and roaster are “Standing by,” the property value is “0x41404040.”

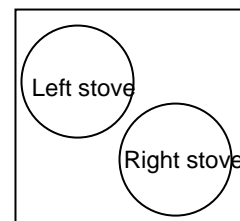
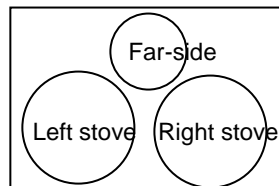
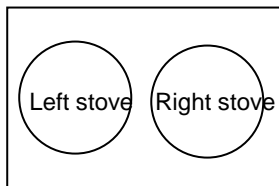

(3) Heating setting

A SET on this property sets the heating operation settings of the cooking heater's left stove, right stove, far-side stove and roaster.

The property values “0x40,” “0x41,” “0x42” and “0xFF” shall be assigned to “Stop heating,” “Start/resume heating,” “Temporarily stop heating” and “No setting,” respectively.

A GET on this property acquires the current settings.

The heating settings of the left stove, right stove, far-side stove (the “left stove,” “right stove” and “far-side stove” are the stoves located on the left, right and far sides, respectively, as seen from the front) and roaster shall be indicated in the stated order using 4 bytes. For example, in the case of a SET to set only the left stove to “Start /resume heating,” the property value is “0x41FFFFFF.” If a stove or the roaster is set to a value other than “0xFF” and then to “0xFF,” the setting of the stove or roaster acquired by a GET on this property will be the value before the stove or roaster was set to “0xFF.” For example, if the property is first set to “0x41FFFFFF” and then to “0xFF41FFFF,” the GET value will be “0x4141FFFF.”

(4) “All stop” setting

A SET on this property stops the heating on all of the cooking heater’s left stove, right stove, far-side stove and roaster.

The property value for stopping the heating on all of the cooking heater’s left stove, right stove, far-side stove and roaster shall be “0x40.”

In the case where a “mobile service” is to be supported, the implementation of this property is mandatory.

(5) Heating power setting

A SET on this property sets the heating power settings of the cooking heater’s stoves and roaster.

In the case where the heating powers are specified in terms of output wattage (in units of 1W), values in the “0x0000–0x2710” (0W–10000W) range shall be used.

In the case where the heating powers are specified in terms of power level, 17 power levels shall be provided and values between 0x3000 and 0x3010 shall be used. The states that correspond to the 17 levels may be defined freely, as long as the values “0x3000” and “0x3010” are assigned to the states in which the heating power is lowest and highest, respectively. The state that corresponds to “0x3000” shall be the state in which the heating power is lowest, and shall not be a state in which the heating power is 0.

In the case where the heating powers are specified in terms of the state of flame, each of the states described below shall be assigned with the indicated value:

Very low flame: 0x4002, Low flame: 0x4004, Medium flame: 0x4006, High flame: 0x4008, High power: 0x400A, No setting: 0xFFFF.

The heating power settings of the left stove, right stove, far-side stove (the “left stove,” “right stove” and “far-side stove” are the stoves located on the left, right and far sides, respectively, as seen from the front) and roaster shall be indicated in the stated order using 8 bytes. For example, the property value in the case where the left stove is set to “High flame,” the right stove is set to “Very low flame” and the heating powers of the far-side stove and roaster are not specified is “0x4008 4002 FFFF FFFF.”

A GET on this property acquires the current heating power settings of the cooking heater. The heating power settings of the cooking heater in the case where the device cannot achieve the values set in this property shall be implementation-dependent.

(6) Heating temperature setting

A SET on this property sets the heating temperature settings of the stoves of the cooking heater (in units of 1°C). A GET on this property acquires the current heating temperature settings of the stoves. The value range shall be 0x32 to 0xFA (50°C to

250°C). The value “0xFF” indicates that the setting is not set. The operation of the actual device in the case where a property value the actual device implemented with this class does not support is specified shall be implementation-dependent.

The heating temperature settings of the left stove, right stove and far-side stove (the “left stove,” “right stove” and “far-side stove” are the stoves located on the left, right and far sides, respectively, as seen from the front) shall be indicated in the stated order using 3 bytes. For example, the property value in the case where the heating temperature setting of the left stove is 180°C and the heating temperature settings of the right and far-side stoves are not set is “0xB4FFFF.”

(7) “Heating modes of stoves” setting

A SET on this property sets the heating modes of the left stove, right stove (the “left” and “right” stoves are the stoves located in the left and right, respectively, as seen from the front) and far-side stove.

A GET on this property acquires the current heating mode settings of the stoves.

Each of the modes described below shall be assigned with the indicated value:

Heating power control mode (i.e. a mode in which the operation is controlled using heating power values that can be set through EPC 0xE7): 0x41

Deep-frying mode (tempura, etc.) (i.e. a mode for cooking deep fries (tempura, etc.) using heating temperature values that can be set through EPC 0xE3): 0x42

Water heating mode: 0x43, Rice boiling mode: 0x44, Stir-frying mode (i.e. a heating mode suitable for cooking stir fries): 0x45

No setting: 0xFF

The heating mode settings of the left stove, right stove and far-side stove (the “left stove,” “right stove” and “far-side stove” are the stoves located on the left, right and far sides, respectively, as seen from the front) shall be indicated in the stated order using 3 bytes. For example, the property value in the case where the heating mode settings of the left and right stoves are “Heating power control mode” and the heating mode setting of the far-side stove is not set is “0x4141FF.”

(8) Relative time settings of OFF timers

A SET on this property sets the relative time settings of the left stove OFF timer, right stove OFF timer, far-side stove OFF timer and roaster OFF timer of the cooking heater.

A GET on this property acquires the updated relative time settings of the stove OFF timers and roaster OFF timer.

The format for the settings shall be “Hour (0x00 to 0x17 (0 to 23)): Minute (0x00 to 0x3B (0 to 59)): Second (0x00 to 0x3B (0 to 59)).”

The relative time settings of the left stove, right stove and far-side stove (the “left stove,” “right stove” and “far-side stove” are the stoves located on the left, right and

far sides, respectively, as seen from the front) OFF timers and the roaster OFF timer shall be indicated in the stated order using 12 bytes. For example, the property value in the case where the relative time setting of the left stove OFF timer is 1 hour and 10 minutes is “0x01 0A 00 FF FF FF FF FF FF FF FF FF.”

The operation of the actual device in the case where a property value the actual device implemented with this class does not support (e.g. a property value that is above the upper limit of the OFF timer setting range for the actual device implemented with this class) is specified is implementation-dependent.

(9) Child lock setting

A SET on this property sets the child lock setting of the cooking heater.

A GET on this property acquires the current child lock setting of the cooking heater.

The property values “0x40” and “0x41” shall be assigned to the child lock OFF (deactivated) and ON states, respectively.

(10) Radiant heater lock setting

A SET on this property sets the radiant heater lock setting of the cooking heater.

A GET on this property acquires the current radiant heater lock setting of the cooking heater.

The property values “0x40” and “0x41” shall be assigned to the radiant heater lock OFF (deactivated) and ON states, respectively.

3. 4. 5 Requirements for rice cooker class

Class group code : 0x03

Class code : 0xBB

Instance code : 0x01–0x7F (0x00: All-instance specification code)

Property name	EPC	Contents of property	Data type	Data size	Unit	Access rule	Mandatory	Announcement at status change	Remark
		Value range (decimal notation)							
Operation status	0x80	This property indicates the ON/OFF status.	unsigned char	1 byte	—	Set	○		
		ON=0x30, OFF=0x31				Get			
Cover open/close status	0xB0	This property indicates whether the cover is open or closed.	unsigned char	1 byte	–	Get			
		Cover open = 0x41, Cover closed = 0x42							
Rice cooking status	0xB1	This property indicates rice cooking status.	unsigned char	1 byte	–	Get	○		
		Stop = 0x41, Preheating = 0x42, Rice cooking = 0x43, Steaming = 0x44, Rice cooking completion = 0x45							
Rice cooking control setting	0xB2	This property indicates rice cooking control setting.	unsigned char	1 byte	–	Set/Get	Ⓜ		
		Rice cooking start/restart = 0x41, Rice cooking suspension = 0x42							
Warmer setting	0xE1	This property indicates whether or not warmer function is enabled.	unsigned char	1 byte	–	Set/Get			
		Warmer enabled = 0x41, Warmer disabled = 0x42							
Inner pot removal status	0xE5	This property indicates whether inner pot is removed or not.	unsigned char	1 byte	–	Get			
		Removed = 0x41, Not removed = 0x42							
Cover removal status	0xE6	This property indicates whether or not cover is removed.	unsigned char	1 byte	–	Get			
		Removed = 0x41, Not removed = 0x42							
Rice cooking reservation setting	0x90	This property indicates whether rice cooking reservation is ON or OFF.	unsigned char	1 byte	–	Set/Get			
		Reservation ON = 0x41, Reservation OFF = 0x42							
Set value of rice cooking reservation setting time	0x91	Timer value (HH:MM)	unsigned char × 2	2 bytes	–	Set/Get			
		0–0x17: 0–0x3B (= 0–23): (= 0–59)							
Set value of rice cooking reservation setting relative time	0x92	Timer value (HH:MM)	unsigned char × 2	2 bytes	–	Set/Get			
		0–0x17: 0–0x3B (= 0–23): (= 0–59)							

Note: In the “Announcement at status change” column, ○ denotes mandatory processing when the property is implemented.

(1) Operation status (inherited from the device object super class property)

This property indicates whether the functions unique to this class are ready to be used (ON) or not (OFF).

In cases where the piece of equipment belongs to a node in which this class is implemented and the functions unique to this class become ready as soon as the node starts up, 0x30 (ON) may be implemented as the fixed value.

(2) Cover open/close status

This property indicates whether the rice cooker cover is open or closed. The value 0x41 shall be used to indicate that the cover is open. The value 0x42 shall be used to indicate that the cover is closed.

(3) Rice cooking status

This property indicates the rice cooking status. The values to be used shall be 0x41 for rice cooking stop, 0x42 for preheating, 0x43 for rice cooking, 0x44 for steaming, and 0x45 for rice cooking completion.

(4) Rice cooking control setting

This property indicates the rice cooking control setting (rice cooking start/restart or rice cooking suspension). The values to be used shall be 0x41 for rice cooking start/restart and 0x42 for rice cooking suspension. In the case where a “home amenity service” is to be supported, the implementation of this property is mandatory.

(5) Warmer setting

This property indicates the warmer setting. The value 0x41 shall be used to indicate that the warmer function is enabled. The value 0x42 shall be used to indicate that the function is disabled.

(6) Inner pot removal status

This property indicates whether or not the inner pot is removed. The value 0x41 shall be used to indicate that the inner pot is removed. The value 0x42 shall be used to indicate that the inner pot is not removed.

(7) Cover removal status

This property indicates whether or not the cover is removed. Here, the expression “the cover is removed” indicates that at least part of a removable cover whose removal is detectable is removed. The value 0x41 shall be used to indicate that the cover is removed. The value 0x42 shall be used to indicate that the cover is not

removed.

(8) Rice cooking reservation setting

This property indicates whether the rice cooking reservation is ON or OFF. The value 0x41 shall be used to indicate that the rice cooking reservation is ON. The value 0x42 shall be used to indicate that the rice cooking reservation is OFF.

(9) Set value of rice cooking reservation setting time

When the “Rice cooking reservation setting” is ON (0x41), this property indicates the time at which rice cooling starts according to the “Rice cooking control setting” or the “Rice cooking status” changes to the “Rice cooking completion” state. The time indication is given in hours and minutes (hour: 0x00 to 0x17 (0 to 23); minute: 0x00 to 0x3B (0 to 59)). The property value shall sequentially indicate the hour and minute, beginning with the high-order byte. The higher- and lower-order bytes shall be used for the “hour” and “minute” values, respectively.

(10) Set value of rice cooking reservation setting relative time

When the “Rice cooking reservation setting” is ON (0x41), this property indicates a time relative to the current time to specify the time at which rice cooling starts according to the “Rice cooking control setting” or the “Rice cooking status” changes to the “Rice cooking completion” state. The data format shall be such that the hour and minute values range from 0x00 to 0x17 (0 to 23) and 0x00 to 0x3B (0 to 59), respectively. The property value shall sequentially indicate the hour and minute, beginning with the high-order byte.

3. 4. 6 Requirements for washing machine class

Class group code: 0x03
Class code : 0xC5
Instance code : 0x01–0x7F (0x00 : All-instance specification code)

Property name	EPC	Contents of property	Data type	Data size	Unit	Access rule	Mandatory	Announcement at status change	Remark
		Value range (decimal notation)							
Operation status	0x80	This property indicates the ON/OFF status.	unsigned char	1 byte	—	Set		○	
		ON=0x30, OFF=0x31				Get			
Door/cover open/close status	0xB0	This property indicates whether the door/cover is open or closed.	unsigned char	1 byte	–	Get			
		Door/cover open = 0x41 Door/cover closed = 0x42							
Washing machine setting	0xB2	Washing machine setting	unsigned char	1 byte	–	Set/Get			
		Start/restart the washing cycle (started/restarted) = 0x41							
		Suspend the washing cycle (suspended) = 0x42							
		Stop the washing cycle (stopped) = 0x43							
Current stage of washing cycle	0xE1	This property indicates the current stage of the washing cycle.	unsigned char	1 byte	–	Get			
		Washing = 0x41, rinsing = 0x42, spin drying = 0x43, suspended = 0x44, washing cycle stopped/completed = 0x45							
Time remaining to complete washing cycle	0xE6	This property indicates the time remaining to complete the current washing cycle in the HH:MM:SS format.	unsigned char × 3	3 bytes	–	Get			
		0–0x17: 0–0x3B: 0–0x3B (= 0–23): (= 0–59): (= 0–59)							
ON timer reservation setting	0x90	Reservation ON/OFF	unsigned char	1 byte	–	Set/Get			
		Reservation ON = 0x41, reservation OFF = 0x42							
ON timer setting	0x91	Timer value (HH:MM)	unsigned char × 2	2 bytes	–	Set/Get			
		0–0x17: 0–0x3B (= 0–23): (= 0–59)							
Relative time-based ON timer setting	0x92	Timer value (HH:MM)	unsigned char × 2	2 bytes	–	Set/Get			
		0–0x17: 0–0x3B (= 0–23): (= 0–59)							

Note: In the “Announcement at status change” column, ○ denotes mandatory processing when the property is implemented.

(1) Operation status (inherited from the device object super class property)

This property indicates whether the washing machine is in the ON state (i.e. the

washing machine responds to user operation) or OFF state. 0x30 and 0x31 shall be used for the ON and OFF states, respectively. In cases where the washing machine belongs to a node in which the “washing machine” class is implemented and the washing machine is ready to respond to user operation as soon as the node starts up, 0x30 may be implemented as the fixed value.

(2) Door/cover open/close status

This property indicates whether the door/cover of the washing machine is open or closed. 0x41 shall be used for the “open” state and 0x42 shall be used for the “closed” state.

(3) Washing machine setting

Specifies whether to start/restart, suspend or stop the washing cycle. 0x41, 0x42 and 0x43 shall be used for the “start/restart,” “suspend” and “stop” options, respectively.

(4) Current stage of washing cycle

This property indicates the current stage of the washing cycle (i.e. washing, rinsing, spin drying, suspended or washing cycle completed/stopped). 0x41, 0x42, 0x43, 0x44 and 0x45 shall be used for the “washing,” “rinsing,” “spin drying,” “suspended” and “washing cycle completed/stopped” stages, respectively.

(5) Time remaining to complete washing cycle

This property indicates the time remaining to complete the current washing cycle in the “hour (0x00 to 0x17(0 to 23)): minute (0x00 to 0x3B (0 to 59)): second (0x00 to 0x3B (0 to 59))” format. One byte shall be used for each of the 3 values, with the highest-order byte used for the “hour” value and the lowest-order byte used for the “second” value.

(6) ON timer reservation setting

Specifies whether or not to use the washing cycle reservation function. The property value shall be 0x41(reservation ON) or 0x42(reservation OFF). This property is used in combination with the “ON timer setting” or “relative time-based ON timer setting” property.

(7) ON timer setting

When the “ON timer reservation setting” property value is “ON,” this property indicates, in the “hour (0x00 to 0x17 (0 to 23)): minute (0x00 to 0x3B (0 to 59))” format, the time at which the “washing cycle setting” property value will change to “washing cycle start” or the “current stage of washing cycle” property value will change to “washing cycle completed.” The higher- and lower-order bytes shall be

used for the “hour” and “minute” values, respectively.

(8) Relative time-based ON timer setting

When the “ON timer reservation setting” property value is “ON,” this property indicates, in terms of a relative time (“hour (0x00 to 0x17 (0 to 23)) : minute (0x00 to 0x3B (0 to 59))” format) relative to the current time, the time at which the “washing cycle setting” property value will change to “washing cycle start” or the “current stage of washing cycle” property value will change to “washing cycle completed.” The higher- and lower-order bytes shall be used for the “hour” and “minute” values, respectively.

3. 4. 7 Requirements for clothes dryer class

Class group code : 0x03
 Class code : 0xC6
 Instance code : 0x01- 0x7F (0x00: All-instance specification code)

Property name	EPC	Contents of property	Data type	Data size	Unit	Access rule	Mandatory	Announcement at status change	Remark
		Value range (decimal notation)							
Operation status	0x80	This property indicates the ON/OFF status.	unsigned char	1 byte	—	Set		○	
		ON=0x30, OFF=0x31				Get			
Door/cover open/close status	0xB0	This property indicates the status of the door or cover as to whether it is open or closed.	unsigned char	1 byte	—	Get			
		Door/cover open = 0x41 Door/cover closed = 0x42							
Drying setting	0xB2	Drying setting	unsigned char	1 byte	—	Set/Get			
		Start/restart drying=0x41, Suspend drying=0x42, Stop drying=0x43							
Drying status	0xE1	Drying status	unsigned char	1 byte	—	Get			
		Drying in progress=0x41 Drying suspended=0x42 Drying completed/stopped=0x43							
Remaining drying time	0xE6	This property indicates the remaining drying time in the “HH:MM:SS” format.	unsigned char ×3	3 bytes	—	Get			
		0-0x17: 0-0x3B : 0-0x3B (=0-23):(=0-59):(=0-59)							
ON timer reservation setting	0x90	Reservation ON/OFF	unsigned char	1 byte	—	Set/Get			
		Reservation ON=0x41 Reservation OFF=0x42							
ON timer setting	0x91	Timer value HH:MM	unsigned char ×2	2 bytes	—	Set/Get			
		0-0x17: 0-0x3B (=0-23):(=0-59)							
Relative time-based ON timer setting	0x92	Timer value HH:MM	unsigned char ×2	2 bytes	—	Set/Get			
		0-0x17: 0-0x3B (=0-23):(=0-59)							

Note: In the “Announcement at status change” column, ○ denotes mandatory processing when the property is implemented.

(1) Operation status (a property inherited from the device object super class)

This property indicates whether the clothes dryer is in the ON state (i.e. the clothes dryer responds to user operation) or OFF state. 0x30 and 0x31 shall be used for the ON and OFF states, respectively. In cases where the clothes dryer belongs to a node

in which the “clothes dryer” class is implemented and the clothes dryer is ready to respond to user operation as soon as the node starts up, 0x30 may be implemented as the fixed value.

(2) Door/cover open/close status

This property indicates whether the door or cover of the clothes dryer is open or closed.

0x41 shall be used for the “open” state and 0x42 shall be used for the “closed” state.

(3) Drying setting

Specifies what the clothes dryer is instructed to do (start/restart drying=0x41, suspend drying=0x42, stop drying=0x43).

(4) Drying status

This property indicates the status of the clothes dryer’s drying operation (drying in progress=0x41, drying suspended=0x42, drying completed/stopped=0x43).

(5) Remaining drying time

This property indicates the remaining drying time in the “hour (0x00-0x17(0-23)): minute (0x00-0x3B (0-59)): second (0x00-0x3B (0-59))” format, with the higher-order, intermediate-order and lower-order bytes used for the “hour,” “minute” and “second” values, respectively.

(6) ON timer reservation setting

Specifies whether the reservation function for drying operation is ON or OFF. This property shall be related to the “ON timer setting” or “Relative time-based ON timer setting” property. The property value for “reservation function ON” shall be 0x41 and the property value for “reservation function OFF” shall be 0x42.

(7) ON timer setting

This property indicates, when the setting of the “ON timer reservation setting” property is “ON,” the time at which the setting of the “Drying setting” property becomes “start drying” or the setting of the “Drying status” property becomes “drying completed .” The “hour (0x00 to 0x17 (0 to 23)) : minute (0x00 to 0x3B (0 to 59))” format shall be used, with the higher- and lower-order bytes used for the “hour” and “minute” values, respectively.

(8) Relative time-based ON timer setting

When the setting of the “ON timer reservation setting” property is “ON,” this

property indicates, in terms of a relative time (“hour (0x00 to 0x17 (0 to 23)) : minute (0x00 to 0x3B (0 to 59))” format) relative to the current time, the time at which the setting of the “Drying setting” property becomes “start drying” or the setting of the “Drying status” property becomes “drying completed. The higher- and lower-order bytes shall be used for the “hour” and “minute” values, respectively.

3. 4. 8 Requirements for washer and dryer class

Class group code: 0x03

Class code: 0xD3

Instance code: 0x01–0x7F (0x00 = All-instance specification code)

Property name	EPC	Contents of property		Data type	Data size	Unit	Access rule	Mandatory	Announcement at status change	Remark
		Value range (decimal notation)								
Operation status	0x80	This property indicates the ON/OFF status.		unsigned char	1 byte	—	Set	○		
		ON=0x30, OFF=0x31					Get			
Door/cover open/close status	0xB0	Used to acquire the status of the door/cover (i.e. open or closed).		unsigned char	1 byte	—	Get			
		Door/cover open = 0x41 Door/cover closed = 0x42								
Washer and dryer setting	0xB2	Used to specify whether to start or stop the washing, drying or washing and drying cycle, and to acquire the current status.		unsigned char	1 byte	—	Set/Get			
		Start/restart(ed) or in progress = 0x41 Suspend(ed) = 0x42 Stop(ped) = 0x43								
Washer and dryer cycle setting 1 <small>(Note 1)</small>	0xD0	Used to specify the washer and dryer cycle option(s) to use in the “washing and drying,” “washing” or “drying” mode and to acquire the current setting(s). The value ranges shall be as follows: Washing and drying course: 0x21–0x3F Washing and drying course maker original code: 0x40–0x4F Washing course: 0x61–0x7F Washing course maker original code: 0x80–0x8F Drying course: 0xA1–0xBF Drying course maker original code: 0xC0–0xDF		unsigned char	1 byte	—	Set/Get			Note 1 Note 2

		<p><Washing and drying course> Standard = 0x21, silent = 0x22, heavily soiled clothes = 0x23, hard-to-remove stains = 0x24, presoaking = 0x25, blankets = 0x26, soft = 0x27, dry = 0x28, clean rinsing = 0x29, ironing/business shirts = 0x2A, hang drying = 0x2B, thick clothes = 0x2C, disinfection = 0x2D, oil stains = 0x2E, memory = 0x2F, detergent saving = 0x30, lightly soiled clothes = 0x31, quick wash of small amount of laundry = 0x32 Washing course/maker original course = 0x40–0x4F</p> <p><Washing course> Standard = 0x61, silent = 0x62, heavily soiled clothes = 0x63, hard-to-remove stains = 0x64, presoaking = 0x65, blankets = 0x66, soft = 0x67, dry = 0x68, clean rinsing = 0x69, disinfection = 0x6A, oil stains = 0x6B, memory = 0x6C, detergent saving = 0x6D, lightly soiled clothes = 0x6E, quick wash of small amount of laundry = 0x6F, tank cleaning = 0x7F Washing course/maker original course = 0x80–0x8F</p> <p><Drying course> Standard = 0xA1, blankets = 0xA2, soft = 0xA3, dry = 0xA4, ironing/business shirts = 0xA5, hang drying = 0xA6, thick clothes = 0xA7, disinfection = 0xA8, shrinkage minimization = 0xA9, finishing = 0xAA, stationary drying = 0xAB, user definition of drying time = 0xAC, garment warming = 0xAD, tank drying = 0xBF Drying course/maker original course = 0xC0–0xCF</p>							
Washer and dryer cycle setting 2 ^(Note 1)	0xD1	<p>Used to specify the washer and dryer cycle option(s) to use in the “washing and drying” mode, and to acquire the current setting(s). The drying option(s) to use shall be specified with the “drying cycle setting” property (EPC = 0xD2).</p> <p>Maker original code = 0xE0–0xEF</p>	unsigned char	1 byte	—	Set/Get			Note 1 Note 2
	<p>No washing = 0x20, standard = 0x21, silent = 0x22, heavily soiled clothes = 0x23, hard-to-remove stains = 0x24, presoaking = 0x25, blankets = 0x26, soft = 0x27, dry = 0x28, clean rinsing = 0x29, disinfection = 0x2D, oil stains = 0x2E, memory = 0x2F, detergent saving = 0x30, lightly soiled clothes = 0x31, quick wash of small amount of laundry = 0x32, tank cleaning = 0x3F Maker original course = 0xE0–0xEF</p>								
Drying cycle setting ^(Note1)	0xD2	<p>Used to specify the drying cycle option(s) to use, and to acquire the current setting. For the “washing and drying” mode, the “washer and dryer cycle setting 2” property (EPC = 0xD1) shall be used.</p> <p>Maker original code = 0xE0 to 0xEF</p>	unsigned char	1 byte	—	Set/Get			Note 1 Note 2

		No drying = 0xA0, standard = 0xA1, blankets = 0xA2, soft = 0xA3, dry = 0xA4, ironing/business shirts = 0xA5, hang drying = 0xA6, thick clothes = 0xA7, disinfection = 0xA8, shrinkage minimization = 0xA9, finishing = 0xAA, stationary drying = 0xAB, user definition of drying time = 0xAC, garment warming = 0xAD, heater current limit = 0xAE, tank drying = 0xBF Maker original course = 0xE0 0xEF							
Washer and dryer cycle option list 1	0xD3	Used to acquire a bitmap list of the washer and dryer cycle options that can be specified with the “washer and dryer cycle setting 1” property. When the value contained in the bit for the desired washer and dryer cycle option is “1”, the option can be specified. When the value contained in the bit for the desired washer and dryer cycle option is “0”, the option cannot be specified. For the requirement as to which bit must be used for which option, refer to the detailed explanation.	unsigned char ×12,	12 bytes	—	Get			
Washer and dryer cycle option list 2	0xD4	Used to acquire a bitmap list of the washer and dryer cycle options that can be specified with the “washer and dryer cycle setting 2” property. When the value contained in the bit for the desired washer and dryer cycle option is “1”, the option can be specified. When the value contained in the bit for the desired washer and dryer cycle option is “0”, the option cannot be specified. For the requirement as to which bit must be used for which option, refer to the detailed explanation.	unsigned char ×4,	4 bytes	—	Get			
Washer and dryer cycle option list 3	0xD5	Used to acquire a bitmap list of the drying cycle options that can be specified with the “drying cycle setting” property. When the value contained in the bit for the desired drying cycle option is “1”, the option can be specified. When the value contained in the bit for the desired drying cycle option is “0”, the option cannot be specified. For the requirement as to which bit must be used for which option, refer to the detailed explanation.	unsigned char ×4,	4 bytes	—	Get			
Water flow rate setting	0xD6	Used to specify the water flow rate by selecting a level from among the predefined levels and to acquire the current setting. <Absolute setting> 0x31–0x40 (16 levels) * 0x31 and 0x40 shall be used for the lowest and highest flow rates, respectively. <Relative setting relative to the automatic setting> - Automatic setting 0xFF - Relative setting in the positive direction 0xA0–0xA7: Levels 1–8 - Relative setting in the negative direction 0xC0–0xC7: Levels 1–8	unsigned char	1 byte	—	Set/Get			
“Rotation speed for spin drying”	0xD7	Used to specify the rotation speed for spin drying in r/min. and to acquire the current setting.	unsigned short	2 bytes	—	Set/Get			

setting		<Absolute setting> - 0x0000– 0x0FFF (0–4095 r/min.) <Relative setting relative to the automatic setting> - Automatic setting 0xFFFF - Relative setting in the positive direction 0xA000–0xA7FF (1–2048 r/min.) - Relative setting in the negative direction 0xC000–0xC7FF (1–2048r/min.)							
“Degree of drying” setting	0xD8	Used to specify the degree of drying to achieve by selecting a level from among the 16 predefined levels and to acquire the current setting. <Absolute setting> - 0x31–0x40 (16 levels) * 0x31 and 0x40 shall be used for the lowest and highest levels, respectively. <Relative setting relative to the automatic setting> - Automatic setting 0xFF - Relative setting in the positive direction 0xA0–0xA7: Levels 1–8 - Relative setting in the negative direction 0xC0–0xC7: Levels 1–8	unsigned char	1 byte	—	Set/Get			
Remaining washing time	0xDB	Acquires the remaining washing time in the “HH:MM” format. 0–0xFE : 0–0x3B (=0–254) hours : (=0–59) minutes Remaining time unknown=0xFF : 0xFF	unsigned char ×2	2 bytes	—	Get			
Remaining drying time	0xDC	Acquires the remaining drying time in the “HH:MM” format. 0–0xFE : 0–0x3B (=0–254) hours : (=0–59) minutes Remaining time unknown=0xFF : 0xFF	unsigned char ×2	2 bytes	—	Get			
Elapsed time on the ON timer	0xDF	Used to acquire the time elapsed on the ON timer after the ON timer was activated. 0–0xFF: 0–0x3B (= 0–255): (= 0–59)	unsigned char ×2	2 bytes	Hour minutes	Get			
Presoaking time setting	0xE1	Used to specify the duration of the presoaking process and to acquire the current setting. <Absolute setting> - 0x00–0x17: 0x00–0x3B (= 0–23 hours): (= 0–59 minutes) <Relative setting relative to the automatic setting> - Automatic setting 0xFF: 0xFF - Relative setting in the positive direction 0xA000–0xA03B: 1–60 minutes - Relative setting in the negative direction 0xC000–0xC03B: 1–60 minutes	unsigned char ×2	2 bytes	h,mi n	Set/Get			

Current stage of washer and dryer cycle	0xE2	Used to acquire the current stage of the washer and dryer cycle.	unsigned char	1 byte	-	Get			Note 2
		Washing = 0x41 Rinsing = 0x42 Spin drying = 0x43 Suspended = 0x44 Washing completed = 0x45 Washing/drying (without wrinkling minimization) completed = 0x51 Drying = 0x52 Wrinkling minimization = 0x53 Drying (with wrinkling minimization) completed = 0x54 Standing by to start = 0x61 1st rinsing = 0x71 2nd rinsing = 0x72 3rd rinsing = 0x73 4th rinsing = 0x74 5th rinsing = 0x75 6th rinsing = 0x76 7th rinsing = 0x77 8th rinsing = 0x78 1st spin drying = 0x81 2nd spin drying = 0x82 3rd spin drying = 0x83 4th spin drying = 0x84 5th spin drying = 0x85 6th spin drying = 0x86 7th spin drying = 0x87 8th spin drying = 0x88 Preheat spin drying = 0x91 Unique code defined by the manufacture = 0xE0-0xEF							
Water volume setting 1	0xE3	Used to specify the water volume in liters and to acquire the current setting.	unsigned char	1 byte	liter	Set/Get			
		<Absolute setting> - 0x00-0x7F (0-127 liters) < Relative setting relative to the automatic setting > - Automatic setting 0xFF - Relative setting in the positive direction 0xA0-0xBF: 1-32 liters - Relative setting in the negative direction 0xC0-0xDF (1-32 liters)							
Water volume setting 2	0xE4	Used to specify the water volume by selecting a level from among the predefined levels and to acquire the current setting.	unsigned	1 byte	—	Set/Get			

		<p><Absolute setting> - 0x31–0x40 (16 levels) - 0x31 and 0x40 shall be used for the lowest and highest water levels, respectively. < Relative setting relative to the automatic setting > - Automatic setting 0xFF - Relative setting in the positive direction 0xA0–0xA7: Levels 1–8 - Relative setting in the negative direction 0xC0–0xC7: Levels 1– 8</p>	char						
Washing time setting	0xE5	Used to specify the duration of the washing process and to acquire the current setting.	unsigned char ×2	2 bytes	h,mi n	Set/Get			
		<p><Absolute setting> - 0x00–0x17: 0x00–0x3B (= 0–23 hours): (= 0–59 minutes) < Relative setting relative to the automatic setting > - Automatic setting 0xFF - Relative setting in the positive direction 0xA000–0xA03B: 1–60 minutes Relative setting in the negative direction - 0xC000–0xC03B: 1–60 minutes</p>							
“Number of times of rinsing” setting	0xE6	Used to specify the number of times of rinsing and to acquire the current setting.	unsigned char	1 byte	—	Set/Get			
		<p>0–8 times (0x00–0x08) Automatic = 0xFF</p>							
Rinsing process setting	0xE7	Used to specify the rinsing process(es) to use by means of a bitmap, and to acquire the current setting. Four bits are used to represent each rinsing process as follows: Bits 0 through bit 3: 1st rinsing Bits 4 through bit 7: 2nd rinsing Bits 8 through bit 11: 3rd rinsing Bits 12 through bit 15: 4th rinsing Bits 16 through bit 19: 5th rinsing Bits 20 through bit 23: 6th rinsing Bits 24 through bit 27: 7th rinsing Bits 28 through bit 31: 8th rinsing	unsigned char ×4	4 bytes	—	Set/Get			
		<p>0000: Automatic mode 0001: Rinsing without additional feeding of water from the tap 0010: Rinsing with additional feeding of water from the tap 0011: Shower rinsing</p>							
Spin drying time setting	0xE8	Used to specify the duration of the spin drying process in minutes and to acquire the current setting.	unsigned	1 byte	min	Set/Get			

		<Absolute setting> - 0x00-0x3B (0-59 minutes) < Relative setting relative to the automatic setting > - Automatic setting 0xFF - Relative setting in the positive direction 0xA0-0xBF: 1-32 minutes - Relative setting in the negative direction 0xC0-0xDF: 1-32 minute	char						
Drying time setting	0xE9	Used to specify the duration of the drying process and to acquire the current setting.	unsigned char	2 bytes	h,mi n	Set/Get			
		<Absolute setting> - 0x00-0x17: 0x00-0x3B (= 0-23 hours): (= 0-59 minutes) < Relative setting relative to the automatic setting > - Automatic setting 0xFF: 0xFF - Relative setting in the positive direction 0xA000-0xA03B: 1-60 minutes - Relative setting in the negative direction 0xC000-0xC03B: 1-60 minutes	char ×2						
Warm water setting	0xEA	Used to specify the temperature of laundry water in °C and to acquire the current setting.	unsigned char	1 byte	°C	Set/Get			
		0-100°C (0x00-0x64) Not to use warm water = 0xFE Automatic water temperature setting = 0xFF	char						
Bathtub water recycle setting	0xEB	Used to specify whether or not, and when, to recycle used bathtub water, and acquire the current setting.	unsigned char	1 byte	—	Set/Get			
		Bathtub water not used : 0x40 Washing only : 0x41 Rinsing only (excluding the final rinsing) : 0x42 All rinsing processes : 0x43 Washing + rinsing (excluding the final rinsing) : 0x44 Washing + all rinsing processes : 0x45	char						
Wrinkling minimization setting	0xEC	Used to specify whether or not to use the wrinkling minimization function, and to acquire the current setting.	unsigned char	1 byte	—	Set/Get			
		Wrinkling minimization function ON : 0x41 Wrinkling minimization function OFF : 0x42	char						
Time remaining to complete washer and dryer cycle	0xED	Used to acquire the time remaining to complete the current washer and dryer cycle in the “HH:MM” format.	unsigned char	2byte	—	Get			
		0-0xFE: 0-0x3B (= 0-254 hours): (= 0-59 minutes) Remaining time unknown = 0xFF: 0xFF	char ×2						
Door/cover lock setting	0xEE	Used to specify the state of the door/cover lock during operation and to acquire the current setting.	unsigned char	1 byte	—	Set/Get			

		Locked: 0x41 Unlocked: 0x42	char						
Washer and dryer cycle	0xE F	Used to acquire the current washer and dryer cycle setting. Bytes 1 and 2: This property indicates the available items in a bitmap format. Byte 3: Presoaking With presoaking: 0x41 Without presoaking: 0x42 Bytes 4 and 5: Washing time The value of the "washing time setting" property shall be referenced. Byte 6: Number of times of rinsing The value of the "number of times of rinsing setting" property shall be referenced. Bytes 7 through 10: Rinsing process The value of the "rinsing process setting" property shall be referenced. Byte 11: Spin drying time The value of the "spin drying time setting" property shall be referenced. Bytes 12 and 13: Drying time The value of the "drying time setting" property shall be referenced. Byte 14: Warm water setting The value of the "warm water setting" property shall be referenced. Byte 15: Water volume setting 1 The value of the "water volume setting 1" property shall be referenced. Byte 16: Water volume setting 2 The value of the "water volume setting 2" property shall be referenced. Byte 17: Bathtub water recycle setting The value of the "bathtub water recycle setting" property shall be referenced. Byte 18: Water flow rate setting The value of the "water flow rate setting" property shall be referenced. Bytes 19 and 20: "Rotation speed for spin drying" setting The value of the "rotation speed for spin drying setting" property shall be referenced. Byte 21: "Degree of drying" setting The value of the "degree of drying setting" property shall be referenced. Bytes 22 and 23: Presoaking time setting The value of the "presoaking time setting" property shall be referenced. Byte 24: Wrinkling minimization setting The value of the "wrinkling minimization setting" property shall be referenced.	unsigned Char ×24	24 bytes	—	Get			
ON timer reservation setting	0x90	Used to specify whether or not to use the ON timer-based reservation function, and to acquire the current setting. Reservation ON = 0x41, reservation OFF = 0x42	unsigned char	1 byte	—	Set/Get			
ON timer setting	0x91	Used to specify the time for the time-based reservation function of the ON timer and to acquire the current setting. 0-0x17: 0-0x3B (= 0-23): (= 0-59)	unsigned char ×2	2 bytes	—	Set/Get			

Relative time-based ON timer setting	0x92	Used to specify the relative time for the relative time-based reservation function of the ON timer and to acquire the time remaining for the current reservation.	unsigned char ×2	2 bytes	—	Set/Get			
		0-0xFF: 0-0x3B (= 0-255); (= 0-59)							

Note: In the “Announcement at status change” column, ○ denotes mandatory processing when the property is implemented.

Note 1: The washer and dryer cycle shall be specified either by the “washer and dryer cycle setting 1” property (EPC = 0xD0) or by the “washer and dryer cycle setting 2” property (EPC = 0xD1) combined with the “drying cycle setting” property (EPC = 0xD2). Either the “washer and dryer cycle setting 1” property or the “washer and dryer cycle setting 2” and “drying cycle setting” properties shall be implemented in the actual piece of equipment (the alternative shall not be implemented).

The following properties may be used to make changes or additions to the washer and dryer cycle options specified with the “washer and dryer cycle setting 1” property or with the “washer and dryer cycle setting 2” and “drying cycle setting” properties:

- Presoaking time setting (EPC = 0xE1)
- Water volume setting 1 (EPC = 0xE3)
- Water volume setting 2 (EPC = 0xE4)
- Washing time setting (EPC = 0xE5)
- “Number of times of rinsing” setting (EPC = 0xE6)
- Rinsing process setting (EPC = 0xE7)
- Spin drying time setting (EPC = 0xE8)
- Drying time setting (EPC = 0xE9)
- Warm water setting (EPC = 0xEA)
- Bathtub water recycle setting (EPC = 0xEB)
- Wrinkling minimization setting (EPC = 0xEC)
- Water flow rate setting (EPC = 0xD6)
- “Rotation speed for spin drying” setting (EPC = 0xD7)
- “Degree of drying” setting (EPC = 0xD8)

Note 2: Maker original code shall be used for the property which is not defined as the property of the ECHONET object specification.
 The code in the maker original code shall be set by the individual maker and add/delete/modify of the code shall be done by the individual maker.
 The contents set as the maker original code can be open or not to the public by the individual maker.

(1) Operation status (inherited from the device object super class property)

This property indicates whether the washer and dryer are in the ON state (i.e. the washer and dryer respond to user operation) or OFF state. 0x30 and 0x31 shall be used for the ON and OFF states, respectively. In cases where the washer and dryer belong to a node in which the “washer and dryer” class is implemented and the washer and dryer are ready to respond to user operation as soon as the node starts up, 0x30 may be implemented as the fixed value.

(2) Door/cover open/close status

Door/cover open/close status property specifies the status (i.e. open or closed) of the door/cover. 0x41 shall be used for the “open” state and 0x42 shall be used for the “closed” state.

(3) Washer and dryer setting

Washer and dryer setting property specifies whether to start, stop or suspend the washer and dryer cycle, and to acquire the current operation status. 0x41 shall be used for the “start/restart(ed)” option/state and 0x42 and 0x43 shall be used for “suspend(ed)” and “stop(ped)” options/states, respectively. The relationship between the values of this property (Get) and the values of the “current stage of washer and dryer cycle” property (Get) (EPC = 0xE2) are as shown in the table below.

“Washer and dryer setting” property	“Current stage of washer and dryer cycle” property (EPC = 0xE2)
0x41: Washer and dryer cycle in progress	Other than below
0x42: Washer and dryer cycle suspended	0x44: Suspended
0x43: Washer and dryer cycle stopped	0x45: Washing completed 0x51: Washing completed/drying (without wrinkling minimization) completed 0x54: Drying (with wrinkling minimization) completed 0x61: Standing by to start

(4) Washer and dryer cycle setting 1

Washer and dryer cycle setting 1 property specifies the washer and dryer cycle option(s) to use in the “washing and drying” (washing followed by drying), “washing” (washing only) or “drying” (drying only) mode, and to acquire the current setting(s). The value ranges for the “washing and drying,” “washing” and “drying” modes shall be 0x21 to 0x3F, 0x61 to 0x7F and 0xA1 to 0xBF, respectively. It is only required to implement the property values that correspond to the functions provided by the actual piece of equipment in which this class is implemented. The possible washer and dryer cycle options are explained below for each of the 3 modes.

<Washing and drying>

① Standard (0x21)

The most basic washing and drying cycle of the piece of equipment.

② Silent (0x22)

A washing and drying cycle focused on washing and drying clothes at an operation noise level that is lower than that of the “standard” option.

③ Heavily soiled clothes (0x23)

A washing and drying cycle focused on removing stains from heavily soiled clothes. In cases where two different cycles of this type are available for different levels of soiling, this cycle shall be defined as the one for relatively lightly soiled clothes.

④ Hard-to-remove stains (0x24)

A washing and drying cycle focused on removing stains from heavily soiled clothes. In cases where two different cycles of this type are available for different levels of soiling, this cycle shall be defined as the one for relatively heavily soiled clothes. In cases where only one cycle is available for heavily soiled clothes, it must not be defined as the “hard-to-remove stains” (0x24) option.

⑤ Presoaking (0x25)

A washing and drying cycle that includes a presoaking process performed before the washing process.

⑥ Blankets (0x26)

A washing and drying cycle focused on washing blankets.

⑦ Soft (0x27)

A washing and drying cycle focused on washing delicate clothes (e.g. those that easily lose shape).

⑧ Dry (0x28)

A washing and drying cycle focused on washing clothes with a dry-cleaning symbol or delicate clothes (e.g. those that easily lose shape).

⑨ Clean rinsing (0x29)

A washing and drying cycle focused on thorough rinsing.

⑩ Ironing/business shirts (0x2A)

A washing and drying cycle that leaves the laundry slightly damp to facilitate ironing.

⑪ Hang drying (0x2B)

A washing and drying cycle that leaves the laundry slightly damp to allow for hang drying.

⑫ Thick clothes (0x2C)

A washing and drying cycle focused on drying clothes that do not dry easily.

⑬ Disinfection (0x2D)

- A washing and drying cycle focused on removing bacteria.
- ⑭ Oil stains (0x2E)
A washing and drying cycle focused on removing oil stains.
 - ⑮ Memory (0x2F)
A washing and drying cycle option to perform a washing and drying cycle that has been input into the memory by the user.
 - ⑯ Detergent saving (0x30)
A washing and drying cycle focused on saving detergent.
 - ⑰ Lightly soiled clothes (0x31)
A washing and drying cycle focused on quickly washing lightly soiled clothes.
 - ⑱ Quick wash of small amount of laundry (0x32)
A washing and drying cycle focused on washing a small amount of laundry quickly.
 - ⑲ Washing and drying setting/maker original course (0x40 to 0x4F)
A washing and drying process defined by the maker

<Washing>

- ① Standard (0x61)
The most basic washing cycle of the piece of equipment.
- ② Silent (0x62)
A washing cycle focused on washing clothes at an operation noise level that is lower than that of the “standard” cycle.
- ③ Heavily soiled clothes (0x63)
A washing cycle focused on removing stains from heavily soiled clothes. In cases where two different cycles of this type are available for different levels of soiling, this cycle shall be defined as the one for relatively lightly soiled clothes.
- ④ Hard-to-remove stains (0x64)
A washing cycle focused on removing stains from heavily soiled clothes. In cases where two different cycles of this type are available for different levels of soiling, this cycle shall be defined as the one for relatively heavily soiled clothes. In cases where only one cycle is available for heavily soiled clothes, it must not be defined as the “hard-to-remove stains” (0x64) option.
- ⑤ Presoaking (0x65)
A washing cycle that includes a presoaking process performed before the washing process.
- ⑥ Blankets (0x66)
A washing cycle focused on washing blankets.
- ⑦ Soft (0x67)
A washing cycle focused on washing delicate clothes (e.g. those that easily lose

shape).

- ⑧ Dry (0x68)
A washing cycle focused on washing clothes with a dry-cleaning symbol or delicate clothes (e.g. those that easily lose shape).
- ⑨ Clean rinsing (0x69)
A washing cycle focused on thorough rinsing.
- ⑩ Disinfection (0x6A)
A washing cycle focused on removing bacteria.
- ⑪ Oil stains (0x6B)
A washing cycle focused on removing oil stains.
- ⑫ Memory (0x6C)
A washing cycle option to perform a washing cycle that has been input into the memory by the user.
- ⑬ Detergent saving (0x6D)
A washing cycle focused on saving detergent.
- ⑭ Lightly soiled clothes (0x6E)
A washing cycle focused on quickly washing lightly soiled clothes.
- ⑮ Quick wash of small amount of laundry (0x6F)
A washing cycle focused on washing a small amount of laundry quickly.
- ⑯ Tank cleaning (0x7F)
A cycle used to clean the tank.
- ⑰ Washing setting/maker original course (0x80 to 0x8F)
A washing process defined by the maker

<Drying>

- ① Standard (0xA1)
The most basic drying cycle of the piece of equipment.
- ② Blankets (0xA2)
A drying cycle focused on drying blankets.
- ③ Soft (0xA3)
A drying cycle focused on drying delicate clothes (e.g. those that easily lose shape).
- ④ Dry (0xA4)
A drying cycle focused on drying clothes with a dry-cleaning symbol or delicate clothes (e.g. those that easily lose shape).
- ⑤ Ironing/business shirts (0xA5)
A drying cycle that leaves the laundry slightly damp to facilitate ironing.
- ⑥ Hang drying (0xA6)
A drying cycle that leaves the laundry slightly damp to allow for hang drying.

- ⑦ Thick clothes (0xA7)
A drying cycle focused on drying clothes that do not dry easily.
- ⑧ Disinfection (0xA8)
A drying cycle focused on removing bacteria.
- ⑨ Shrinkage minimization (0xA9)
A drying cycle focused on minimizing shrinkage of clothes.
- ⑩ Finishing (0xAA)
A drying cycle focused on drying partly dried laundry.
- ⑪ Stationary drying (0xAB)
A drying cycle that dries the laundry without rotating the drum or tank.
- ⑫ User definition of drying time (0xAC)
A drying cycle option that allows the user to specify the duration of the drying cycle.
- ⑬ Garment warming (0xAD)
A drying cycle used to warm garments.
- ⑭ Tank drying (0xBF)
A cycle used to dry the tank.
- ⑮ Drying setting/maker original course (0xC0 to 0xCF)
A drying process defined by the maker.

(5) Washer and dryer cycle setting 2

Washer and dryer cycle setting 2 property specifies the washer and dryer cycle option(s) to use in the “washing and drying” (washing followed by drying) mode, and to acquire the current setting(s). This property is used in combination with the “drying cycle setting” property (EPC = 0xD2), which is used to specify the drying cycle option(s) to use in combination with the washer and dryer cycle options specified with this property. It is only required to implement the property values that correspond to the functions provided by the actual piece of equipment in which this class is implemented.

- ① No washing (0x20)
A cycle with no washing process.
- ② Standard (0x21)
The most basic washing and drying cycle of the piece of equipment.
- ③ Silent (0x22)
A washing and drying cycle focused on washing and drying clothes at an operation noise level that is lower than that of the “standard” cycle.
- ④ Heavily soiled clothes (0x23)
A washing and drying cycle focused on removing stains from heavily soiled clothes.

In cases where two different cycles of this type are available for different levels of soiling, this cycle shall be defined as the one for relatively lightly soiled clothes.

⑤ Hard-to-remove stains (0x24)

A washing and drying cycle focused on removing stains from heavily soiled clothes. In cases where two different cycles of this type are available for different levels of soiling, this cycle shall be defined as the one for relatively heavily soiled clothes. In cases where there is only one cycle for heavily soiled clothes, it must not be defined as the “hard-to-remove stains” (0x24) option.

⑥ Presoaking (0x25)

A washing and drying cycle that includes a presoaking process performed before the washing process.

⑦ Blankets (0x26)

A washing and drying cycle focused on washing blankets.

⑧ Soft (0x27)

A washing and drying cycle focused on washing delicate clothes (e.g. those that easily lose shape).

⑨ Dry (0x28)

A washing and drying cycle focused on washing clothes with a dry-cleaning symbol as well as delicate clothes (e.g. those that easily lose shape).

⑩ Clean rinsing (0x29)

A washing and drying cycle focused on thorough rinsing.

⑪ Disinfection (0x2D)

A washing and drying cycle focused on removing bacteria.

⑫ Oil stains (0x2E)

A washing and drying cycle focused on removing oil stains.

⑬ Memory (0x2F)

A washing and drying cycle option to perform a washing cycle that has been input into the memory by the user.

⑭ Detergent saving (0x30)

A washing and drying cycle focused on saving detergent.

⑮ Lightly soiled clothes (0x31)

A washing and drying cycle focused on washing lightly soiled clothes quickly.

⑯ Quick wash of small amount of laundry (0x32)

A washing and drying cycle focused on washing a small amount of laundry quickly.

⑰ Tank cleaning (0x3F)

A cycle used to clean the tank.

⑱ Maker original course (0xE0 to 0xEF)

A washing and drying process defined by the maker.

(6) Drying cycle setting

Used to specify the drying cycle option(s) to use, and to acquire the current setting. This property is used in combination with the “washer and dryer cycle setting 2” property (EPC = 0xD1), which is used to specify the washer and dryer cycle (washing) option(s) to use in combination with the drying cycle option(s) specified with this property.

It is only required to implement the property values that correspond to the functions provided by the actual piece of equipment in which this class is implemented.

- ① No drying (0xA0)
A cycle with no drying process.
- ② Standard (0xA1)
The most basic drying cycle of the piece of equipment.
- ③ Blankets (0xA2)
A drying cycle focused on drying blankets.
- ④ Soft (0xA3)
A drying cycle focused on drying delicate clothes (e.g. those that easily lose shape).
- ⑤ Dry (0xA4)
A drying cycle focused on drying clothes with a dry-cleaning symbol as well as delicate clothes (e.g. those that easily lose shape).
- ⑥ Ironing/business shirts (0xA5)
A drying cycle that leaves the laundry slightly damp to facilitate ironing.
- ⑦ Hang drying (0xA6)
A drying cycle that leaves the laundry slightly damp to allow for hang drying.
- ⑧ Thick clothes (0xA7)
A drying cycle focused on drying clothes that do not dry easily.
- ⑨ Disinfection (0xA8)
A drying cycle focused on removing bacteria.
- ⑩ Shrinkage minimization (0xA9)
A drying cycle focused on minimizing shrinkage of clothes.
- ⑪ Finishing (0xAA)
A drying cycle focused on drying partly dried laundry.
- ⑫ Stationary drying (0xAB)
A drying cycle that dries the laundry without rotating the drum or tank.
- ⑬ User definition of drying time (0xAC)
A drying cycle option that allows the user to specify the duration of the drying cycle.
- ⑭ Garment warming (0xAD)

A cycle used to warm garments.

⑮ Heater current limit (0xAE)

A drying cycle in which a limit is imposed on the amount of electric current supplied to the heater.

⑯ Tank drying (0xBF)

A cycle used to dry the tank.

⑰ Maker original course (0xE0 to 0xEF)

A drying process defined by the maker.

(7) Washer and dryer cycle option list 1

Washer and dryer cycle option list 1 property specifies a bitmap list of the washer and dryer cycle options that can be specified with the “washer and dryer cycle setting 1” property (0xD0) for the actual piece of equipment. If the value contained in a bit shown in the table below is “1”, it means that the option represented by that bit is available. If the value is “0”, it means that the option represented by that bit is not available.

	b7	b6	b5	b4	b3	b2	b1	b0
First byte	0x27	0x26	0x25	0x24	0x23	0x22	0x21	0x20
Second byte	0x2F	0x2E	0x2D	0x2C	0x2B	0x2A	0x29	0x28
Third byte	0x37	0x36	0x35	0x34	0x33	0x32	0x31	0x30
Fourth byte	0x3F	0x3E	0x3D	0x3C	0x3B	0x3A	0x39	0x38
Fifth byte	0x67	0x66	0x65	0x64	0x63	0x62	0x61	0x60
Sixth byte	0x6F	0x6E	0x6D	0x6C	0x6B	0x6A	0x69	0x68
Seventh byte	0x77	0x76	0x75	0x74	0x73	0x72	0x71	0x70
Eighth byte	0x7F	0x7E	0x7D	0x7C	0x7B	0x7A	0x79	0x78
Ninth byte	0xA7	0xA6	0xA5	0xA4	0xA3	0xA2	0xA1	0xA0
Tenth byte	0xAF	0xAE	0xAD	0xAC	0xAB	0xAA	0xA9	0xA8
Eleventh byte	0xB7	0xB6	0xB5	0xB4	0xB3	0xB2	0xB1	0xB0
Twelfth byte	0xBF	0xBE	0xBD	0xBC	0xBB	0xAB	0xB9	0xB8

(8) Washer and dryer cycle option list 2

Washer and dryer cycle option list 2 property specifies a bitmap list of the washer and dryer cycle options that can be specified with the “washer and dryer cycle setting 2” property (0xD1) for the actual piece of equipment. If the value contained in a bit shown in the table below is “1”, it means that the option represented by that bit is available. If the value “0”, it means that the option represented by that bit is not available.

	b7	b6	b5	b4	b3	b2	b1	b0
First byte	0x27	0x26	0x25	0x24	0x23	0x22	0x21	0x20
Second byte	0x2F	0x2E	0x2D	0x2C	0x2B	0x2A	0x29	0x28

Third byte	0x37	036	0x35	0x34	0x33	0x32	0x31	0x30
Fourth byte	0x3F	0x3E	0x3D	0x3C	0x3B	0x3A	0x39	0x38

(9) Washer and dryer cycle option list 3

Washer and dryer cycle option list 3 property specifies a bitmap list of the washer and dryer cycle options that can be specified with the “drying cycle setting” property (0xD2) for the actual piece of equipment. If the value contained in a bit shown in the table below is “1”, it means that the option represented by that bit is available. If the value is “0”, it means that the option represented by that bit is not available.

	b7	b6	b5	b4	b3	b2	b1	b0
First byte	0xA7	0xA6	0xA5	0xA4	0xA3	0xA2	0xA1	0xA0
Second byte	0xAF	0xAE	0xAD	0xAC	0xAB	0xAA	0xA9	0xA8
Third byte	0xB7	0xB6	0xB5	0xB4	0xB3	0xB2	0xB1	0xB0
Fourth byte	0xBF	0xBE	0xBD	0xBC	0xBB	0xAB	0xB9	0xB8

(10) Water flow rate setting

Water flow rate setting property specifies, by selecting a level from among the predefined levels, the water flow rate for the washer and dryer cycle option(s) specified with the “washer and dryer cycle setting 1” property (EPC = 0xD0) or with the “washer and dryer cycle setting 2” property (EPC = 0xD1) and the “drying cycle setting” property (EPC = 0xD2), and to acquire the current setting. Three water flow rate setting modes shall be available: “absolute setting,” “automatic setting” and “relative setting” (relative to the automatic setting). When the actual piece of equipment cannot operate at the level specified with this property, the water flow rate to be used shall be implementation-dependent.

<Absolute setting>

It must be possible to specify the water flow rate by selecting a level from among 16 levels in the 0x31 to 0x40 (lowest to highest) range and acquire the setting.

<Automatic setting; relative setting relative to the automatic setting>

0xFF shall be used for the “automatic setting” mode.

In relative setting in the positive direction, it must be possible to specify the water flow rate by selecting a level from among 8 levels (Level 1 to Level 8) in the 0xA0 to 0xA7 range. In relative setting in the negative direction, it must be possible to specify the water flow rate by selecting a level from among 8 levels (Level 1 to Level 8) in the 0xC0 to 0xC7 range.

(11) “Rotation speed for spin drying” setting

“Rotation speed for spin drying” setting property specifies the rotation speed for spin drying (in r/min.) for the washer and dryer cycle option(s) specified with the “washer and dryer cycle setting 1” property (EPC = 0xD0) or with the “washer and dryer cycle setting 2” property (EPC = 0xD1) and the “drying cycle setting” property (EPC = 0xD2), and to acquire the current setting. Three rotation speed setting modes shall be available: “absolute setting,” “automatic setting” and “relative setting” (relative to the automatic setting). When the actual piece of equipment cannot operate at the speed specified with this property, the rotation speed to be used shall be implementation-dependent.

<Absolute setting>

It must be possible to specify the rotation speed in the 0x0000 to 0x0FFF (0 to 4095 r/min.) range and acquire the setting.

<Automatic setting; relative setting relative to the automatic setting>

0xFFFF shall be used for the “automatic setting” mode.

In relative setting in the positive direction, it must be possible to specify the rotation speed in the 0xA000 to 0xA7FF (1 to 2048 r/min.) range. In relative setting in the negative direction, it must be possible to specify the rotation speed in the 0xC000 to 0xC7FF (1 to 2048 r/min.) range.

(12) “Degree of drying” setting

“Degree of drying” setting property specifies, by selecting a level from among the predefined levels, the degree of drying for the washer and dryer cycle option(s) specified with the “washer and dryer cycle setting 1” property (EPC = 0xD0) or with the “washer and dryer cycle setting 2” property (EPC = 0xD1) and the “drying cycle setting” property (EPC = 0xD2), and to acquire the current setting. Three drying level setting modes shall be available: “absolute setting,” “automatic setting” and “relative setting” (relative to the automatic setting). When the actual piece of equipment cannot achieve the level specified with this property, the drying level to be used shall be implementation-dependent.

<Absolute setting>

It must be possible to specify the degree of drying by selecting a level from among 16 levels in the 0x31 to 0x40 (lowest to highest) range and acquire the setting.

<Automatic setting; relative setting relative to the automatic setting>

0xFF shall be used for the “automatic setting” mode.

In relative setting in the positive direction, it must be possible to specify the degree of drying by selecting a level from among 8 levels (Level 1 to Level 8) in the 0xA0

to 0xA7 range. In relative setting in the negative direction, it must be possible to specify the degree of drying by selecting a level from among 8 levels (Level 1 to Level 8) in the 0xC0 to 0xC7 range.

(13) Remaining washing time

Acquires the remaining washing time in the “hour (0x00-0xFE (0-254)): minute (0x00-0x3B (0-59))” format. The higher- and lower-order bytes shall be used for the “hour” and “minute” values, respectively. When the remaining time cannot be displayed because it is unknown, this property shall be set to “0xFF : 0xFF.”

(14) Remaining drying time

Acquires the remaining drying time in the “hour (0x00-0xFE (0-254)): minute (0x00-0x3B (0-59))” format. The higher- and lower-order bytes shall be used for the “hour” and “minute” values, respectively. When the remaining time cannot be displayed because it is unknown, this property shall be set to “0xFF : 0xFF.”

(15) Elapsed time on the ON timer

When the “ON timer reservation setting” property contains the value for “reservation ON,” this property is used to acquire the time elapsed on the ON timer after the ON timer is activated. The data format shall be “hour (0x00 to 0xFF (0 to 255)): minute (0x00 to 0x3B (0 to 59)).”

(16) Presoaking time setting

Presoaking time setting property specifies the duration of the presoaking process for the washer and dryer cycle option(s) specified with the “washer and dryer cycle setting 1” property (EPC = 0xD0) or by the “washer and dryer cycle setting 2” property (EPC = 0xD1) and the “drying cycle setting” property (EPC = 0xD2), and to acquire the current setting. Three presoaking time setting modes shall be available: “absolute setting,” “automatic setting” and “relative setting” (relative to the automatic setting). It is only required to implement the property values that are supported by the actual piece of equipment in which this class is implemented.

<Absolute setting>

The higher- and lower-order bytes shall be used for the “hour” and “minute” values, respectively.

It must be possible to specify the presoaking time in the “0x00: 0x00 to 0x17: 0x3B (0 minutes to 23 hours and 59 minutes)” range and acquire the setting. When the specified time is 0 minutes, the presoaking process will not be performed.

<Automatic setting; relative setting relative to the automatic setting>

“0xFF: 0xFF” shall be used for the “automatic setting” mode.

In relative setting in the positive direction, it must be possible to specify the presoaking time in the 0xA000 to 0xA03B (1 to 60 minutes) range. In relative setting in the negative direction, it must be possible to specify the presoaking time in the 0xC000 to 0xC03B (1 to 60 minutes) range.

(17) Current stage of washer and dryer cycle

Current stage of washer and dryer cycle property specifies the current stage of the washer and dryer cycle. It must be possible to identify the following stages using the values shown:

Washing: 0x41

Rinsing: 0x42

Spin drying: 0x43

Suspended: 0x44

Washing completed: 0x45

Washing/drying (without wrinkling minimization) completed: 0x51

Drying: 0x52

Wrinkling minimization: 0x53

Drying (with wrinkling minimization) completed: 0x54

Standing by to start: 0x61

1st rinsing: 0x71

2nd rinsing: 0x72

3rd rinsing: 0x73

4th rinsing: 0x74

5th rinsing: 0x75

6th rinsing: 0x76

7th rinsing: 0x77

8th rinsing: 0x78

1st spin drying: 0x81

2nd spin drying: 0x82

3rd spin drying: 0x83

4th spin drying: 0x84

5th spin drying: 0x85

6th spin drying: 0x86

7th spin drying: 0x87

8th spin drying: 0x88

Preheat spin drying: 0x91

In cases where it is possible to specify the number of times to repeat the rinsing process (i.e. 1st rinsing, 2nd rinsing, ...), values between 0x71 and 0x78 must be used. Otherwise, 0x42 shall be used. In cases where it is possible to specify the number of times to repeat the spin drying process (i.e. 1st spin drying, 2nd spin drying, ...), values between 0x81 and 0x88 must be used. Otherwise, 0x43 shall be used. In cases where a spin drying process is available in which warm air blows on the laundry while it is being dried, 0x91 shall be used for that spin drying process. The “standing by to start” stage shall include the “ON timer reservation ON” state. The relationship between the property values of this property (Get) and the property values of the “washer and dryer setting” property (Get)(EPC = 0xB2) are as shown in the table below.

“Current stage of washer and dryer cycle” property	“Washer and dryer setting” property (EPC = 0xB2)
Other than below	0x41: Washer and dryer cycle in progress
0x44: Suspended	0x42: Washer and dryer cycle suspended
0x45: Washing completed 0x51: Washing completed/drying (without wrinkling minimization) completed 0x54: Drying (with wrinkling minimization) completed 0x61: Standing by to start	0x43: Washer and dryer cycle stopped
0xE0-EF: Maker original code	Current washing and drying operation status at the washing and drying transition state defined by the individual maker

(18) Water volume setting 1

Water volume setting 1 property specifies the water volume (in liters) for the washer and dryer cycle option(s) specified with the “washer and dryer cycle setting 1” property (EPC = 0xD0) or by the “washer and dryer cycle setting 2” property (EPC = 0xD1) and the “drying cycle setting” property (EPC = 0xD2), and to acquire the current setting. Three water volume setting modes shall be available: “absolute setting,” “automatic setting” and “relative setting” (relative to the automatic setting). When the actual piece of equipment cannot handle the water volume specified with this property, the water volume to be used shall be implementation-dependent.

<Absolute setting>

It must be possible to specify the water volume in the 0x00 to 0x7F (0 to 127 liters) range and acquire the setting.

<Automatic setting; relative setting relative to the automatic setting>

“0xFF” shall be used for the “automatic setting” mode.

In relative setting in the positive direction, it must be possible to specify the water volume in the 0xA0 to 0xBF (1 to 32 liters) range. In relative setting in the negative direction, it must be possible to specify the water volume in the 0xC0 to 0xDF (1 to 32 liters) range.

In cases where both the “water volume setting 1” and “water volume setting 2” properties are implemented, the property values shall be correlated.

(19) Water volume setting 2

Water volume setting 2 property specifies the water volume for the washer and dryer cycle option(s) specified with the “washer and dryer cycle setting 1” property (EPC = 0xD0) or by the “washer and dryer cycle setting 2” property (EPC = 0xD1) and the “drying cycle setting” property (EPC = 0xD2), and to acquire the current setting. Three water volume setting modes shall be available: “absolute setting,” “automatic setting” and “relative setting” (relative to the automatic setting). When the actual piece of equipment cannot handle the water volume specified with this property, the level to be used shall be implementation-dependent. It is only required to implement the property values that are supported by the actual piece of equipment in which this class is implemented.

<Absolute setting>

It must be possible to specify the water volume by selecting a level from among 16 levels in the 0x31 to 0x40 (lowest to highest) range and acquire the setting.

<Automatic setting; relative setting relative to the automatic setting>

0xFF shall be used for the “automatic setting” mode.

In relative setting in the positive direction, it must be possible to specify the water volume by selecting a level from among 8 levels (Level 1 to Level 8) in the 0xA0 to 0xA7 range. In relative setting in the negative direction, it must be possible to specify the water volume by selecting a level from among 8 levels (Level 1 to Level 8) in the 0xC0 to 0xC7 range.

In cases where both the “water volume setting 1” and “water volume setting 2” properties are implemented, the property values for the “water volume setting 2” property shall be correlated with the property values for the “water volume setting 1” property.

(20) Washing time setting

Washing time setting property specifies the duration of the washing process for the washer and dryer cycle option(s) specified with the “washer and dryer cycle setting 1” property (EPC = 0xD0) or by the “washer and dryer cycle setting 2” property

(EPC = 0xD1) and the “drying cycle setting” property (EPC = 0xD2), and to acquire the current setting. Three washing time setting modes shall be available: “absolute setting,” “automatic setting” and “relative setting” (relative to the automatic setting). It is only required to implement the property values that are supported by the actual piece of equipment in which this class is implemented.

<Absolute setting>

The higher- and lower-order bytes shall be used for the “hour” and “minute” values, respectively.

It must be possible to specify the washing time in the “0x00: 0x00 to 0x17: 0x3B (0 minutes to 23 hours and 59 minutes)” range and acquire the setting. When the specified time is 0 minutes, the washing process will not be performed.

<Automatic setting; relative setting relative to the automatic setting>

“0xFF: 0xFF” shall be used for the “automatic setting” mode.

In relative setting in the positive direction, it must be possible to specify the washing time in the 0xA000 to 0xA03B (1 to 60 minutes) range. In relative setting in the negative direction, it must be possible to specify the washing time in the 0xC000 to 0xC03B (1 to 60 minutes) range.

(21) Number of times of rinsing

Number of times of rinsing property specifies the number of times of rinsing for the washer and dryer cycle option(s) specified with the “washer and dryer cycle setting 1” property (EPC = 0xD0) or by the “washer and dryer cycle setting 2” property (EPC = 0xD1) and the “drying cycle setting” property (EPC = 0xD2), and to acquire the current setting. The number of times of rinsing shall be a number between 0 and 8. When 0 is selected, no rinsing will be performed. In cases where the number of times of rinsing is automatically determined by the actual piece of equipment, 0xFF shall be used as the property value. It is only required to implement the property values that are supported by the actual piece of equipment in which this class is implemented.

(22) Rinsing process setting

Rinsing process setting property specifies the rinsing process(es) to use for the washer and dryer cycle option(s) specified with the “washer and dryer cycle setting 1” property (EPC = 0xD0) or by the “washer and dryer cycle setting 2” property (EPC = 0xD1) and the “drying cycle setting” property (EPC = 0xD2), and to acquire the current setting. Four bits shall be used for each rinsing process as specified below. It is only required to implement the property values that correspond to the rinsing processes supported by the actual piece of equipment in which this class is

implemented.

- Bits 0 through Bit 3: 1st rinsing
- Bits 4 through Bit 7: 2nd rinsing
- Bits 8 through Bit 11: 3rd rinsing
- Bits 12 through Bit 15: 4th rinsing
- Bits 16 through Bit 19: 5th rinsing
- Bits 20 through Bit 23: 6th rinsing
- Bits 24 through Bit 27: 7th rinsing
- Bits 28 through Bit 31: 8th rinsing

Each set of bits shall contain one of the following values:

- 0000: No mode specified
- 0001: Rinsing without additional supply of water from the tap
- 0010: Rinsing with additional supply of water from the tap
- 0011: Shower rinsing

The MSB of the first byte shall be Bit 31 and the LSB of the fourth byte shall be Bit 0.

(23) Spin drying time setting

Spin drying time setting property specifies the duration of the spin drying process for the washer and dryer cycle option(s) specified with the “washer and dryer cycle setting 1” property (EPC = 0xD0) or by the “washer and dryer cycle setting 2” property (EPC = 0xD1) and the “drying cycle setting” property (EPC = 0xD2), and to acquire the current setting. Three spin drying time setting modes shall be available: “absolute setting,” “automatic setting” and “relative setting” (relative to the automatic setting). It is only required to implement the property values that are supported by the actual piece of equipment in which this class is implemented.

<Absolute setting>

It must be possible to specify the spin drying time in the 0x00 to 0x3B (0 to 59 minutes) range and acquire the setting.

<Automatic setting; relative setting relative to the automatic setting>

“0xFF” shall be used for the “automatic setting” mode.

In relative setting in the positive direction, it must be possible to specify the spin drying time in the 0xA0 to 0xBF (1 to 32 minutes) range. In relative setting in the negative direction, it must be possible to specify the spin drying time in the 0xC0 to 0xDF (1 to 32 minutes) range.

(24) Drying time setting

Drying time setting property specifies the duration of the drying process for the washer and dryer cycle option(s) specified with the “washer and dryer cycle setting 1” property (EPC = 0xD0) or by the “washer and dryer cycle setting 2” property (EPC = 0xD1) and the “drying cycle setting” property (EPC = 0xD2), and to acquire the current setting. Three drying time setting modes shall be available: “absolute setting,” “automatic setting” and “relative setting” (relative to the automatic setting). It is only required to implement the property values that are supported by the actual piece of equipment in which this class is implemented.

<Absolute setting>

The higher- and lower-order bytes shall be used for the “hour” and “minute” values, respectively.

It must be possible to specify the drying time in the “0x00: 0x00 to 0x17: 0x3B (0 minutes to 23 hours and 59 minutes)” range and acquire the setting. When the specified drying time is 0 minutes, the drying process will not be performed.

<Automatic setting; relative setting relative to the automatic setting>

“0xFF: 0xFF” shall be used for the “automatic setting” mode.

In relative setting in the positive direction, it must be possible to specify the drying time in the 0xA000 to 0xA03B (1 to 60 minutes) range. In relative setting in the negative direction, it must be possible to specify the drying time in the 0xC000 to 0xC03B (1 to 60 minutes) range.

(25) Warm water setting

Warm water setting property specifies whether to use warm water in the washing process for the washer and dryer cycle option(s) specified with the “washer and dryer cycle setting 1” property (EPC = 0xD0) or by the “washer and dryer cycle setting 2” property (EPC = 0xD1) and the “drying cycle setting” property (EPC = 0xD2) or specify/change the temperature of the warm water (in °C) in cases where it is specified to use warm water, and to acquire the current setting. The warm water temperature shall be between 0 and 100°C. When the value is 0xFE, it shall mean that warm water is not used. When the value is 0xFF, it shall mean that the warm water temperature is automatically set. When the actual piece of equipment cannot achieve the temperature specified with this property, the warm water temperature to be used shall be implementation-dependent.

(26) Bathtub water recycle setting

Bathtub water recycle setting property specifies whether to use used bathtub water

for the washer and dryer cycle option(s) specified with the “washer and dryer cycle setting 1” property (EPC = 0xD0) or by the “washer and dryer cycle setting 2” property (EPC = 0xD1) and the “drying cycle setting” property (EPC = 0xD2) or select/reselect the process(es) in which used bathtub water is to be used in cases where it is specified to use bathtub water, and to acquire the current setting.

The property values shall be as follows:

Bathtub water not used = 0x40

Use bathtub water for washing only = 0x41

Use bathtub water for rinsing only (excluding the final rinsing process) = 0x42

Use bathtub water for all rinsing processes = 0x43

Use bathtub water for washing + rinsing (excluding the final rinsing process) = 0x44

Use bathtub water for washing + all rinsing processes = 0x45

(27) Wrinkling minimization setting

Wrinkling minimization setting property specifies whether or not to use the wrinkling minimization function after completion of the drying process for the washer and dryer cycle option(s) specified with the “washer and dryer cycle setting 1” property (EPC = 0xD0) or by the “washer and dryer cycle setting 2” property (EPC = 0xD1) and the “drying cycle setting” property (EPC = 0xD2), and to change or acquire the current setting. 0x41 shall be used when the wrinkling minimization function is to be used and 0x42 shall be used when the wrinkling minimization function is not to be used.

(28) Time remaining to complete washer and dryer cycle

Time remaining to complete washer and dryer cycle property specifies the time remaining to complete the current washer and dryer cycle in the “hour (0x00 to 0xFE (0 to 254)): minute (0x00 to 0x3B (0 to 59))” format. The higher- and lower-order bytes shall be used for the “hour” and “minute” values, respectively. When the time remaining to complete the washer and dryer cycle is unknown and cannot be displayed, “0xFF: 0xFF” shall be used.

(29) Door/cover lock setting

Door/cover lock setting property specifies the state of the door/cover during operation (i.e. locked or unlocked) and to acquire the current setting. 0x41 and 0x42 shall be used for the “locked” and “unlocked” states, respectively.

(30) Washer and dryer cycle

Washer and dryer cycle property specifies the current washer and dryer cycle setting

that has been specified with the “washer and dryer cycle setting 1” property (EPC = 0xD0) or by the “washer and dryer cycle setting 2” property (EPC = 0xD1) and the “drying cycle setting” property (EPC = 0xD2) and to which the settings specified with the following properties have been applied:

- Presoaking time setting (EPC = 0xE1)
- Water volume setting 1 (EPC = 0xE3)
- Water volume setting 2 (EPC = 0xE4)
- Washing time setting (EPC = 0xE5)
- “Number of times of rinsing” setting (EPC = 0xE6)
- Rinsing process setting (EPC = 0xE7)
- Spin drying time setting (EPC = 0xE8)
- Drying time setting (EPC = 0xE9)
- Warm water setting (EPC = 0xEA)
- Bathtub water recycle setting (EPC = 0xEB)
- Wrinkling minimization setting (EPC = 0xEC)
- Water flow rate setting (EPC = 0xD6)
- “Rotation speed for spin drying” setting (EPC = 0xD7)
- “Degree of drying” setting (EPC = 0xD8)

The first and second bytes comprise a bitmap list of the properties whose values may be obtained when applicable. When the value contained in a bit is “1,” it shall mean that the setting specified with the property represented by that bit is effective and can be obtained with this property.

- | | |
|---|--|
| Bit 0: Presoaking | Bit 1: Washing time setting |
| Bit 2: “Number of times of rinsing” setting | Bit 3: Rinsing process setting |
| Bit 4: Spin drying time setting | Bit 5: Drying time setting |
| Bit 6: Warm water setting | Bit 7: Water volume setting 1 |
| Bit 8: Water volume setting 2 | Bit 9: Bathtub water recycle setting |
| Bit 10: Water flow rate setting | Bit 11: “Rotation speed for spin drying” setting |
| Bit 12: “Degree of drying” setting | Bit 13: Presoaking time setting |
| Bit 14: Wrinkling minimization setting | Bit 15: Reserved for future use. |

The third byte indicates whether or not to use the presoaking process. 0x41 shall mean that the presoaking process is used and 0x42 shall mean that the presoaking process is not used. When the value contained in the third byte is 0x41 and Bit 13 of the set of the first and second bytes contains “1” (= effective), the 22nd and 23rd bytes must contain an appropriate value.

The fourth and fifth bytes indicate the washing time specified. This value shall be identical to the value of the “washing time setting” property.

The sixth byte indicates the number of times of rinsing specified. This value shall be identical to the value of the “number of times of rinsing’ setting” property.

The seventh through tenth bytes indicate the rinsing process(es) specified. This value shall be identical to the value of the “rinsing process setting” property.

The eleventh byte indicates the spin drying time specified. This value shall be identical to the value of the “spin drying time setting” property.

The twelfth and thirteenth bytes indicate the drying time specified. This value shall be identical to the value of the “drying time setting” property.

The fourteenth byte indicates the warm water setting specified. This value shall be identical to the value of the “warm water setting” property.

The fifteenth byte indicates the water volume specified with the “water volume setting 1” property. This value shall be identical to the value of the “water volume setting 1” property.

The sixteenth byte indicates the water volume specified with the “water volume setting 2” property. This value shall be identical to the value of the “water volume setting 2” property.

The seventeenth byte indicates the bathtub water recycle setting specified. This value shall be identical to the value of the “bathtub water recycle setting” property.

The eighteenth byte indicates the water flow rate specified. This value shall be identical to the value of the “water flow rate setting” property.

The nineteenth and twentieth bytes indicate the rotation speed specified for spin drying. This value shall be identical to the value of the “rotation speed for spin drying’ setting” property.

The twenty-first byte indicates the degree of drying specified. This value shall be identical to the value of the “degree of drying’ setting” property.

The twenty-second and twenty-third bytes indicate the presoaking time specified. This value shall be identical to the value of the “presoaking time setting” property. When the presoaking time setting is effective and Bit 0 of the set of the first and second bytes contains “1” (effective), the third byte must contain the appropriate value.

The twenty-fourth byte indicates the wrinkling minimization setting specified. This value shall be identical to the value of the “wrinkling minimization setting” property.

(31) ON timer reservation setting

ON timer reservation setting property specifies whether or not to use the ON timer-based reservation function (i.e. reservation ON or reservation OFF), and to acquire the current setting. The property value shall be 0x41(reservation ON) or

0x41(reservation OFF).This property is used in combination with the “ON timer setting” or “relative time-based ON timer setting” property.

(32) ON timer setting

When the value of the ““ON timer reservation’ setting” property is “reservation ON”, this property is used to specify the time when the value of the “washer and dryer setting” property (EPC = 0xB2) will change to “start” (0x41) or the time when the value of the “current stage of washer and dryer cycle” property (EPC = 0xE2) will change to “washing completed” (0x45), “washing/drying (without wrinkling minimization) completed” (0x51) or “drying (with wrinkling minimization) completed” (0x54), in the “hour (0x00 to 0x17 (0 to 23)) : minute (0x00 to 0x3B (0 to 59))” format, and to acquire the current setting. The higher- and lower-order bytes shall be used for the “hour” and “minute” values, respectively.

(33) Relative time-based ON timer setting

When the value of the ““ON timer reservation’ setting” property is “reservation ON”, this property is used to specify the time when the value of the “washer and dryer setting” property (EPC = 0xB2) will change to “start” (0x41) or the time when the value of the “current stage of washer and dryer cycle” property (EPC = 0xE2) will change to “washing completed” (0x45), “washing/drying (without wrinkling minimization) completed” (0x51) or “drying (with wrinkling minimization) completed” (0x54), in terms of a relative time relative to the current time, and to acquire the current setting. The “hour (0x00 to 0xFF (0 to 255)) : minute (0x00 to 0x3B (0 to 59))” format shall be used.

3. 5 Health-related Device Class Group

This section specifies detailed codes and properties for each ECHONET object belonging to the health-related device class group (class group specification code X1 = 0x04). Table 3-5 shows a list of classes specified in detail in this section. In the requirements of classes, “Mandatory” means that the device mounting each class must mount a combination of its property and service.

Table 3-5 List of Objects of Health-related Device Class Group

Group code	Class code	Class name	Detailed requirements	Remark
0x04	0x00	Reserved for future use		
	0x01	Weighing machine	○	
	0x02	Clinical thermometer		
	0x03	Blood pressure meter		
	0x04	Blood sugar meter		
	0x05	Body fat meter		
	0x06-0xFF	Reserved for future use.		

Note: ○ indicates a detail is explained including a property structure in APPENDIX.

3. 5. 1 Requirements for weighing machine class

Class group code : 0x04

Class code : 0x01

Instance code : 0x01–0x7F (0x00: All-instance specification code)

Property name	EPC	Contents of property	Data type	Data size	Unit	Access rule	Mandatory	Announcement at status change	Remark
		Value range (decimal notation)							
Operation status	0x80	This property indicates the ON/OFF status of the weighing machine operation	unsigned short	1 byte	—	Set		○	
		ON=0x30, OFF=0x31							
Measured value of body weight	0xE0	This property indicates measured value of body weight in units of 0.1 kg.	unsigned short	2 bytes	0.1 kg	Get			
		0x0000–0xFFFD (0–6553.3kg)							
Measured value of body fat	0xE1	This property indicates measured value of body fat in units of 0.1%.	unsigned short	2 bytes	0.1%	Get			
		0x0000–0x03E8 (0–100.0%)							

Note: In the “Announcement at status change” column, ○ denotes mandatory processing when the property is implemented.

- (1) Operation status (inherited from the device object super class property)
 This property indicates the ON/OFF status of the weighing machine operation.
- (2) Measured value of body weight
 This property indicates the measured body weight in units of 0.1 kg.
- (3) Measured value of body fat
 This property indicates the measured value of body fat in units of 0.1%.

3. 6 Management/Operation-related Device Class Group

This section specifies detailed codes and properties for each ECHONET object belonging to the management/operation-related device class group (class group specification code X1 = 0x05). Table 3-6 shows a list of classes specified in detail in this section. In the requirements of classes, “Mandatory” means that the device mounting each class must mount a combination of its property and service.

Table 3-6 List of Objects of Management/Operation-related Device Class Group

Class group code	Class code	Class name	Announcement at status change	Remark
0x05	0x00 to 0xFB	For future reserved		
	0xFC	Secure communication shared key setup node	●	
	0xFD	Switch (supporting JEM-A/HA terminals)	○	
	0xFE	Portable (mobile) terminal.		
	0xFF	Controller		

Note: ● indicates a detail is explained including a property structure in Part 2 of the ECHONET Specification.

3. 6. 1 Requirements for switch class (supporting JEM-A/HA terminals)

Class group code : 0x05

Class code : 0xFD

Instance code : 0x01- 0x7F (0x00: All-instance specification code)

Property name	EPC	Contents of property	Data type	Data size	Unit	Access rule	Mandatory	Announcement at status change	Remark
		Value range (decimal notation)							
Operation status	0x80	This property indicates the ON/OFF status.	unsigned char	1 byte	—	Set	○	○	
		ON=0x30, OFF=0x31				Get	○		
Connected device	0xE0	Name of the device to connect to	unsigned char	12 bytes	—	Set			
		Stores the name of the type of the device.				Get			

Note: In the “Announcement at status change” column, ○ denotes mandatory processing when the property is implemented.

(1) Operation status (a property inherited from the device object super class)

This property indicates whether the functions specific to this class are operating (ON) or not (OFF). In the case of Get, the status of the M signal of the HA terminal shall be reflected. In the case of Set, the set value shall be compared with the value of the M signal of the HA terminal, and if they are different, the prescribed pulse shall be output (C signal of the HA terminal).

(2) Connected device

Stores the name of the type of the device to connect to in the form of an ASCII code. This value shall be stored in a non-volatile memory.
 (Refer to the explanation about the “Product code” property.)

3. 7 Audiovisual-related Device Class Group

This section specifies the requirements, including the code values and property specifications, for each of the device objects which are ECHONET objects and belong to the Audiovisual-related Device Class Group (class group designation code X1 = 0x06).

Table 3-7 lists the classes covered by this section. The detailed requirements for each of the classes are specified in the respective subsection of this section. Each property specified as a required or conditionally required property with the ○ mark or a conditionally required property symbol in the “Mandatory” column of the applicable row of the property table is a property that must be implemented in combination with the applicable service(s) whenever the class to which that property belongs is implemented in a device.

Table 3-7 List of Objects of the Audiovisual-related Device Class Group

Class group code	Class code	Class name	Detailed requirements	Remark
0x06	0x00	For future reserved		
	0x01	Display	○	
	0x02	Television	○	
	0x03-0xFF	For future reserved		

Note: ○ indicates a detail is explained including a property structure in APPENDIX.

3. 7. 1 Requirements for display class

Class group code : 0x06

Class code : 0x01

These requirements for the display class shall apply to character display function-related sections (display sections, display control sections, display data buffering sections, etc.) of display devices which belong to the Audiovisual-related Device Class Group, and to character display function-related sections of devices equipped with a display function which belong to other class groups. New properties for character display functions (such as properties relating to characteristics of characters used in character displays (font, size, color, etc.), methods to display characters on displays and display locations) will be added in the future as necessary.

Specifically, these requirements for the display class shall apply to displays dedicated to displaying characters and to character display sections (LCD display sections) of devices of all classes.

Property name	EPC	Contents of property	Data type	Data size	Unit	Access rule	Mandatory	Announcement at status change	Remark
		Value range (decimal notation)							
Operation status	0x80	This property indicates the ON/OFF status of the weighing machine operation	unsigned char	1 byte	—	Set	Ⓢ	○	
		ON=0x30, OFF=0x31				Get	○		
Display control setting	0xB0	Sets the status as to whether the displaying of characters is enabled or disabled and acquires the current setting.	unsigned char	1 byte	—	Set/ Get			
		Displaying enabled: 0x30 Displaying disabled: 0x31							
Character string setting acceptance status	0xB1	This property indicates whether or not the device is ready to accept the character string to present to the user.	unsigned char	1 byte	—	Get	○	○	
		Ready: 0x30 Busy: 0x31							
Supported character codes	0xB2	This property indicates, in a bit map format, the implemented character codes that can be used to present character strings.	unsigned char×2	2 bytes	—	Get	○		

		Bit 0 ANSI X3.4 Implemented: 1 Not implemented: 0 Bit 1 Shift-JIS Implemented: 1 Not implemented: 0 Bit 2 JIS Implemented: 1 Not implemented: 0 Bit 3 Japanese EUC Implemented: 1 Not implemented: 0 Bit 4 UCS-4 Implemented: 1 Not implemented: 0 Bit 5 UCS-2 Implemented: 1 Not implemented: 0 Bit 6 Latin-1 Implemented: 1 Not implemented: 0 Bit 7 UTF-8 Implemented: 1 Not implemented: 0 Bit 8 and succeeding bits: for future reserved 0							
Character string to present to the user	0xB3	Sets the character string to present to the user, the length of the character string and the character code to use to present the character string and acquires the stored setting. The highest-order byte shall indicate the byte sequence data length of the character string to present to the user and the second-highest-order byte shall indicate the character code to use. The second-highest-order byte shall be followed by a byte containing "0x00" (for future reserved), which shall be followed by a number of bytes, each assigned with one of the first and succeeding bytes, starting with the first byte, of the character string to present to the user. The lowest-order byte shall be assigned with the last byte of the character string to present to the user.	unsigned char× Max 247	Max 247 bytes	—	Set Get	○		

		First byte: Byte code sequence data length of the character string to present to the user converted to the hexadecimal format Second byte: Character code to use Third byte: for future reserved Fourth and succeeding bytes: Byte code sequence of the character string to present to the user (max. 244 bytes) Each of the character codes listed below shall be assigned with the indicated code value. ANSI X3.4=0x01 Shift -JIS=0x02 JIS =0x03 Japanese EUC=0x04 UCS-4 =0x05 UCS-2 =0x06 Latin -1=0x07 UTF-8=0x08 0x09 and succeeding values = for future reserved							
Length of character string accepted	0xB4	This property indicates the total number of bytes of the newest character string to present to the user which has been set and is being held.	unsigned char	2 byte	-	Get	○		
		First byte: 0x00 to 0xF4 Second byte: 0x00 (for future reserved)							

Note: In the “Announcement at status change” column, ○ denotes mandatory processing when the property is implemented.

(1) Operation status (inherited from the super class property)

Sets the ON/OFF status of the display and acquires the current setting. The values “0x30” and “0x31” shall be assigned to the ON and OFF states, respectively. In the case where an “energy service” is to be supported, the implementation of the SET function for this property is mandatory.

(2) Display control setting

A SET on this property sets the status of this class as to whether the displaying of characters is enabled or disabled. A GET on this property acquires the current setting. The values “0x30” and “0x31” shall be assigned to the “Displaying enabled” and “Displaying disabled” states, respectively. Because this property is a function to just switch between the “Displaying enabled” and “Displaying disabled” states, SETs on the “Character string to present to the user” property must be effective even when the “Display control setting” property value is “0x31” (Displaying disabled) as long as the “Character string setting acceptance status” property value is “0x30.”

(3) Character string setting acceptance status

A GET on this property shows the status as to whether this class is ready to accept the “Character string to present to the user” property settings. The values “0x30” and “0x31” shall be assigned to the “Ready” state (i.e. the state in which the settings can be accepted) and “Busy” state (i.e. the state in which the settings cannot be accepted), respectively.

(4) Supported character codes

A SET on this property shows a bit map list of the implemented character codes (sets of coded characters) that can be used by this class to present character strings. The value “0” indicates that the code in question is not implemented, and the value “1” indicates that the code in question is implemented.

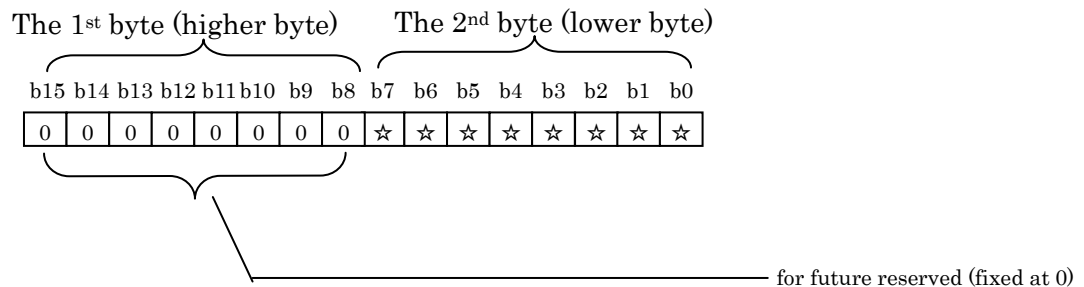

The relationship between the bits and codes is as follows:

- Bit 0 — ANSI X3.4: Implemented = 1 Not implemented = 0
- Bit 1 — Shift-JIS: Implemented = 1 Not implemented = 0
- Bit 2 — JIS: Implemented = 1 Not implemented = 0
- Bit 3 — Japanese EUC: Implemented = 1 Not implemented = 0
- Bit 4 — UCS-4: Implemented = 1 Not implemented = 0
- Bit 5 — UCS-2: Implemented = 1 Not implemented = 0
- Bit 6 — Latin-1: Implemented = 1 Not implemented = 0
- Bit 7 — UTF-8: Implemented = 1 Not implemented = 0
- Bits 8 to 15 — for future reserved (fixed at 0)

For the detailed specifications for the character codes, refer to the following standards:

- ANSI X3.4 : American National Standards Institute, "Coded character set -- 7-bit American national standard code for information interchange", ANSI X3.4-1986.(ASCII)
- Shift-JIS : JIS X 0208:1997 “7-bit and 8-bit double byte coded Kanji sets for information interchange”
- JIS : ISO/IEC 2022 :1994 Information technology -- Character code structure and extension techniques, ISO-2022-JP (JIS X 0208:1997)

- Japanese EUC : ISO/IEC 2022 :1994 Information technology -- Character code structure and extension techniques, ISO-2022-JP (JIS X 0208:1997)
- UCS-4 ,UCS-2 : ISO/IEC 10646-1:2000 Information technology -- Universal Multiple-Octet Coded Character Set (UCS) -- Part 1: Architecture and Basic Multilingual Plane.
- Latin-1 : ISO/IEC 8859-1:1998 Information technology -- 8-bit single-byte coded graphic character sets -- Part 1: Latin alphabet No. 1
- UTF-8 : RFC 3629 “UTF-8,a transformation format of ISO 10646”

(5) Character string to present to the user

A SET on this property sets the character string to present to the user of this class, the length of the character string and the character code to use to present the character string. SETs on this property must be effective when the “Character string setting acceptance status” property value is “0x30.”

The highest-order byte shall indicate the byte code sequence length of the character string to present to the user converted to the hexadecimal format and the second-highest-order byte shall indicate the character code to use to present the character string. The second-highest-order byte shall be followed by a byte (the third byte) containing “0x00” (for future reserved), which shall be followed by a number of bytes (the fourth and succeeding bytes), each assigned with one of the first and succeeding byte code characters, starting with the first byte code character, of the character string to present to the user. The lowest-order byte shall be assigned with the last byte code character of the character string to present to the user. The character string to present to the user may contain control codes. A GET on this property acquires “the byte code sequence length of the character string to present to the user converted to the hexadecimal format that has been set in this property through the SET function” (first byte), “the character code to use to present the character string to the user that has been set through the SET function” (second byte), the value “0x00” (for future reserved) (third byte) and “the byte code sequence for the character string to present to the user that has been successfully set” (fourth and succeeding bytes).

The character codes are represented as follows: ANSI X3.4 = 0x01, Shift-JIS = 0x02, JIS = 0x03, Japanese EUC = 0x04, UCS-4 = 0x05, UCS-2 = 0x06, Latin-1 = 0x07, UTF-8 = 0x08. This class shall use the character code specified by the character code setting of this property when handling the received character string to present to the user. This property shall be effective even when the value of the “Operation status” property (0x80) is OFF (0x31). The byte order for this property shall be as shown in the figure below.

The 1st byte (The most significant)	The 2nd byte	The 3rd byte	The 4th byte	The Nth byte (The least significant)
Bytes from the 4th to the Nth byte (in case of SET)	Transmission Character array setting character code	0x00 (for future reserved)	Transmission character array code The first byte	Transmission character array code The last byte

Below are examples showing how this property works.

When the character string “ECHONET” is set using the SET function with ANSI X3.4 specified as the character code to use:

- The content of the property will be “0x0701004543484F4E4554.”

Examples of the result of a subsequent GET:

- Normal success: 0x0701004543484F4E4554
- Failure: 0x0701004543484F4E (The writing of the last 2 bytes failed because of a memory shortage, etc.)
- Success: 0x04020031323334 (Another node has set “0x04020031323334” using the SET function after the first SET.)

(6) Length of character string accepted

A GET on this property acquires the data length of the newest character string to present to the user which is being held by the “Character string to present to the user” property of this class as the first byte. This is not necessarily the same as the first byte acquired by a GET on the “Character string to present to the user” property (byte value of the byte code sequence length). The content of this property shall be updated in conjunction with the “Character string to present to the user” property. The second byte of this property shall be “0x00” (for future reserved). This property shall be effective even when the value of the target “Operation status” property for writing (0x80) is OFF (0x31).

3. 7. 2 Requirements for television class

Class group code : 0x06

Class code : 0x02

These requirements for the television class shall apply to televisions in general.

Functions unique to this class will be added in the future as necessary.

Property name	EPC	Contents of property	Data type	Data size	Unit	Access rule	Mandatory	Announcement at status change	Remark
		Value range (decimal notation)							
Operation status	0x80	Refer to the section on the requirements for the display class (class group code = 0x06, class code = 0x01).	unsigned char	1 byte	—	Set	Ⓔ	○	
						Get	○		
Display control setting	0xB0	Refer to the section on the requirements for the display class (class group code = 0x06, class code = 0x01).	unsigned char	1 byte	—	Set/Get			
Character string setting acceptance status	0xB1	Refer to the section on the requirements for the display class (class group code = 0x06, class code = 0x01).	unsigned char	1 byte	—	Get	Ⓔ Ⓢ	○	
Supported character codes	0xB2	Refer to the section on the requirements for the display class (class group code = 0x06, class code = 0x01).	unsigned char× 2	2 bytes	—	Get	Ⓔ Ⓢ		
Character string to present to the user	0xB3	Refer to the section on the requirements for the display class (class group code = 0x06, class code = 0x01).	unsigned char× Max 247	Max 247 bytes	—	Set	○		
						Get			
Length of character string accepted	0xB4	Refer to the section on the requirements for the display class (class group code = 0x06, class code = 0x01).	unsigned char	2 bytes	—	Get	Ⓔ Ⓢ		

Note: In the “Announcement at status change” column, ○ denotes mandatory processing when the property is implemented.

(1) Operation status (The super class property is inherited.)

Sets the ON/OFF status of the television and acquires the current operation status setting. The values “0x30” and “0x31” shall be assigned to the ON and OFF states, respectively. In the case where an “energy service” is to be supported, the implementation of the SET function for this property is mandatory.

(2) Display control setting

Refer to the section on the requirements for the display class (class group code = 0x06, class code = 0x01).

(3) Character string setting acceptance status

Refer to the section on the requirements for the display class (class group code = 0x06, class code = 0x01).

In the case where a “home amenity service” or a “security service” is to be supported, the implementation of this property is mandatory

(4) Supported character codes

Refer to the section on the requirements for the display class (class group code = 0x06, class code = 0x01).

In the case where a “home amenity service” or a “security service” is to be supported, the implementation of this property is mandatory.

(5) Character string to present to the user

Refer to the section on the requirements for the display class (class group code = 0x06, class code = 0x01).

The implementation of the SET function for this property is mandatory.

(6) Length of character string accepted

Refer to the section on the requirements for the display class (class group code = 0x06, class code = 0x01).

In the case where a “home amenity service” or a “security service” is to be supported, the implementation of this property is mandatory.

Annex 1 Property Map Description Format

When the number of properties is 16 or less, Description Format 1 described below shall be used. When the number of properties is more than 16, Description Format 2 described below shall be used.

Description Format 1

First byte : Number of properties (binary notation)

Second and succeeding bytes : The property codes (1-byte codes) shall be listed as they are.

Here is an example of property map description format (1) for an ECHONET node of the switch class (0x05FD).

NO	PROPERTY NAME	EPC
1	Operation status	0x80
2	Installation location	0x81
3	Standard version information	0x82
4	Identification number	0x83
5	Fault status	0x88
6	Manufacturer code	0x8A
7	Status change announcement property map	0x9D
8	Set property map	0x9E
9	Get property map	0x9F
10	Connected device	0xE0

The first byte is 0x0A because the number of properties is 10. For the second and later bytes, the above EPCs are enumerated as 0x0A, 0x80, 0x81, 0x82, 0x83, 0x88, 0x8A, 0x9D, 0x9E, 0x9F, and 0xE0.

Description Format 2

First byte : Number of properties (binary notation)

Second to 17th bytes : "1" shall be set in the bits representing the codes for the properties that exist in the 16-byte table shown below, and the values shall be listed in the order of byte number from the second byte.

	Bit 7	Bit 6	Bit 5	Bit 4	Bit 3	Bit 2	Bit 1	Bit 0
Second byte	F0	E0	D0	C0	B0	A0	90	80
Third byte	F1	E1	D1	C1	B1	A1	91	81

Fourth byte	F2	E2	D2	C2	B2	A2	92	82
Fifth byte	F3	E3	D3	C3	B3	A3	93	83
Sixth byte	F4	E4	D4	C4	B4	A4	94	84
Seventh byte	F5	E5	D5	C5	B5	A5	95	85
Eighth byte	F6	E6	D6	C6	B6	A6	96	86
Ninth byte	F7	E7	D7	C7	B7	A7	97	87
Tenth byte	F8	E8	D8	C8	B8	A8	98	88
Eleventh byte	F9	E9	D9	C9	B9	A9	99	89
Twelfth byte	FA	EA	DA	CA	BA	AA	9A	8A
Thirteenth byte	FB	EB	DB	CB	BB	AB	9B	8B
Fourteenth byte	FC	EC	DC	CC	BC	AC	9C	8C
Fifteenth byte	FD	ED	DD	CD	BD	AD	9D	8D
Sixteenth byte	FE	EE	DE	CE	BE	AE	9E	8E
Seventeenth byte	FF	EF	DF	CF	BF	AF	9F	8F

Note) Bit value 0: the property does not exist; bit value 1: the property exists.

Following is an example of Description Format 2 for the property map. This example shows the case of an ECHONET node in which the “Home air conditioner” class (0x0130) is implemented.

NO	Property name	EPC	Corresponding property map bit
1	Operation status	0x80	Bit 0 of the second byte
2	Installation location	0x81	Bit 0 of the third byte
3	Standard version information	0x82	Bit 0 of the fourth byte
4	Identification number	0x83	Bit 0 of the fifth byte
5	Current limit setting	0x87	Bit 0 of the ninth byte
6	Fault status	0x88	Bit 0 of the tenth byte
7	Fault description	0x89	Bit 0 of the eleventh byte
8	Manufacturer code	0x8A	Bit 0 of the twelfth byte
9	Business facility code	0x8B	Bit 0 of the thirteenth byte
10	Product code	0x8C	Bit 0 of the fourteenth byte
11	Production number	0x8D	Bit 0 of the fifteenth byte
12	Production date	0x8E	Bit 0 of the sixteenth byte
13	Power-saving operation setting	0x8F	Bit 0 of the seventeenth byte

14	ON timer reservation setting	0x90	Bit 1 of the second byte
15	Cumulative operating time	0x9A	Bit 1 of the twelfth byte
16	SetM property map	0x9B	Bit 1 of the thirteenth byte
17	GetM property map	0x9C	Bit 1 of the fourteenth byte
18	Status change announcement property map	0x9D	Bit 1 of the fifteenth byte
19	Set property map	0x9E	Bit 1 of the sixteenth byte
20	Get property map	0x9F	Bit 1 of the seventeenth byte
21	Operation mode setting	0xB0	Bit 3 of the second byte
22	Temperature setting	0xB3	Bit 3 of the fifth byte

When the properties listed above are published in the ECHONET node:

The first byte is 0x16 because the number of properties is 22. The second byte is 0x0B (=b'00001011') because the 0x80, 0x90 and 0xB0 properties are published and the corresponding bits are "Bit 0," "Bit 1" and "Bit3." The third, fourth, ninth, tenth and eleventh bytes are 0x01 because the 0x81, 0x82, 0x87, 0x88 and 0x89 properties are published and the corresponding bit is "Bit 0." The fifth byte is 0x09 (=b'00001001') because the 0x83 and 0xB3 properties are published and the corresponding bits are "Bit 0" and "Bit 3." The twelfth to seventeenth bytes are 0x03 (=b'00000011') because the 0x8A, 0x9A, 0x8B, 0x9B, 0x8C, 0x9C, 0x8D, 0x9D, 0x8E, 0x9E, 0x8F and 0x9F properties are published and the corresponding bits are "Bit 0" and "Bit 1."

Therefore, the property map description format for this case is:

"0x16, 0x0B, 0x01, 0x01, 0x09, 0x00, 0x00, 0x00, 0x01, 0x01, 0x01, 0x03, 0x03, 0x03, 0x03, 0x03, 0x03, 0x03"